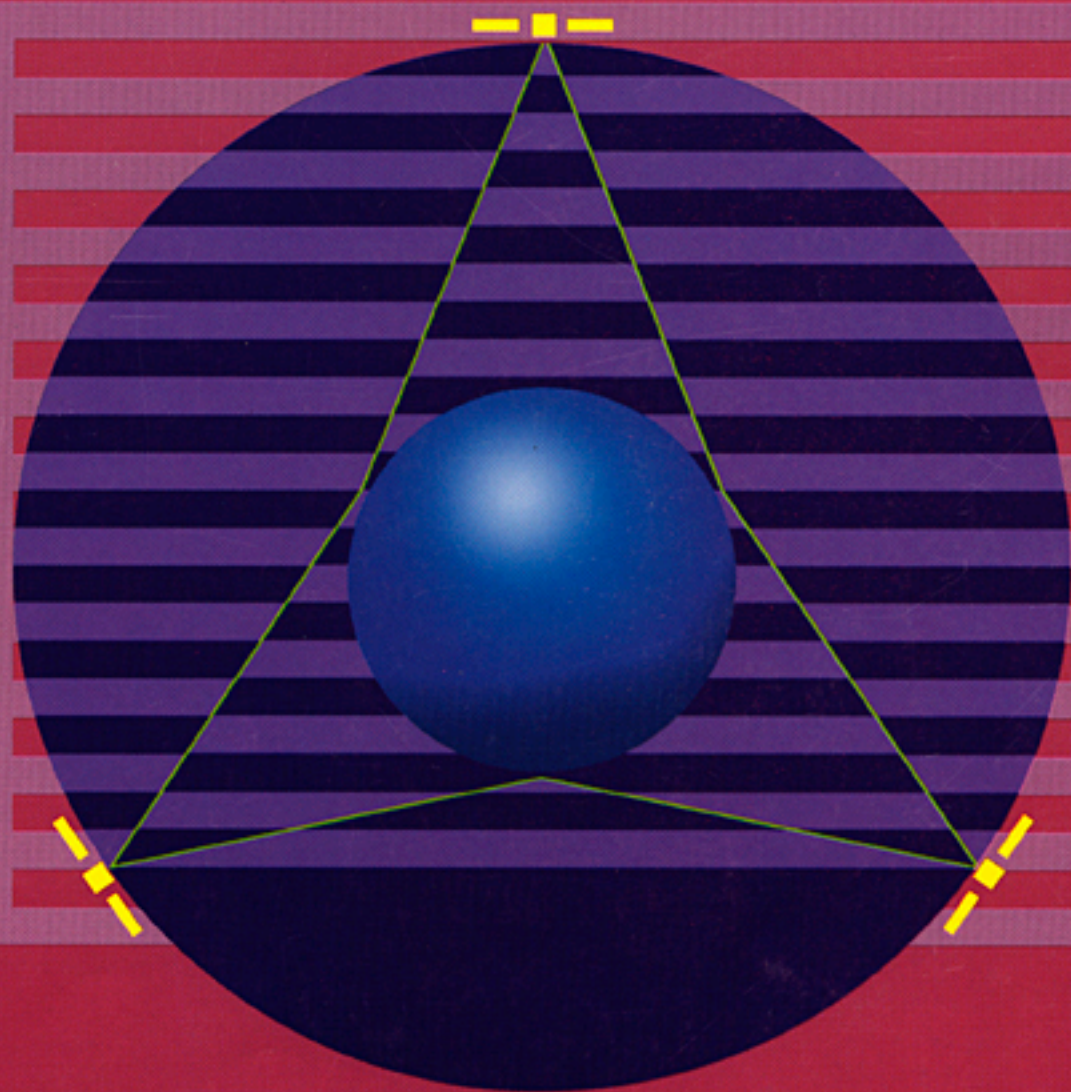


## Satellite communications



# Contents

Guest editorial <i>Odd Gutteberg</i>	<b>3</b>	Terminals for mobile satellite communications <i>Jens Andenæs</i>	<b>49</b>
Elements of satellite technology and communication <i>Odd Gutteberg</i>	<b>4</b>	Future systems for mobile satellite communications <i>Per Hovstad and Odd Gutteberg</i>	<b>54</b>
Satellite communications standardisation in Europe <i>Gunnar Stette</i>	<b>22</b>	Effects of atmosphere on earth-space radio propagation <i>Odd Gutteberg</i>	<b>63</b>
A review of Norwegian space activities <i>Georg Rosenberg</i>	<b>26</b>	The use of millimetre waves in satellite communications <i>Tord Fredriksen</i>	<b>71</b>
TSAT - a low-cost satellite communication network <i>Terje Pettersen and Petter Chr Amundsen</i>	<b>31</b>	The effect of interference for an OBP system utilising the geostationary orbit <i>Per Hovstad</i>	<b>75</b>
Very Small Aperture Terminal (VSAT) systems - basic principles and design <i>Liv Oddrun Voll and Gunn Kristin Klungsøyr</i>	<b>39</b>	Earth station antenna technology <i>Arnfinn Nyseth and Svein A Skyttemyr</i>	<b>85</b>
Fleet management using INMARSAT-C and GPS - a Norwegian pilot project <i>Arvid Bertheau Johannessen</i>	<b>46</b>		

# Guest editorial

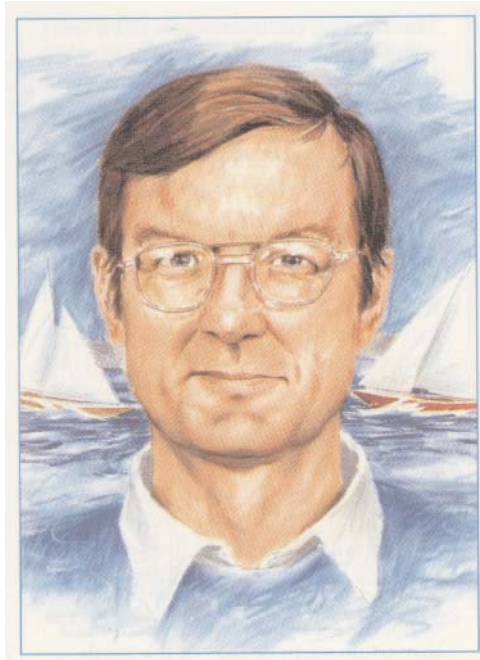
BY ODD GUTTEBERG

Developing the Norwegian telecommunication network has always been a challenging effort. This is due to this country's special topography and its scattered population. Furthermore, it has been difficult to establish reliable communications with the merchant fleet, oil rigs, and an important Norwegian outpost - the Arctic islands of Svalbard (Spitzbergen).

In the early sixties, it became evident that communications via satellites opened up new opportunities for surmounting these difficulties. Norwegian Telecom understood the possibilities, and as the first country in Europe, Norway established in 1976 a domestic satellite communication system. This system, called NORSAT-A, utilised leased transponder capacity on the geostationary INTELSAT-IV satellite for communication between the Norwegian mainland and the oil rigs in the North Sea. In 1979 Svalbard was connected to this system. The earth station at Svalbard was the first commercial earth station world-wide, operating with an elevation angle less than 3 degrees.

The success with the NORSAT-A system has been followed up by a meshed network, the NORSAT-B system. This system utilises Very Small Aperture Terminals (VSAT) for business communications.

As a large shipping nation, Norway caught an early interest in using satellites for maritime communications. In the seventies Norwegian Telecom was one of the driving forces behind the establishment of the International Maritime Satellite Organisation (INMARSAT), and Norway is at present the third largest shareholder. The first European coastal earth station in the INMARSAT system was built in southern Norway, and put into service in 1982.



The Norwegian telecommunications industry has been very active since satellite transmission was introduced in Norway. Among other things they are manufacturing the earth stations in NORSAT-B, and coastal earth stations and mobile terminals for the different INMARSAT standards. Norwegian industry has also developed a new data collection satellite system, called TSAT (Telemetry via SATellite).

The last addition to the "family tree" is satellite broadcasting. This application is especially attractive for a sparsely populated country like Norway. A major step was taken when the Norwegian Telecom bought the powerful TV satellite "Marco Polo 2" from Britain in 1992. The satellite was renamed "Thor" and moved to the position

1 degree west in the geostationary orbit. The purchase of this satellite represents a significant change in Norwegian space activity. The Norwegian Telecom has now moved from being a satellite user to a satellite owner and operator - with all the challenging tasks this implies.

As the satellite technology improves, the earth terminal becomes smaller and cheaper, as we have seen in the VSAT systems. However, the major challenge for the satellite community is now to provide a global mobile telephone system with hand-held terminals. This will necessitate studies of new concepts such as satellites in low-earth orbits, inter-satellite links, multibeam antennas, on-board processing and possibly use of higher frequency bands.

*Odd Gutteberg*

# Elements of satellite technology and communication

BY ODD GUTTEBERG

621.396.946

## 1 Introduction and overview

More than 35 years ago, on 4 October 1957, the world's first artificial satellite was launched by the Soviet Union. The satellite, which became known as Sputnik-1, opened up a new era of practical use of the outer space. The satellite's weight was 84 kg and it circled 1400 times around the earth before burning up in the atmosphere after 93 days. The launch of Sputnik-1 was followed by the United States' Explorer-1 in January 1958. Even though these satellites were primarily not intended for communications, they demonstrated that this was technically and economically feasible.

The use of artificial satellites in earth orbits is now a well established and integrated part of the world's telecommunication network. The evolution of the satellite technology together with more powerful launchers have made the satellites suitable, not only for long distance communications, but also for national communications, television broadcasting and mobile services.

A satellite communication system is divided into two major parts, the earth segment and the space segment. The satellite and its control station form the space segment, while the earth segment comprises the traffic and traffic control stations, see figure 1.

The satellite control station (TT&C station) maintains the satellite in orbit. It keeps control of the satellite status (Telemetry), orbital information (Tracking), and performs orbital attitude manoeuvres and configures the communication system (Command).

The communication part of the satellite system is simply a radio system with only one relay station, the satellite. The signals are transmitted on a carrier frequency,  $f_A$ , from an earth station (traffic station), received in the satellite, amplified, shifted in frequency to  $f'_A$  and transmitted back to the receiving traffic station. The satellite transmits and receives on radio frequencies mainly in the microwave band, i.e. 3 - 30 GHz. On these frequencies it is feasible to use parabolic reflector antennas. Such antennas concentrate the radio signals in a small cone; thus it is possible to "illuminate" the whole earth or part of the earth, see figure 2. The illuminated part is called the coverage area, and most of the transmitted power from the satellite is concentrated in this area. The larger the transmitting satellite antenna is, the smaller the coverage area becomes.

The up-link signals have only one destination, the orbiting satellite, which means that it is required to transmit energy only to the satellite. The transmitting earth station therefore normally con-

sists of a large antenna and a high power amplifier. Since it is expensive and complicated to generate an equally high power in the satellite, the output power from the satellite is generally much smaller. Due to this, the receiving earth stations have to use larger receiving antennas; up to 30 metres in diameter, in the early days of satellite communications.

However, due to larger satellites, i.e. higher output power, and to better receiving technology, the earth stations can use smaller and cheaper antennas, e.g. satellite TV broadcasting.

## 2 A brief historical review

The first person to suggest the use of the geostationary orbit for communication satellites, was the English physicist Arthur C Clark (born 1917). He published his article "Extra-Terrestrial Relays" in the Wireless World Magazine in October 1945. In this article a satellite system for broadcasting of television, was described. At that time there was a discussion going on about how to distribute television. The present technology was not mature for the construction of reliable and unmanned satellites. In 1945 no-one could predict the rapid development within electronics, e.g. the invention of the transistor in 1947.

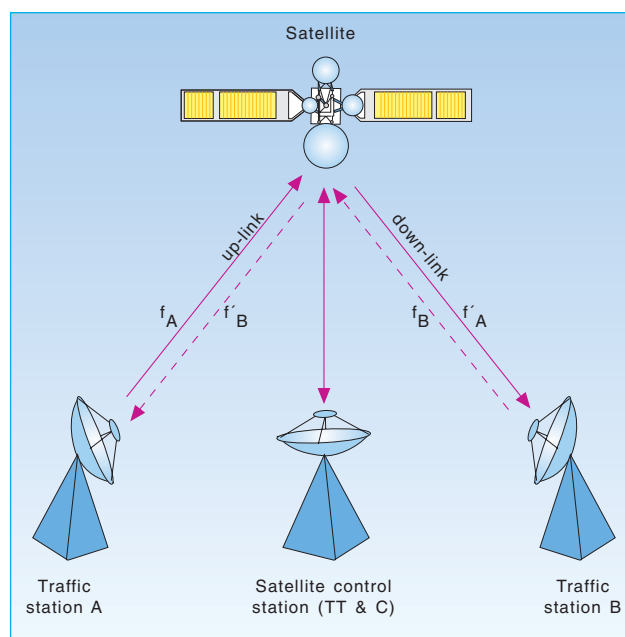


Figure 1 The main building blocks in a two-way satellite communication system

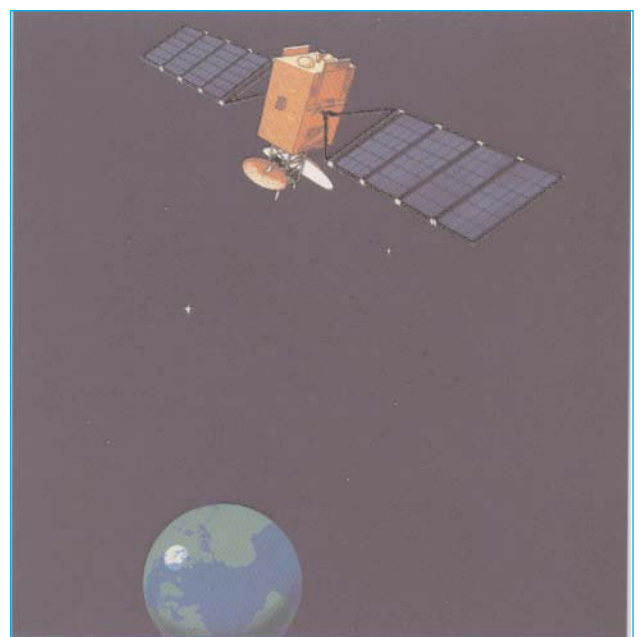


Figure 2 A geostationary satellite "illuminating" the coverage area on earth

The Space Age started with the launching of the first artificial satellite, Sputnik-I, in 1957. It is worth while noticing that the first trans-Atlantic telephone cable was stretched the same year. In the following years several satellites were launched, both for scientific purposes and for other specific applications. Communication experiments with passive reflecting satellites, Echo-I and -II (1960), were also carried out.

An operational system with passive satellites was never realised, but the project made essential contributions to the development of the earth station technology.

The first active telecommunication satellites were launched in the early 1960s, Courier (1960), Telstar-I and -II (1962 and 1963) and Relay-I and -II (1962 and 1964).

They were all put into low earth orbits, the height varying between 1,000 and 8,000 km. Telstar-I was the most important of these satellites, figure 3. This satellite transmitted television directly from USA to England and France for the first time. The Nordic countries started early to make use of satellite communication. In 1964 the Nordic countries built a common receive earth station at Råö, outside Gothenburg. It was an experimental earth station which participated in NASA's experiments with the Relay satellites.

The first satellite in the geostationary orbit was Syncom-II in 1963. The launch of Syncom-I the same year was a failure. This was an important breakthrough for commercial satellite communication. Several important experiments were carried out. One of them

Launch data	
Date:	10 July 1962
Vehicle:	Thor-Delta
Orbital data	
Orbit:	Elliptical
Inclination:	44.8 degrees
Apogee:	5653 km
Perigee:	936 km
Period:	157.8 min
Satellite data	
Weight:	77 kg
Diameter:	0,9 meter (spherical)
No of transponders:	1
Bandwidth:	50 MHz
Output power:	3 Watts

Figure 3 The Telstar satellite, main data. The satellite was designed and built by Bell Telephone Laboratories and launched by NASA

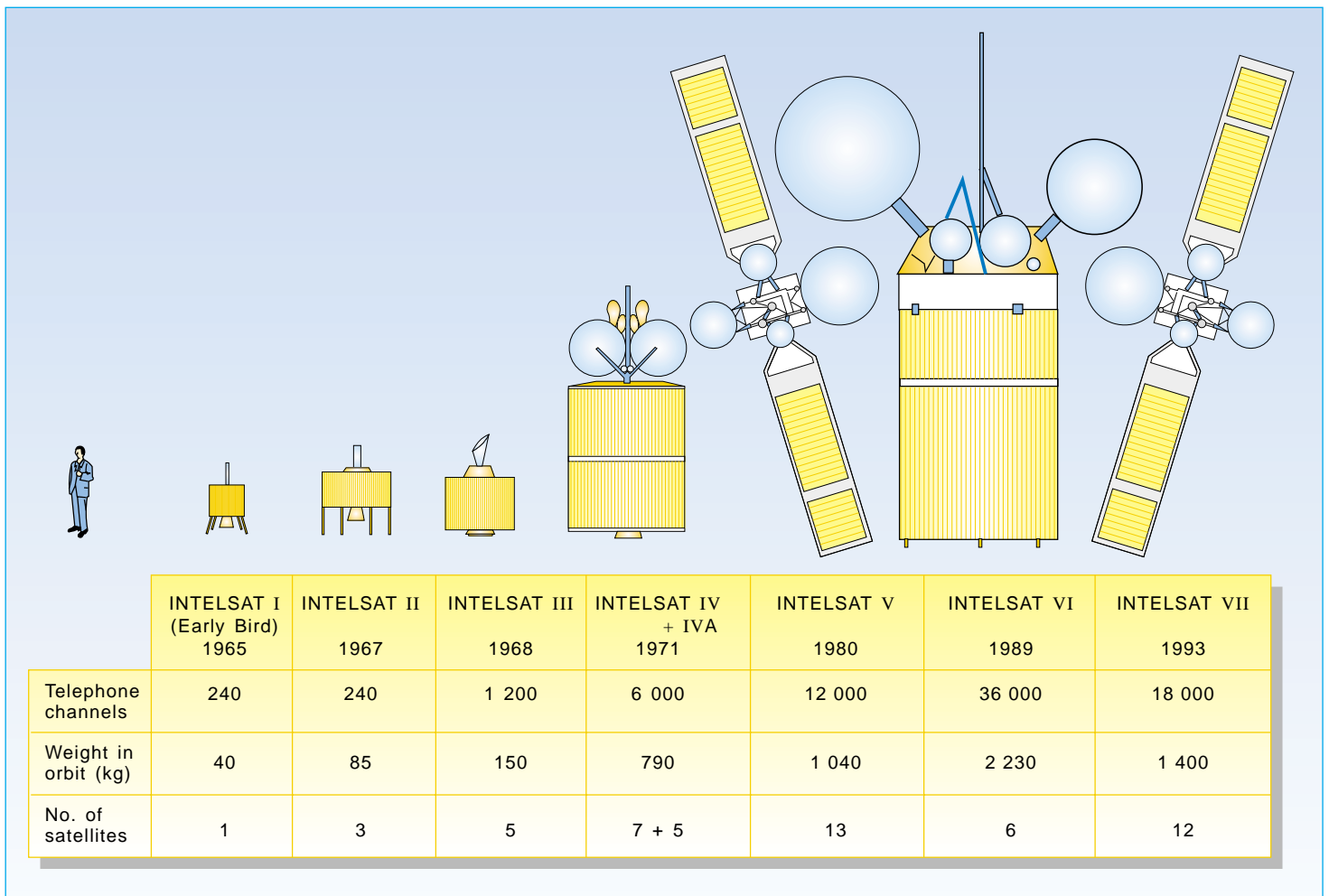


Figure 4 The INTELSAT satellites. Technical development

was to examine whether or not geostationary satellites could be a part of the public telephone network. The problem was the time delay of the radio signal. With a mismatch at the other end of the connection, one would hear oneself half a second later. This was thought to be a major obstacle for a two-way telephone conversation. Effective echo cancellers were then developed. This reduced the problem to such a degree that the telephone users accepted a connection via satellite.

In 1965, the first commercial geostationary satellite, Early Bird, was placed in a position over the Atlantic Ocean. This became the first satellite in the international organisation for telecommunication satellites, INTELSAT. A preliminary agreement was made in 1964 between 11 countries, but the final agreement was not signed until 1973. This organisation has been the leading one in the development of communication satellites. Over 100 countries are members, and there are almost 600 earth stations in 170 countries. INTELSAT has launched 35 geostationary satellites and only six have been unsuccessful.

Figure 4 shows the development of the INTELSAT system.

The first Nordic INTELSAT earth station was built in 1971 at Tanum in Bohuslän. This earth station communicates with

geostationary satellites over the Atlantic and Indian Oceans. The first European commercial communication satellite, EUTELSAT-I, was launched in 1983.

### 3 Applications

The most important application of satellite communication has up till now been inter-continental telephone and TV transmissions. This was the first application and is still the most important. Large and expensive earth stations with antennas up to 20 m in diameter are employed. The INTELSAT-A system is an example of this.

The rapid development in the satellite technology and the use of more powerful launch vehicles has led to the use of satellite systems in more restricted areas. As an example the Norwegian Telecom employs satellites as a part of its domestic telecommunication network and offers satellite connections between the Norwegian mainland and the oil installations in the North Sea, figures 5 and 6, as well as to the Arctic islands of Svalbard (the NORSAT-A system). This system transmits via one of the satellites in the INTELSAT system.

The main station in the NORSAT system is located at Eik in the south western part of Norway. It was put into operation in 1976 and was the first earth station in Europe intended for domestic traffic.

Svalbard was connected to the terrestrial public network via this system in 1979 with an earth station at Isfjord Radio, figure 7. The TV broadcasting to Svalbard was established via one of the EUTELSAT satellites in 1984.

Regional systems can make use of satellites with global, semi-global or spot coverage. This can be achieved by larger satellite antennas. The European EUTELSAT system is a satellite system with several application areas. The development of this system started in 1970. The system intended to

- transmit telephony traffic between large national earth stations
- exchange TV programmes (Eurovision)
- cover the need for special services (as business communication)
- distribute TV programmes to cable networks.

The first satellite system for maritime mobile communication, MARISAT, became operative in 1976. This system is now replaced by the INMARSAT system. The first operational European coastal earth station was put into service at Eik in Norway in 1981. This station will now expand to cover satellite communication with aeroplanes

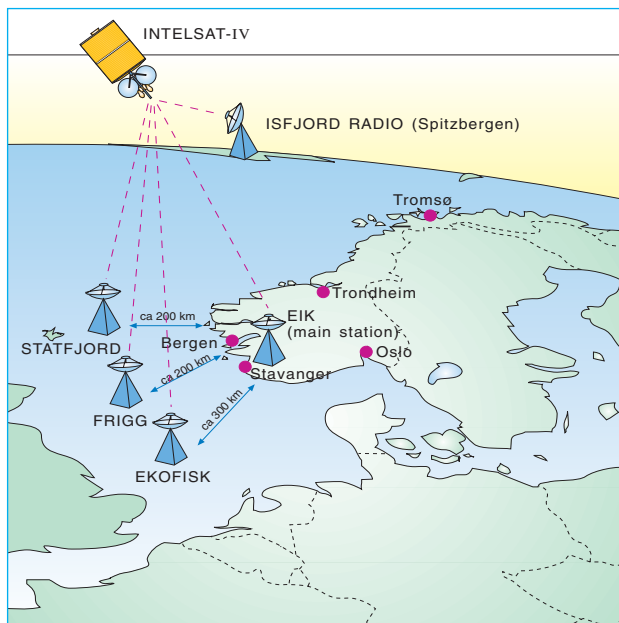


Figure 5 The NORSAT-A system started in 1975. The initial system used leased capacity on an INTELSAT-IV satellite



Figure 6 NORSAT-A earth station on an oil rig in the North Sea



Figure 7 The earth station at Isfjord Radio, Spitzbergen, 78° North. At this station the maximum elevation angle towards a geostationary satellite is 3.1°



Figure 9 Nittedal earth station outside Oslo, Norway

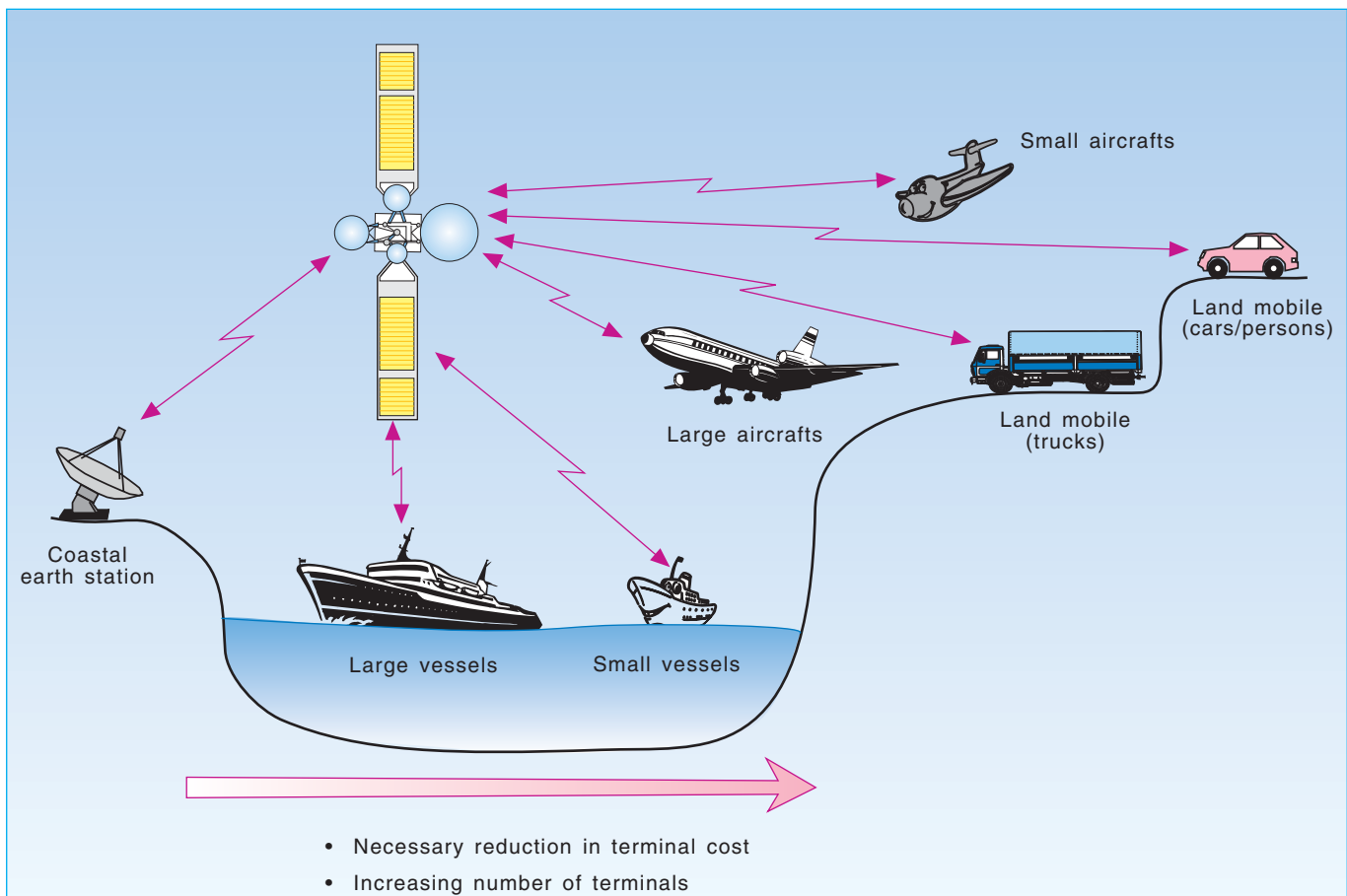


Figure 8 Mobile satellite communication system

(INMARSAT AERO). The evolution points at communication with even smaller units such as trucks, private cars and individuals, figure 8.

As the satellites become more powerful it is possible to make simpler earth station equipment. Then the satellite terminals can be located closer to the user. This is done in the VSAT systems which are mainly used for business communication. The Norwegian Telecom has established an earth station at Nittedal, 1987, for European data communication via the EUTELSAT system, figure 9, as well as a traffic control station at Eik for business communication, the NORSAT-B system. The NORSAT-B system offers connections between unmanned earth stations in Europe.

The last application area is broadcasting of television and sound. This is a point-to-multipoint system where we make full use of the advantage of satellite communication. One satellite in geostationary orbit will cover 97 % of all households in Norway. Today more than 100 television programmes are transmitted via satellite to European countries. Arthur C Clarke's original idea from 1945 has become a reality. Figure 10 shows the total involvement of the Norwegian Telecom in satellite communication.

lites, e.g. the space shuttle, has an orbital period of approximately 1.5 hours. An example of a satellite with a long period of revolution is the moon. Due to the long distance from earth (ca 385,000 km) the period is about 27 days.

The orientation of the orbit with respect to the earth's equatorial plane may also be different, i.e. inclined orbits.

The movements of a satellite are determined by the laws of Newton (1642 - 1727) and Kepler (1571 - 1630). Applied to satellites Kepler's laws are:

- 1 The satellite orbit is an ellipse with the earth at one focus.

#### 4 Orbital considerations

A satellite's period of revolution is determined by the distance from the earth. The farther from earth, the longer the period. The nearest satel-

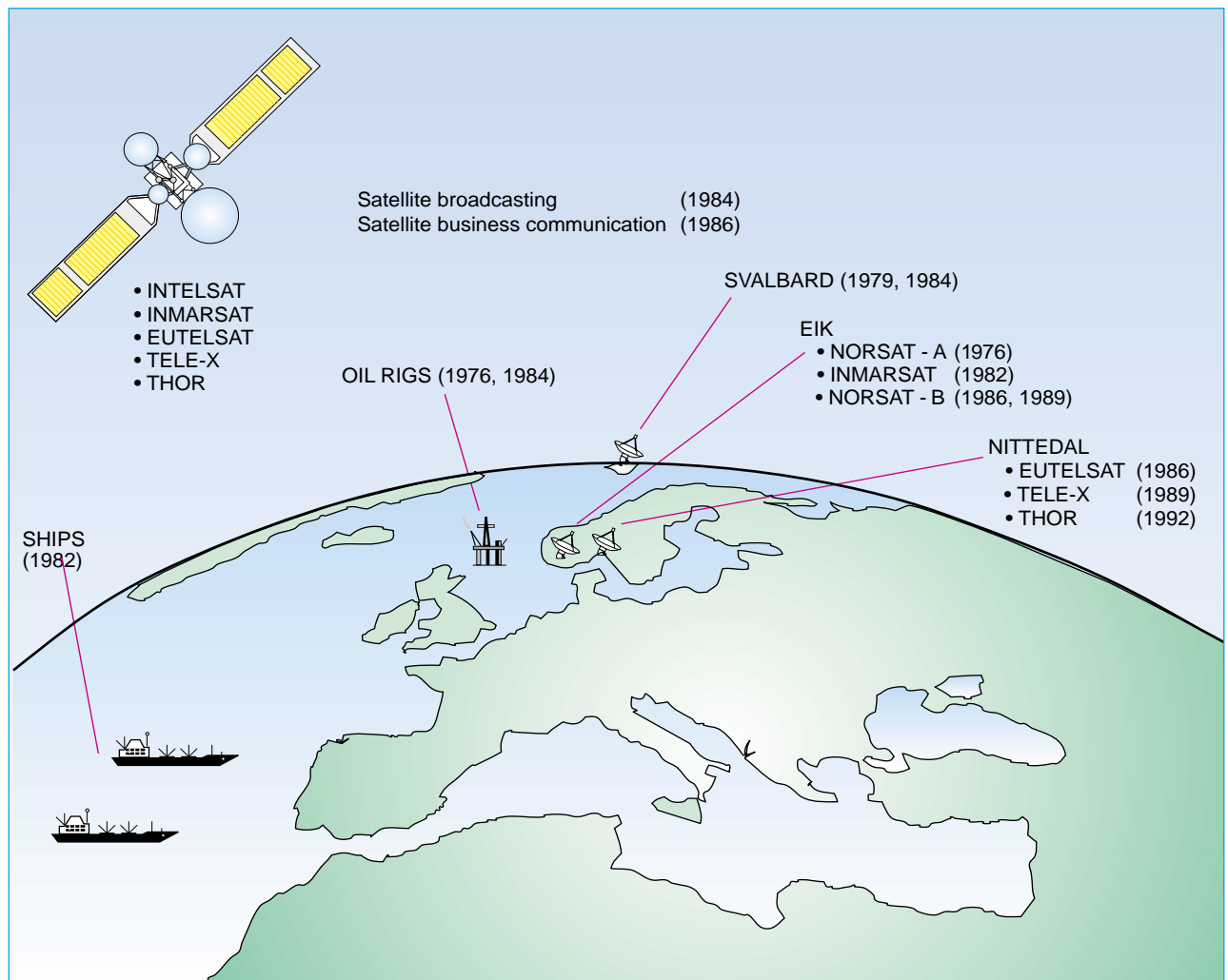


Figure 10 The Norwegian satellite involvement; main earth stations and utilized satellites



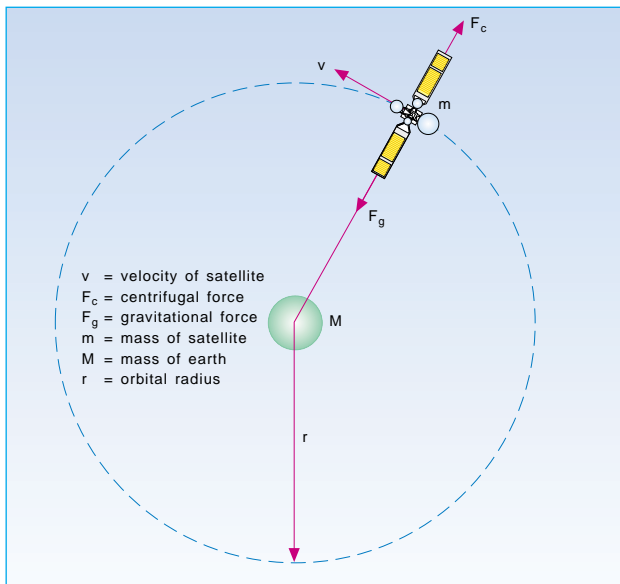


Figure 11 Forces acting on a satellite in a circular orbit

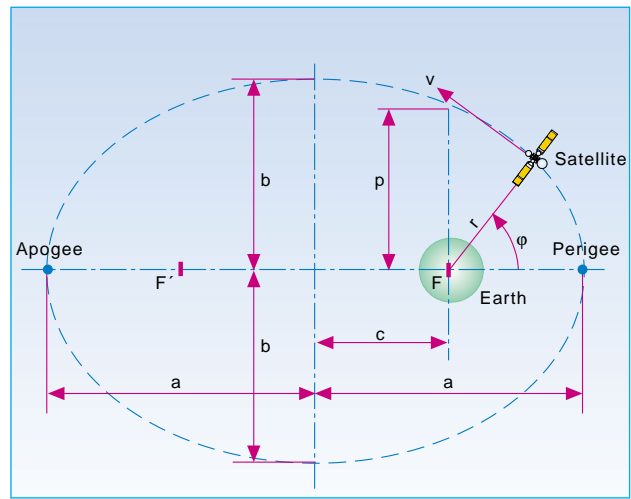


Figure 12 The elliptical satellite orbit with major and minor semi-axis  $a$  and  $b$  and eccentricity  $e = c/a$ . The semilatus rectum  $p = h^2/\mu$  where  $h = v \cdot r$  (the angular momentum per unit mass)

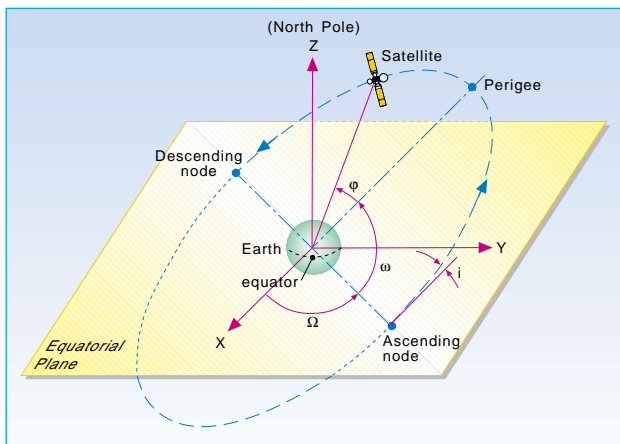


Figure 13 The geocentric equatorial coordinate system. The z-axis coincides with the rotational axis of earth. The x,y-plane cuts through the earth's equator and is called the equatorial plane. The x-axis is the direction from the centre of earth through the centre of sun at the vernal equinox ( $\approx 21$  March), see figure 14

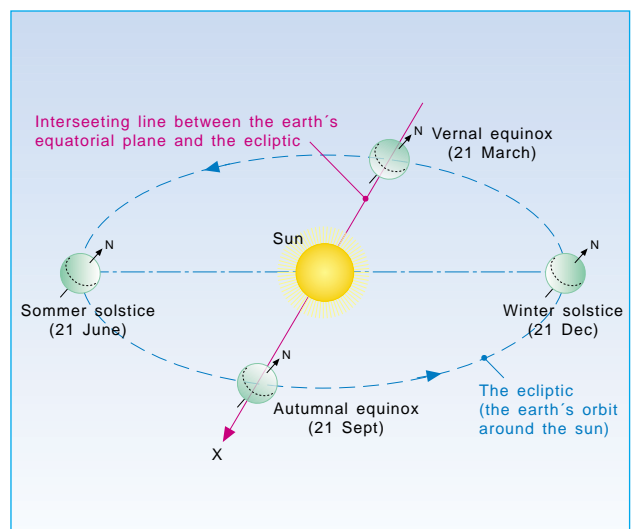


Figure 14 Definition of the x-axis in the geocentric equatorial coordinate system

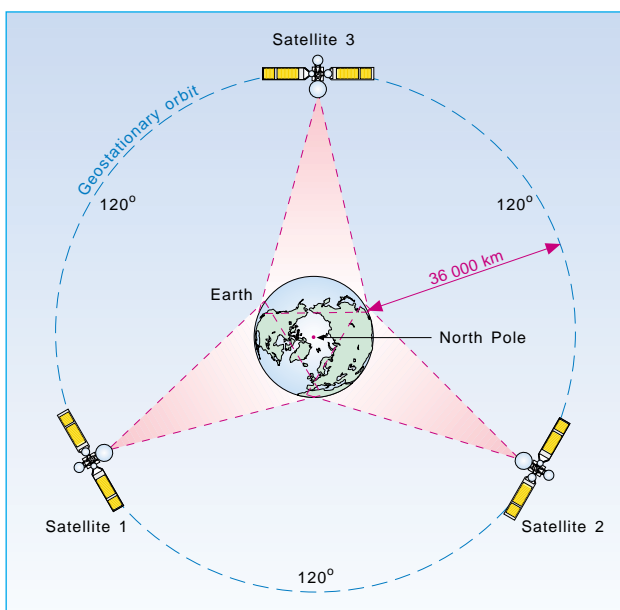


Figure 15 Three satellites in the geostationary orbit will almost cover the whole earth

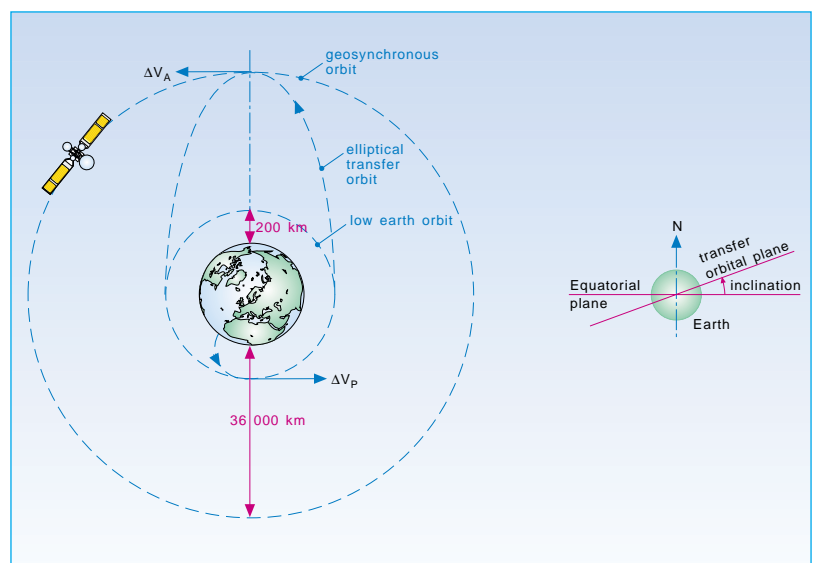


Figure 16 a) and b) Orbits for launching of geosynchronous satellite. The inclination of the transfer orbital plane is equal to or larger than the latitude of the launch site

- 2 The radius vector to the satellite sweeps out equal areas in equal times.
- 3 The square of the period of revolution is proportional to the cube of the orbit's semi-major axis.

Considering a circular orbit, the forces acting on the satellite are shown in figure 11.

With reference to figure 11, the gravitational force  $F_g$  on the satellite is given by Newton's law:

$$F_g = G \frac{M \cdot m}{r^2} \quad (4.1)$$

where  $G$  is the universal gravitational constant.

According to Newton's general law of motion, the centrifugal force is given by

$$F_c = ma = m \frac{v^2}{r} \quad (4.2)$$

Counterbalancing of forces,  $F_c = F_g$  gives

$$G \frac{M \cdot m}{r^2} = m \frac{v^2}{r} \quad (4.3)$$

or the satellite velocity

$$v = \sqrt{\frac{G \cdot M}{r}} \quad (4.4)$$

The period of orbit,  $T$ , is given by

$$T = \frac{2\pi r}{v} \quad (4.5)$$

Inserting for the satellite velocity, equation (4.4), the period will be

$$T = 2\pi \sqrt{\frac{r^3}{G \cdot M}} = 2\pi \sqrt{\frac{r^3}{\mu}} \quad (4.6)$$

where  $\mu = G \cdot M = 398\,600 \text{ km}^3/\text{sek}^2$  (Kepler's constant).

This expression is a mathematical statement of Kepler's third law. This equation applies even if the orbit is elliptical, substituting the radius  $r$  with the semi-major axis  $a$ .

An elliptical orbital geometry is shown in figure 12.

The equation describing the orbit in polar co-ordinates ( $r, \phi$ ) is

$$r = \frac{p}{1 + e \cos \phi} \quad (4.7)$$

where

$$p = \text{semi-latus rectum} = \frac{h^2}{\mu}$$

$$e = \frac{c}{a} = \text{eccentricity} \quad (0 < e < 1)$$

$a$  = major semi-axis

$h = v \cdot r$  = the angular momentum per unit mass

The earth is located in  $F$ , one of the two foci. When the two foci coincide ( $e = 0$ ) the orbit will be a circle. The point closest to earth is called "perigee" and the farthest point is called "apogee". The angle ( $\phi$ ) measured from the perigee to the satellite is called the *true anomaly*.

The true anomaly, eccentricity and length of the semi-major axis determine the satellite's position in the orbital plane. In order to locate the satellite in space, we need information about the orbit's orientation. We introduce a fixed reference co-ordinate system called the geocentric equatorial co-ordinate system, figures 13 and 14. This co-ordinate system moves with the earth around the sun, but it does not rotate.

The intersection of the equatorial plane and the orbital plane is called the line of nodes. The ascending node is the point where the satellite is crossing the equatorial plane from south to north. The angle between the x-axis and ascending node is called the *right ascension (RA) of the ascending node* ( $\Omega$ ). The angle between the ascending node and perigee ( $\omega$ ) specifies the orientation of the ellipse, and is called the *argument of perigee*. The *inclination* ( $i$ ) of the orbital plane is the angle between the equatorial plane and the orbital plane.

The five orbital elements,  $a, e, \Omega, \omega,$  and  $i$ , completely define the satellite's orbit around the earth. These elements are time independent. The last element,  $\phi$ , specifies the satellite's position in its orbit, and is the only time dependent parameter.

For communication satellites there is one orbit which is particularly interesting. This is the near circular equatorial orbit with period of revolution equal to the rotational period of earth (24 hours). A satellite in this orbit will follow the earth's rotation, and for an observer on earth's surface, the satellite will appear to be "fixed in the sky".

This orbit is called the geostationary orbit (GEO).

The geostationary satellite has a period of revolution a little under 24 hours, due to the fact that the earth moves around the sun in one year. This means an extra revolution with respect to the fixed stars. The period of a GEO satellite will accordingly be

$$T = \left( \frac{365.25}{365.25 + 1} \right) \cdot 24 \cdot 60 \cdot 60 = 86\,164 \text{ sec}$$

Using equation (4.6) we can now calculate the radius of the geostationary orbit:

$$r = \left[ \mu \left( \frac{T}{2\pi} \right)^2 \right]^{1/3} = 42\,164 \text{ km}$$

The satellite's height above the earth's surface will be:

$$h = r - R_j = 35\,786 \text{ km}$$

where  $R_j = 6\,378 \text{ km}$  = equator radius of the earth.

The satellite's velocity is:

$$v = \frac{2\pi r}{T} = 3.075 \text{ km/sec}$$

From a satellite in the GEO orbit approximately 42 % of the earth's surface will be visible. Accordingly, with 3 satellites in the GEO orbit, we will have almost full coverage of the earth, except for areas above  $81^\circ$  latitude north and south, figure 15.

Our problem with the geostationary satellites is the transmission delay of the radio signal between the earth and the satellite. Since radio waves propagate with the speed of light (300 000 km/s) the time delay will be about 270 milliseconds to and from the satellite. This was in the early days considered to be a major problem for speech connections via GEO satellites. However, it showed up that the problem was much less than anticipated as mentioned previously.

In the last few years other orbits than the geostationary have been reconsidered with great interest, especially low earth orbits for mobile satellite services, and highly inclined elliptical orbits for broadcasting services, ref Hovstad/Gutteberg: "*Future systems for mobile satellite communications*" (this issue).

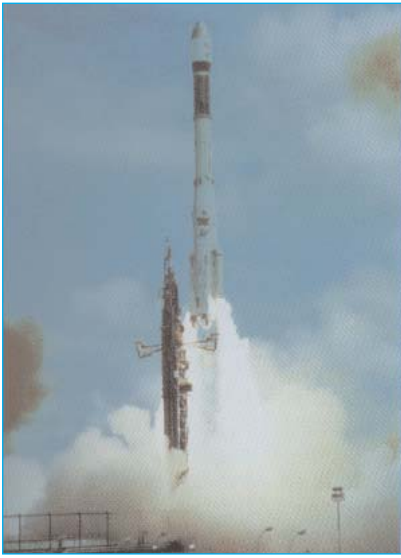


Figure 17 Multistage launcher Ariane

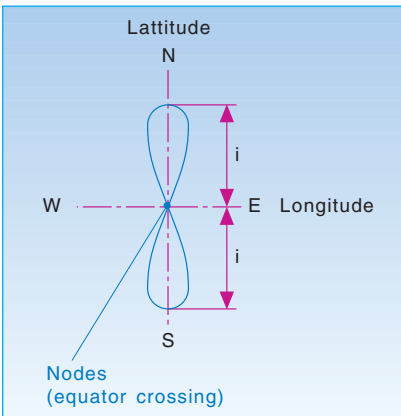


Figure 19 Apparent movement of satellite in an inclined synchronous orbit

## 5 Launching

For a satellite to achieve the geostationary orbit, it must be accelerated to 3.075 km/s at a height of 35 786 km with zero inclination. Theoretically, one can place the satellite directly into the geostationary orbit in one operation. However, considerations regarding costs and launching capabilities call for a multistage launch vehicle (2 - 4 stages). The launching of the satellite represents a major part of the total investments in a satellite system.

The conventional, and most economical, method of launching a satellite is based on the use of the Hohmann transfer orbit,

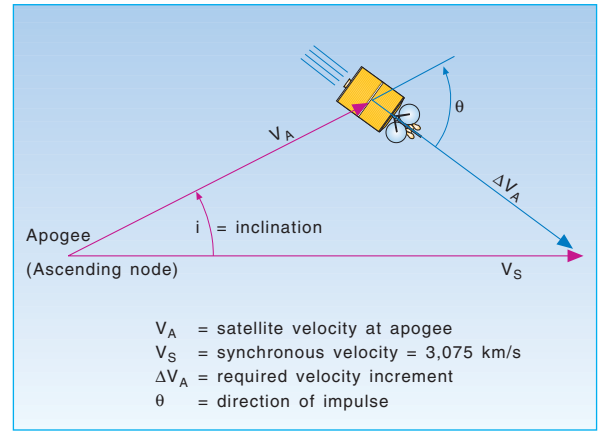


Figure 18 Velocity diagram on a plane normal to the line of nodes

figure 16. For the following reasons, the launch site should be near equator:

- (i) To make maximum use of the surface velocity of the earth
- (ii) To achieve minimum inclination. This will give minimum velocity increment for the correction of the inclination. The minimum inclination achievable is equal to the latitude of the launch site.

The launch sequence is as follows: The satellite is placed into low earth orbit with an altitude of about 200 km, e.g. by the space shuttle. There must be two velocity increments; one for injection into the elliptical transfer orbit ( $\Delta V_p$ ) by the perigee kick motor and one for injection into the geosynchronous orbit ( $\Delta V_A$ ) by the apogee kick motor. The transfer orbit has an altitude of the perigee and apogee corresponding to the transfer and geosynchronous orbit altitudes, respectively.

Alternatively, one can put the satellite directly into the elliptical transfer orbit, by a multistage launcher, e.g. Ariane, see figure 17. The idea of using a multistage launcher is to get rid of the unnecessary mass, to achieve the sufficient velocity.

Correction of the inclination has to be done at one of the nodes of the transfer orbit, in order to achieve an equatorial circular synchronous orbit. The velocity increment is depending on the inclination and on the velocity of the satellite. The lower the satellite velocity, the more economical the manoeuvre. The circularization manoeuvre should therefore be carried out at apogee. This implies that the orientation of the transfer orbit has to be such that the line between the apogee and perigee is in the equatorial plane, cfr. figure 13. The altitude of the apogee has to be equal to the altitude of GEO orbit. The magnitude ( $\Delta V_A$ ) and direc-

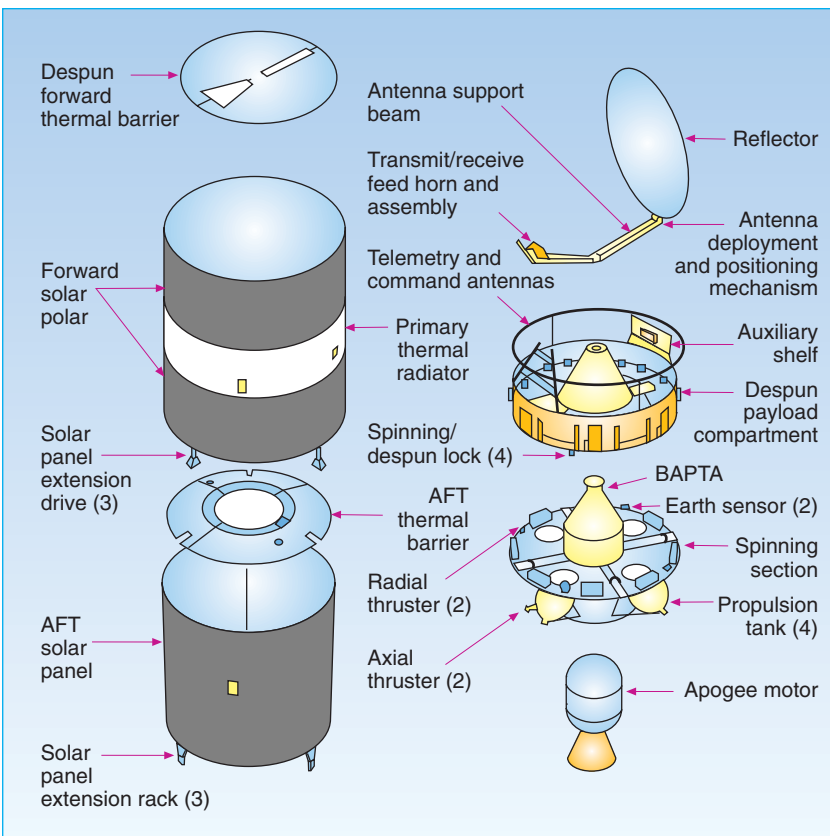


Figure 20 Exploded view of the THOR satellite

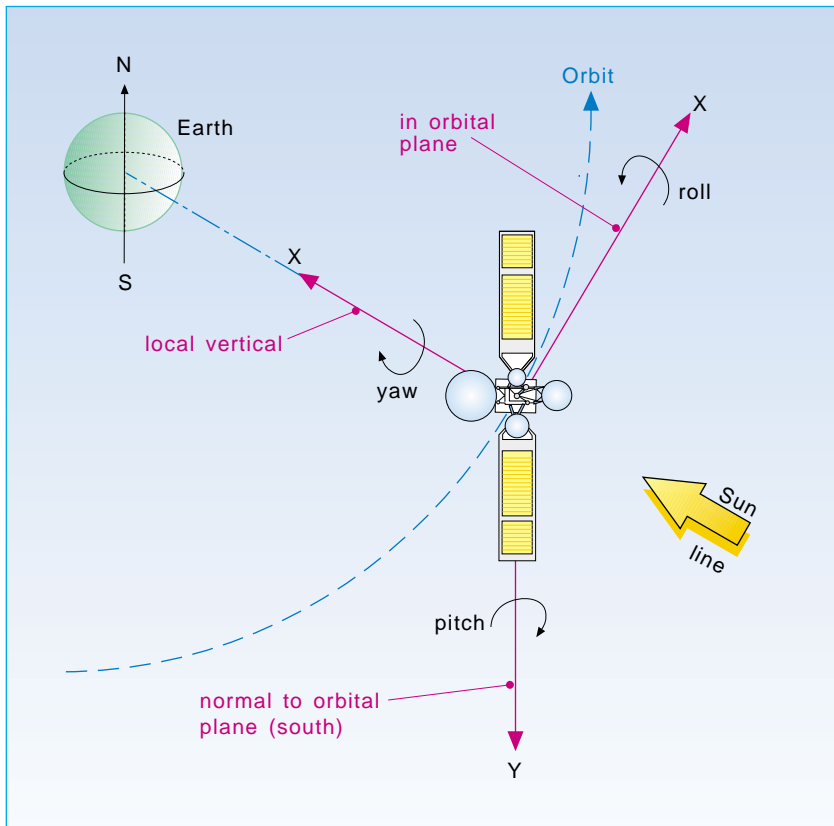


Figure 21 Definition of the reference axes, roll, pitch and yaw

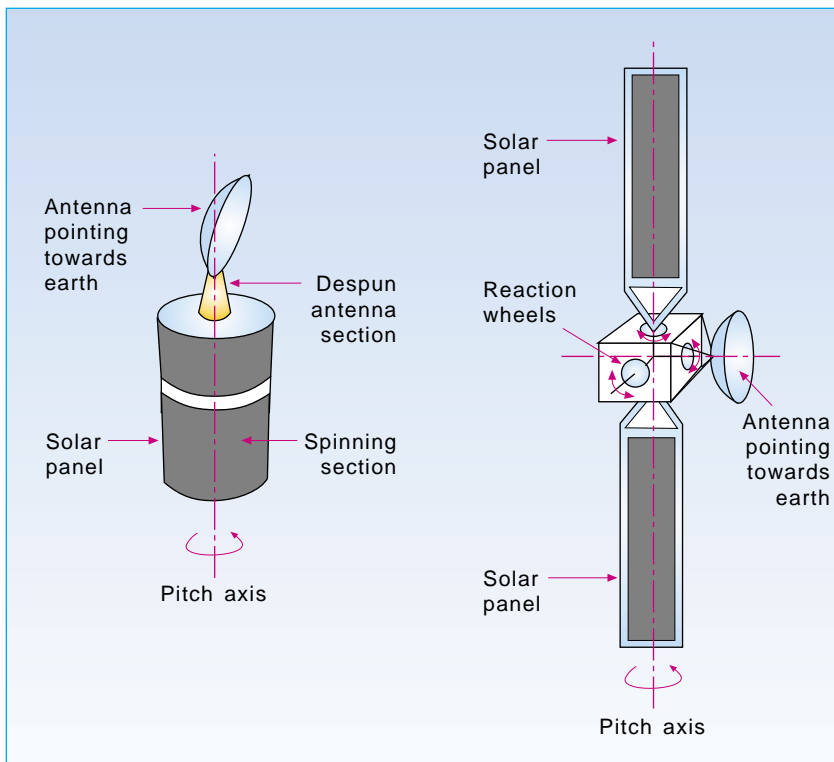


Figure 22 a) and b) The two concepts of stabilization

tion ( $\theta$ ) of the velocity vector can be calculated from figure 18. If the geosynchronous orbit has some inclination, the satellite will apparently move in a figure-of-eight with respect to the nodes, figure 19. The maximum excursion from equator in the north or south direction will be equal to the inclination.

## 6 The spacecraft

The main purpose of a communication satellite is to receive and transmit radio signals within the coverage area on the earth. This means that the spacecraft should be a reliable and stable platform for the communication system. The satellite is generally divided into two main modules:

- 1 The communication module (or the "payload") which includes
  - repeaters (or transponders)
  - antennas
- 2 The service module (or the "bus" or "platform") comprising the following subsystems
  - attitude and orbit control (AOCS)
  - telemetry, tracking and command (TT&C)
  - power supply.

Figure 20 shows an exploded view of a typical spacecraft.

### 6.1 Attitude and orbital control subsystem

The objective of the attitude control subsystem is to maintain the communication antennas correctly pointed towards the earth, and the solar cells correctly pointed towards the sun. The movements of the satellite about its centre of mass can be described by rotations about the three orthogonal reference axes: roll ( $x$ ), pitch ( $y$ ) and yaw ( $z$ ), see figure 21.

There are two different methods of controlling the attitude: spin stabilisation and body-fixed stabilisation (3-axis stabilisation), see figure 22. In the first type, the satellite spins around its main axis of symmetry. The rotation is normally about 60 rpm. This will produce an angular momentum in a fixed direction. For a geostationary satellite, the spin axis (pitch) has to be parallel with the earth's axis of rotation. To maintain the pointing of the communication antennas towards the earth, the

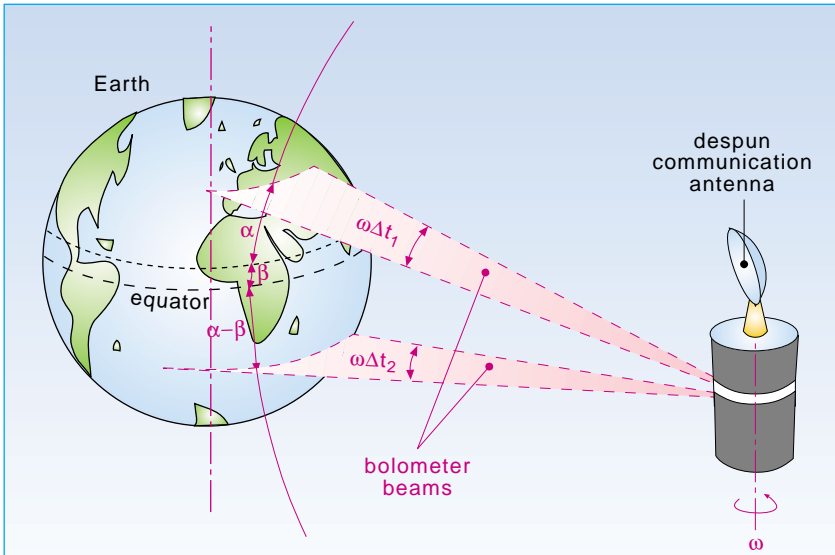


Figure 23 Earth contour detection by scanning infrared sensors (bolometers)

- $\omega =$  spin rate of satellite
- $2\alpha =$  angle between the two bolometer beams
- $\beta =$  error angle
- $\Delta t_1$  and  $\Delta t_2 =$  time between the horizon crossings

platform containing the antennas has to rotate in the opposite direction (despun). Pitch correction is done by varying the angular velocity of the despun motor, since the rate of change of angular momentum is proportional to the torque. Yaw and roll corrections are made by thrusters mounted at appropriate places on the body. A typical spin-stabilised satellite is shown in figure 20.

To keep the gyroscopic stiffness in a body-fixed stabilised satellite, one may use a momentum wheel inside the satellite. This gives rather moderate antenna pointing. Instead, it is usual to use three reaction wheels spinning around the three main axes. While the momentum wheel is spinning at high velocity (about 10 000 rpm), the reaction wheels are spinning in both direction around zero speed. By varying the speed and direction of the reaction wheels, controlling torques can be applied around all axes. When the wheels reach their maximum speed, they must be unloaded by operating thrusters on the satellite's body. A typical body-stabilised satellite is shown in figure 2. For operating the torque units, it is necessary to obtain the attitude of the satellite. This is done by sensors on board the spacecraft sensing the direction to the sun and earth. As seen from the geostationary orbit the sun subtends only  $0.5^\circ$ . It is therefore a good source for obtaining attitude reference. The sun sensor consists of photo cells which

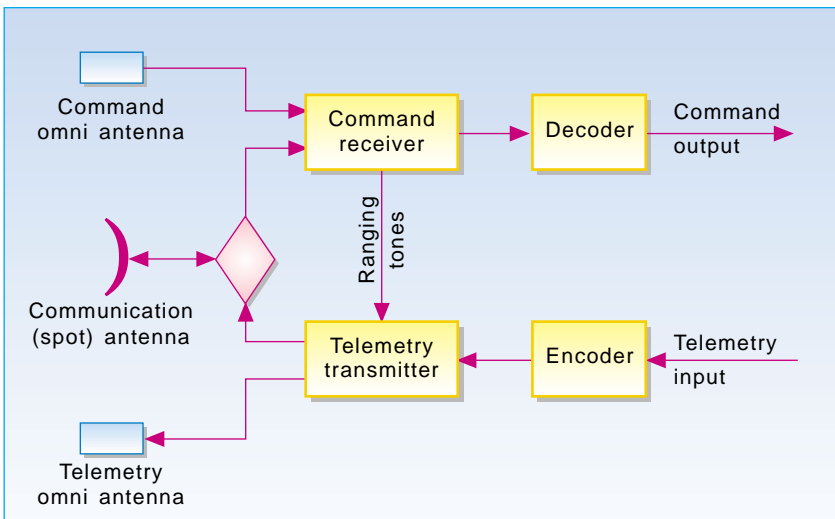


Figure 24 The satellite's TT&C system

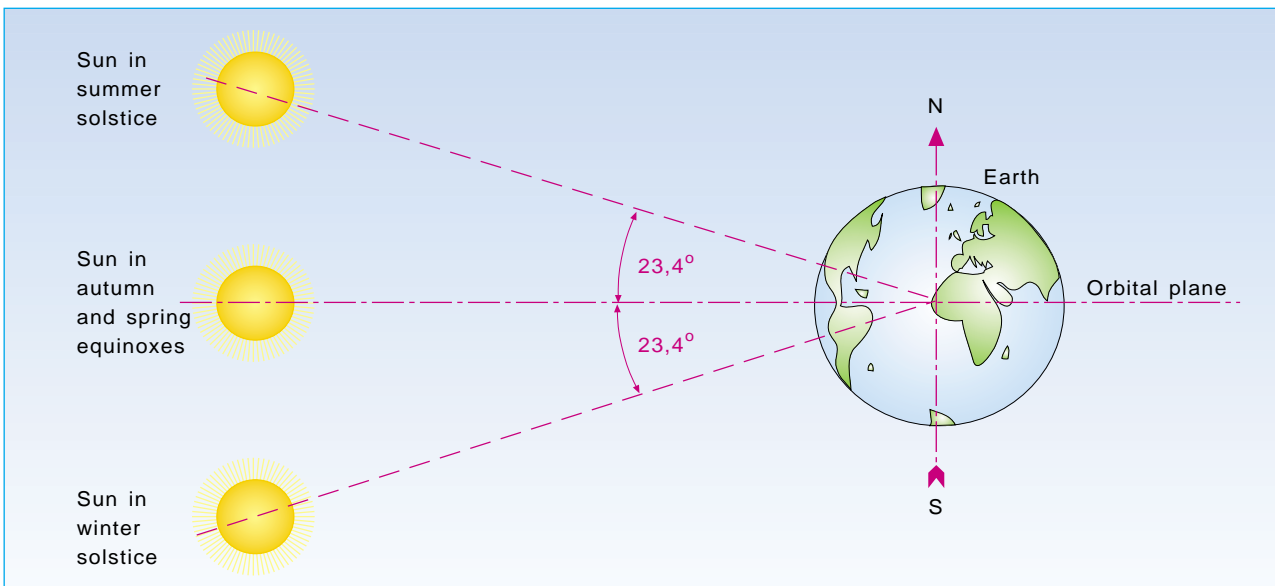


Figure 25 Apparent motion of the sun relative to earth

produce an electric current when illuminated by the sun.

The earth, seen from the satellite, has a much larger view angle ( $17.3^\circ$ ) and its centre cannot directly be measured. However, using infrared detectors (bolometers), one can measure the edge of the earth, due to the difference in radiation from the cold sky and the warm earth. Infrared detectors can be used both day and night. If two bolometers are mounted on a spinning spacecraft, as shown in figure 23, the pointing error ( $\beta$ ) can be calculated measuring the time between the two horizon crossings ( $t_1$  and  $t_2$ ), knowing the spin rate ( $\omega$ ) and the angle between the bolometer beams ( $2\alpha$ ).

On a 3-axis stabilised satellite scanning mirrors have to be used, since the satellite itself does not spin.

A higher degree of pointing accuracy may be obtained by using a radio beacon on the earth. In such a system the satellite antenna is directly locked to the transmitted radio signal from the earth beacon.

## 6.2 Telemetry, tracking and command (TT&C)

The satellite is supervised and controlled via a dedicated earth station, TT&C station, which in turn is connected to the satellite control centre (SCC). The main tasks of the spacecraft management is to control the orbit and attitude of the satellite, monitor the "health" status, remaining propulsion fuel and transponder configuration, together with steering of antennas.

The satellite's TT&C system is shown in figure 24.

The telemetry subsystem collects data from various sensors on board the spacecraft, such as fuel tanks pressure, voltages/currents in different subsystems, sighting from infrared and sunlight detectors, temperature, etc. The information rate is usually less than 1 kbit/s. The data are transmitted on a low-power telemetry carrier using an omnidirectional satellite antenna during the transfer phase and/or a spot beam antenna when the satellite is on station.

The command subsystem is used for remote control of the different functions in the satellite. This may include attitude and orbital manoeuvres, swit-

ching transponders on and off, steering antennas, firing the apogee boost motor in transfer phase, etc. When receiving a command, the command subsystem generates a verification signal, which is sent back via the telemetry link. After checking, an execute signal is transmitted to the satellite. This prevents inadvertent commands. As in the telemetry link the omni antenna is used during the transfer phase, while spot-beams are used when the satellite is in its geostationary position.

The tracking or ranging subsystem determines the orbit of the spacecraft. There is a number of techniques that can be used. One method is to measure to pointing of the TT&C earth station antenna towards the satellite, together with the slant range to the satellite, i.e. the range vector. The range to the satellite can be measured by modulating the command carrier with multiple low frequency tones ("tone ranging"). These tones are demodulated and remodulated on the telemetry carrier and received in the TT&C ground station. By comparing the phase between the transmitted and received tones, the range can be calculated. The highest tone gives the best accuracy, but several lower tones resolve the ambiguity.

## 6.3 Power supply

Solar energy is the only external energy source for orbiting satellites. The solar radiation intensity is about  $1.4 \text{ kW/m}^2$ . The sun energy is converted to electrical energy by means of photovoltaic cells (solar panels). The efficiency of the solar panels is about 10 - 15%. On the spin-stabilised satellites the solar panels form the exterior of the spacecraft's body, see figures 20 and 22.

One disadvantage of the spin-stabilised satellite is that only 1/3 of total solar array is exposed to the sunlight. On the body-stabilised satellite the solar panels are mounted on two deployable "wings", as shown in figure 2 and 22. The satellite moves around the earth in 24 hours. For intercepting maximum solar flux, the solar panel wings have to make one turn per day. They are driven by two separate motors.

A measure of efficiency is the ratio of produced electrical power to the mass of satellite. For a spinning satellite this

ratio is about 10 Watts/kg, whereas for the 3-axis stabilised satellite the ratio is about 50 Watts/kg. This means that if we need a satellite with high RF output power, we should select a body stabilised satellite. The disadvantage is that they are more complex.

On-board batteries are needed to produce power during the launch phase and when the satellite enters the shadow of the earth (eclipse). This happens around the equinoxes, and the maximum duration is approximately 70 minutes. This is due to the fact that the earth's equatorial plane is inclined with an angle of  $23.4^\circ$  with the direction to the sun, see figure 25. During the summer and winter seasons the satellite is out of the earth's shadow, figure 26, whereas during the equinoxes the satellite passes through the earth's shadow once a day for 42 days, figure 27, i.e. the satellite will experience 84 eclipses per year.

## 6.4 The communication module

The communication subsystem is the primary system in the satellite. All other functions in the satellite can be considered as supporting activities for this system. It consists of the receivers, transmitters and the communication antennas. One receive/transmit chain is called a transponder. A satellite with 5 transponders is shown schematically in figure 28. The building blocks are:

- A wide band receiver and a down converter
- An input multiplexer (IMUX)
- 5 channelised sections including the high power amplifiers
- An output multiplexer (OMUX).

The wide band receiver/converter operates in the whole up-link band, e.g. in one of the common bands

- C-band (5.9 - 6.4 GHz)
- Ku-band (14 - 14.5 GHz)
- Ka-band (17.3 - 18.1 GHz)

or other bands allocated to satellite communication.

The frequency conversion could either be single, as in figure 28, or dual. In the latter case the first mixer converts the frequency down to an intermediate frequency (IF). After the channel

amplification on IF the signal is converted up to the down-link frequency, before the last power amplification. This is often done because it is much easier to make filters, amplifiers and equalisers at an intermediate frequency. The intermediate frequency

can be chosen independently of the up- and down-link frequencies.

The input multiplexer separates the up-link band into individual channels with a certain bandwidth. For example can a 500 MHz wide up-link band be separated into 12 channels with channel bandwidth of 36 MHz. The chan-

nel bandwidths may also be unequal. The channel amplifier/attenuator sets the gain (gain-step) of the transponder in order to control the input back-off of the TWTAs. This can be done from the TT&C station by the up-link command system.

The last high-power amplifier (HPA) is usually a travelling wave tube amplifier (TWTA). This amplifier establishes the level of the output power, which may be in the range of 10 - 200 Watts depending on the application. The TWTA operates near saturation. The input/output characteristic is shown in figure 29. The output multiplexer combines all the channels before signals are transmitted to the earth by the antenna.

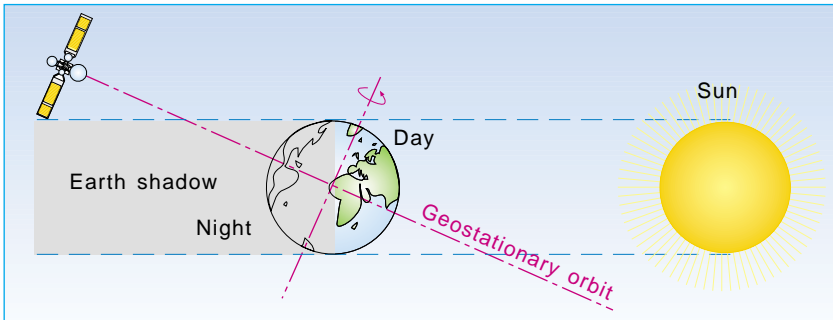


Figure 26 During summer and winter the satellite is always illuminated

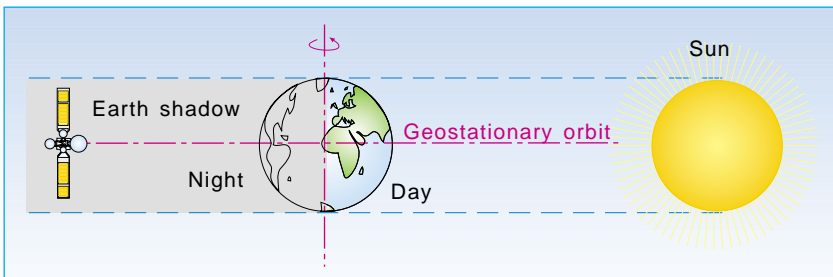


Figure 27 The satellite passes through the earth shadow at the equinoxes once a day

## 6.5 The satellite communication antenna

Antennas are used for receiving and transmitting modulated radio frequency signals from and to the earth. The most commonly used antenna in the microwave frequency band is the parabolic reflector antenna. The antenna is characterised by its radiation pattern and the maximum gain, that is the antenna's capability to concentrate the energy in one direction.

The design of the satellite antenna is depending on required coverage area,

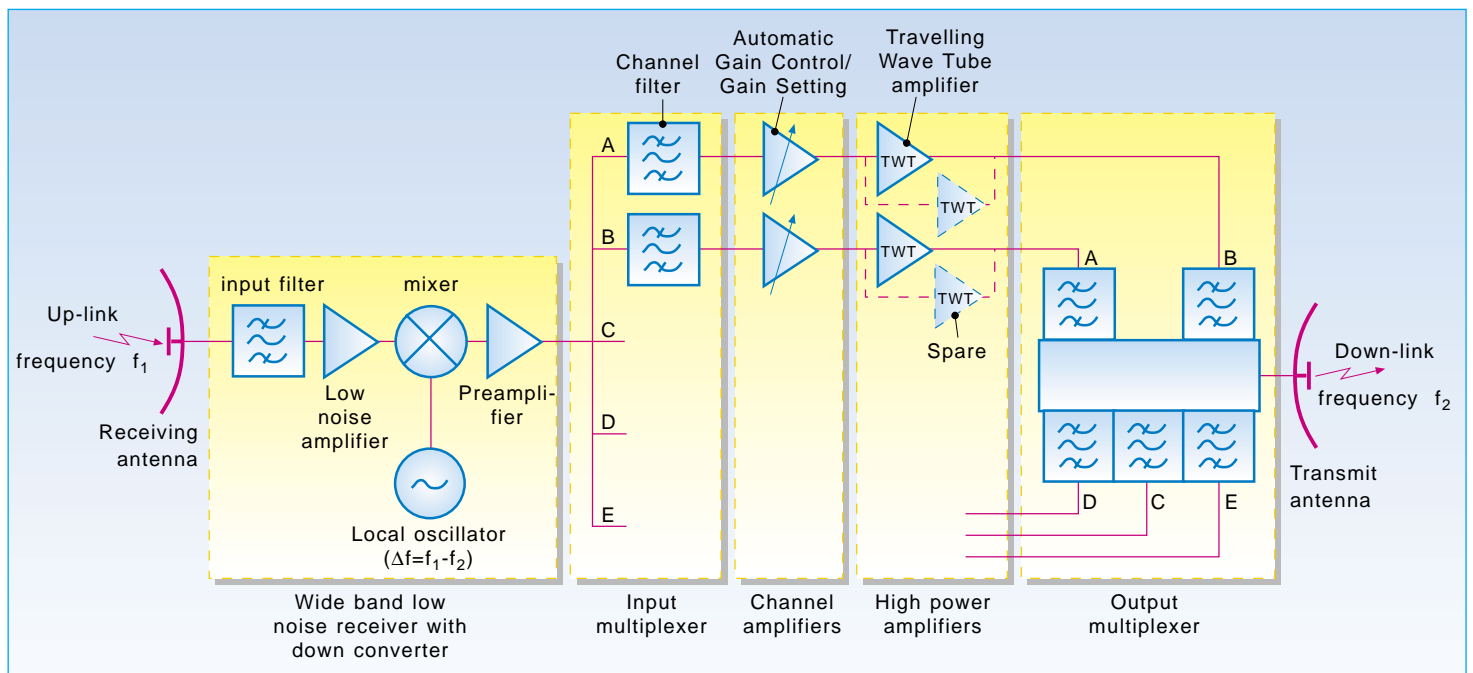


Figure 28 A satellite with 5 transponders and single frequency conversion

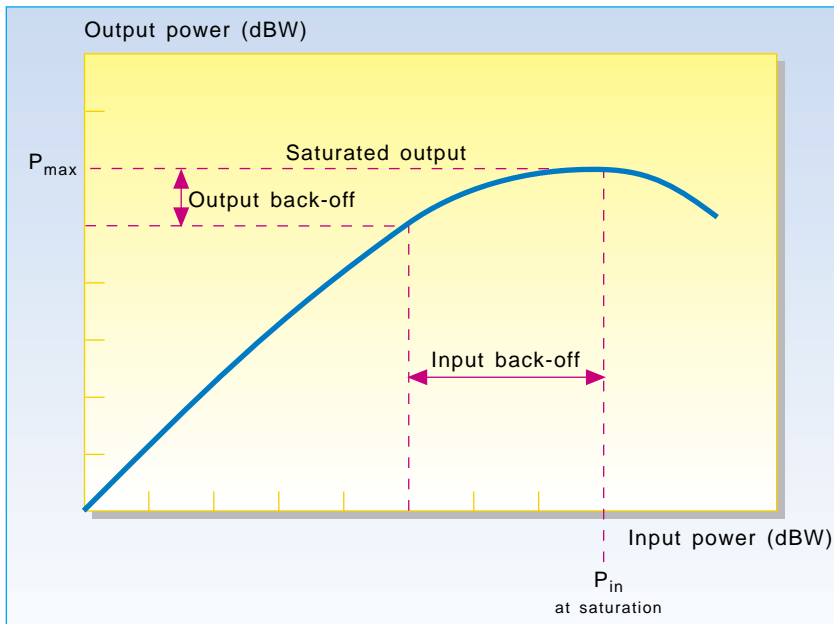


Figure 29 Input/output characteristic of a TWTA

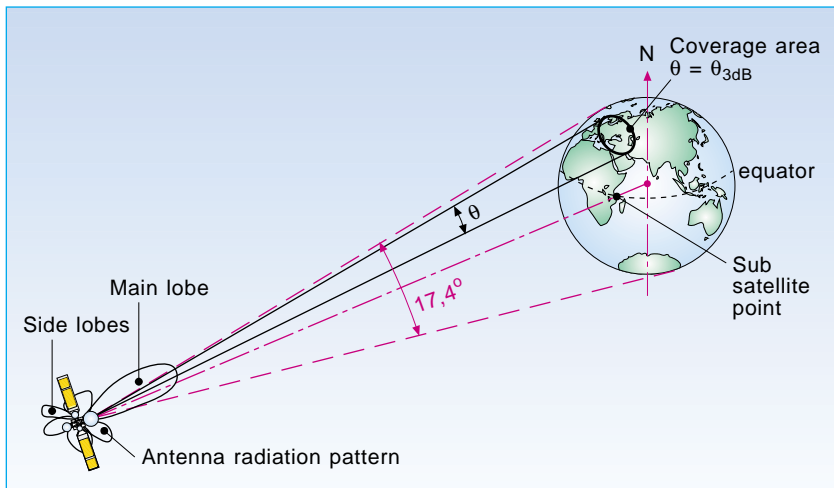


Figure 30 Coverage area of the satellite antenna. For global coverage the required beam width is 17.4°

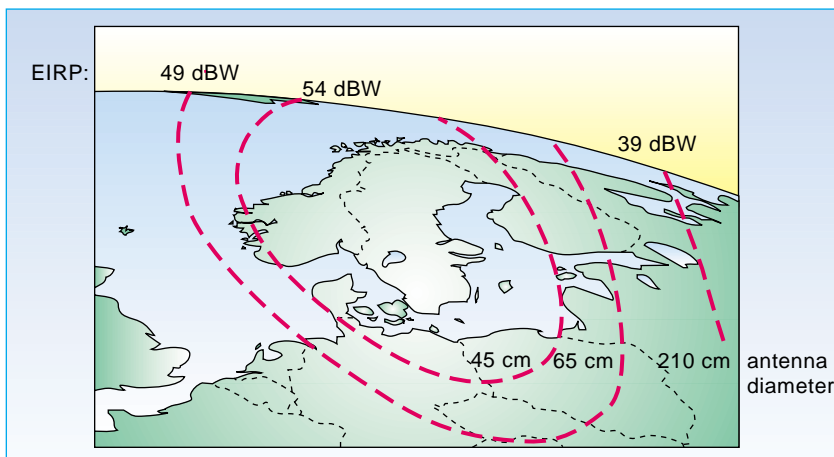


Figure 31 The preliminary EIRP contours of the THOR satellite and the corresponding receiving antenna diameter for TV reception with good quality

see figure 30. This determines the beam width of the antenna, usually taken as the half-power beam width (or 3 dB beam width). The 3 dB beam width is given by

$$\theta_{3dB} = K \cdot \frac{\lambda}{D} \text{ (degrees)} \quad (6.1)$$

where

$K = 65 - 75$ , depending on the antenna aperture field distribution

$\lambda$  = wavelength

$D$  = diameter of antenna.

The gain of the antenna is proportional to its area, and is given by

$$G = \eta \frac{4\pi}{\lambda^2} \cdot A = \eta \left( \frac{\pi D}{\lambda} \right)^2 \quad (6.2)$$

where

$\eta$  = antenna efficiency (0.5 - 0.8)

$A$  = area of antenna

or in dB:

$$G(\text{dB}) = 10 \log \left[ \eta \left( \frac{\pi D}{\lambda} \right)^2 \right] \quad (6.3)$$

Obviously the gain and the beam width of a reflector antenna are related. The gain is approximately given by

$$G = \frac{30000}{\theta_{3dB}^2} \quad (6.4)$$

where

$\theta_{3dB}$  is given in degrees.

Should the service area be the whole earth, the required beam width would be 17.4° as seen from the geostationary orbit. This corresponds to a satellite antenna with 20 dB gain. By increasing the size of the satellite antenna only a small area of the earth is illuminated. These narrow beams are called "spot beams". If we should cover an area on earth with a diameter of 300 km, the beam width of the antenna should only be 0.5°, with a corresponding gain of 50 dB. This means that we need less power from the HPA in the spot beam to achieve the same flux density on earth as in the global beam.

To express the transmitted power of a satellite, the Equivalent Isotropic Radiated Power (EIRP) is used. This is simply the product of output power



from HPA ( $P_t$ ) and satellite antenna gain ( $G_t$ ):

$$EIRP = P_t \cdot G_t \quad (6.5)$$

So instead of plotting coverage contours (or gain contours) we can plot EIRP contours. An example is given in figure 31.

A satellite can have more than one antenna. Modern satellites employ several antennas, both with global, hemispheric and spot coverage.

As described, the communication payload overall can be characterised by the following parameters:

- the coverage area
- the maximum EIRP
- the input power flux density for saturation of the output high power amplifier
- the channel arrangement or frequency plan.

## 7 The satellite link

### 7.1 The link geometry

In order to communicate with a satellite, it is necessary to know the correct pointing of the earth station antenna. We shall limit ourselves to geostatio-

nary satellites. In that case, as previously mentioned, the satellite will not move with respect to an earth station, and the antenna pointing can be fixed.

The pointing of the antenna is defined by two angles, azimuth ( $\alpha$ ) and elevation ( $\epsilon$ ). The azimuth is the angle from true north to the projection of the line to the satellite in the local horizontal plane. The elevation is the angle above the local horizontal plane to the satellite.

Knowing the satellite's position, i.e. the longitude, and the earth station position, i.e. longitude and latitude, we can calculate the earth station antenna's pointing angles. The geometry is shown in figure 32.

With the terms given in figure 32, the azimuth, elevation and distance to satellite are given by:

$$\alpha = \arctg \left( \pm \frac{tg \gamma}{\sin \phi} \right) \quad (7.1)$$

$$\epsilon = \arctg \frac{\cos \phi \cos \gamma - \frac{R_e}{R_s}}{\sqrt{1 - (\cos \phi \cos \gamma)^2}} \quad (7.2)$$

$$d = R_s \frac{\sqrt{1 - (\cos \phi \cos \gamma)^2}}{\cos \epsilon} \quad (7.3)$$

The maximum latitude coverage of a geostationary satellite ( $\epsilon = 0, \gamma = 0$ ) will be

$$\phi_{max} = \frac{\pi}{2} - \arcsin \frac{R_e}{R_s} = 81.3^\circ \text{ N or S}$$

### 7.2 Link analysis

The purpose of a satellite system is to provide reliable transmission with a specified quality of the received signal. The transmitted information has to be modulated on an RF carrier. In analogue systems, where frequency modulation (FM) is the dominating modulation method, the signal-to-noise ratio (S/N) after the demodulator is a measure of signal quality. In digital satellite links the measure of quality is the bit error rate (BER). The modulation method most often used in digital system is phase shift keying (PSK).

In both analogue and digital systems there is a unique relationship between the carrier-to-noise ratio (C/N) and the signal-to-noise (S/N) ratio or the bit error rate (BER). Given the modulation method, the performance of a total link is generally specified in terms of a minimum C/N in a certain percentage of time. In order to establish the link quality, we therefore need to calculate the carrier power (C) and the noise power (N) at the receiving station.

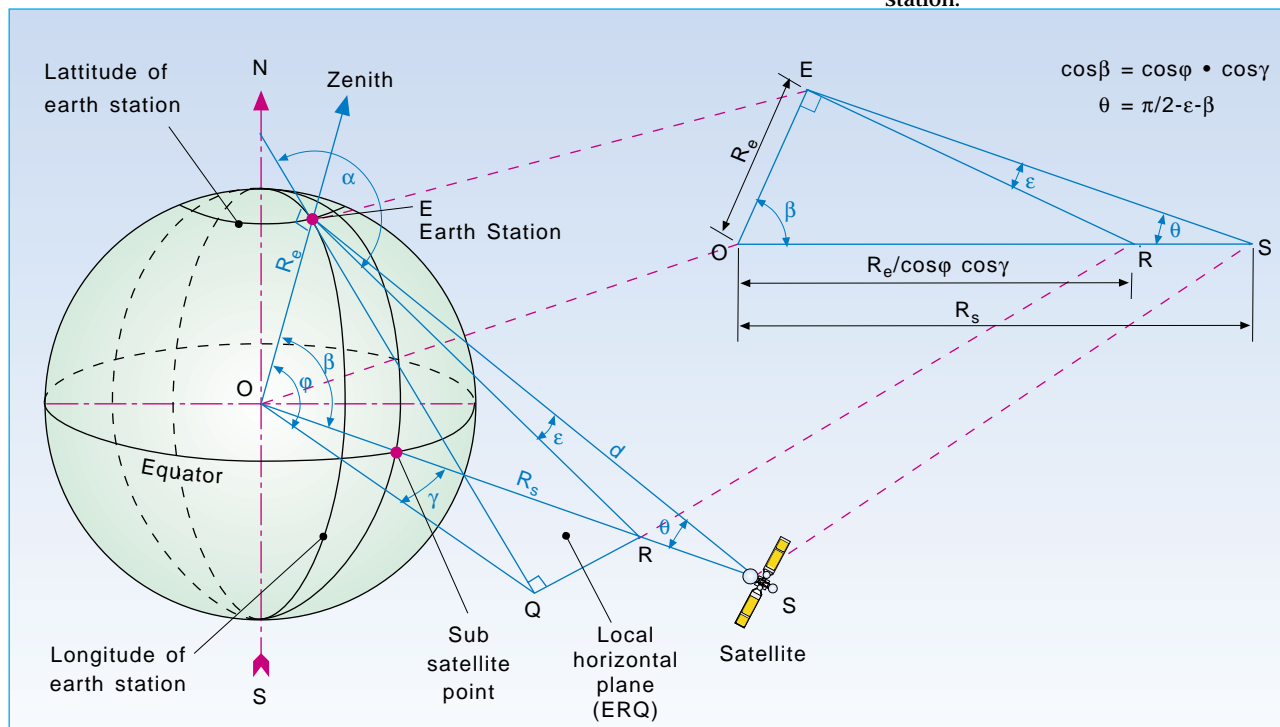


Figure 32 a) and b) Calculations of azimuth, elevation and distance to a GEO satellite

Considering an isotropic antenna, that is an antenna which radiates with uniform intensity in all directions, the power flux density (PFD) at a distance,  $d$ , will be

$$PFD = \frac{P_t}{4\pi d^2} \quad (7.4)$$

where  $P_t$  = the total radiating power. Using a directive antenna with a gain  $G_t$ , the power flux density can be increased by  $G_t$ :

$$PFD = \frac{P_t \cdot G_t}{4\pi d^2} = \frac{EIRP}{4\pi d^2} \quad (7.5)$$

If the receiving antenna has an effective area of

$$A_e = \eta A_r \quad (7.6)$$

where

$\eta$  = efficiency

$A_r$  = physical area

the received power ( $C$ ) will be:

$$C = PFD \cdot A_e = \frac{EIRP}{4\pi d^2} \cdot A_e (W) \quad (7.7)$$

Using the relationship between the effective antenna area ( $A_e$ ) and gain ( $G_r$ ), equation (6.2), the received power may be written as

$$C = EIRP \cdot \left(\frac{\lambda}{4\pi d}\right)^2 \cdot G_r \quad (7.8)$$

The term in the middle is called the free space loss:

$$L_o = \left(\frac{4\pi d}{\lambda}\right)^2 \quad (7.9)$$

In addition to the free space loss, we have several other sources of attenuation, such as atmospheric absorption, rain attenuation, etc. ref O Gutteberg: "Effects of atmosphere on earth-space radio propagation" (this issue).

All components, active and passive, produce electrical noise. This is due to the thermal agitation of electrons. The thermal noise power ( $N$ ) increases with temperature ( $T$ ) and bandwidth ( $B$ ) and is given by

$$N = kTB \quad (W) \quad (7.10)$$

where

$$k = \text{Boltzmann's constant} = 1.38 \cdot 10^{-23} \text{ W/Hz} \cdot \text{K}$$

We can now define an effective input noise temperature of a receiver (or a network). This is the temperature of a noise source located at the input of a noiseless receiver giving the same output noise power as the noisy receiver.

Noise power at the earth station receiver input has contributions both from the noisy receiver and the noise picked up by the antenna.

Hence, the total system noise temperature ( $T_s$ ) is given by

$$T_s = T_A + T_R \quad (7.11)$$

where

$T_A$  = antenna noise temperature

$T_R$  = effective noise temperature of the receiver.

The total noise power ( $N$ ) is then given by:

$$N = kT_s B \quad (7.12)$$

If the received carrier power ( $C$ ) is measured at the same point, according to the equations (7.8) and (7.12), the  $C/N$  ratio will be

$$\frac{C}{N} = EIRP \cdot \frac{1}{L_o} \cdot \frac{G_r}{T_s} \cdot \frac{1}{kB} \quad (7.13)$$

Equation (7.13) is called the link budget, and the term  $G_r/T_s$  is the receiver's "figure-of-merit". It specifies the sensitivity of the receiver, either in the satellite or in the earth station. The reference point for  $G_r$  and  $T_s$  has to be the same.

A typical receiver "front-end" is shown in figure 33. Referred to the low noise amplifier's input, the overall noise temperature is given by

$$T_s = \frac{T_A}{L} + \left(\frac{L-1}{L}\right)T_0 + T_{LNA} \quad (7.14)$$

where

$L$  = feeder loss

$T_0$  = ambient temperature = 290 K

$T_{LNA}$  = noise temperature of the low noise amplifier.

Succeeding stages of the receiver will not contribute if the gain of the LNA is sufficiently high.

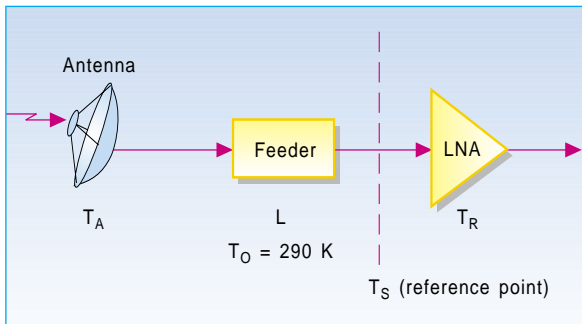


Figure 33 A typical receiver "front-end"

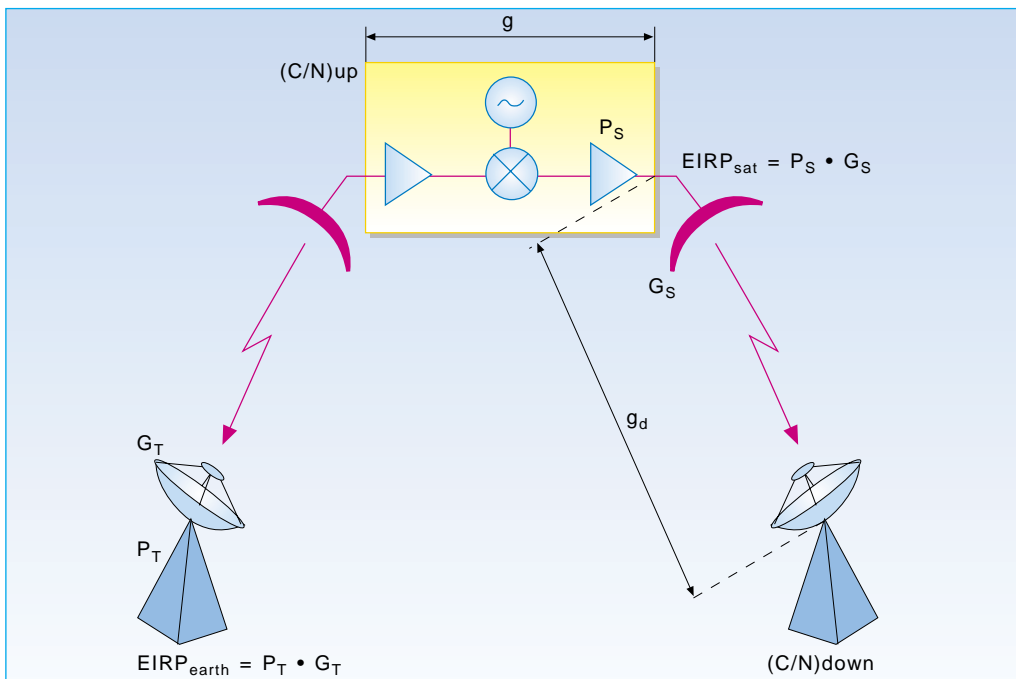


Figure 34 Basic satellite link

Instead of giving the noise temperature of a component, the noise figure ( $F$ ) is often used. This is defined as the signal-to-noise ratio at the input divided by the signal-to-noise ratio at the output:

$$F = \frac{S_i/N_i}{S_o/N_o} \quad (7.15)$$

If the source noise temperature is at the standard temperature  $T_o = 290$  K, then

$$F = \frac{S_i}{S_o} \cdot \frac{N_o}{N_i} = \frac{1}{g} \cdot \frac{N_o}{kT_o B} \quad (7.16)$$

where

$g$  = gain of the network.

Using the definition of effective input noise temperature:

$$F = \frac{k(T_o + T)B \cdot g}{kT_o B g} = 1 + \frac{T}{T_o} \quad (7.17)$$

or

$$T = (F - 1) 290 \quad (7.18)$$

A satellite system consists of both an up-link and a down-link. Noise on the up-link will also contribute to the overall noise power received at the earth station. The basic satellite link is shown in figure 34.

The total received noise power at the receiving earth station is given by

$$N_t = N_u \cdot g \cdot g_d + N_d$$

where

$N_u$  = noise power on the up-link

$N_d$  = noise power on the down-link

$g$  = total transponder gain

$g_d$  = "section gain" on the down-link (free space loss and antenna gains).

The total noise-to-carrier ratio is then

$$\begin{aligned} \frac{N}{C} &= \frac{N_{up} g g_d + N_{down}}{C} \\ &= \frac{N_{up} g g_d}{C} + \frac{N_{down}}{C} \\ &= \frac{N_{up}}{C/g \cdot g_d} + \frac{N_{down}}{C} \end{aligned}$$

since  $\frac{C}{g \cdot g_d} = C_{up}$

and  $C = C_{down}$

then

$$\frac{C}{N} = \frac{1}{\frac{1}{(C/N)_{up}} + \frac{1}{(C/N)_{down}}} \quad (7.19)$$

Using equation (7.19) we can calculate the total C/N ratio, knowing C/N ratios on the up- and down-link.

If the  $(C/N)_{up}$  is more than 10 dB above  $(C/N)_{down}$ , the noise contribution from the up-link to the down-link is only a few tenths of a dB. Often it is disregarded in link calculations where there is enough power on the up-link.

Knowing the

- location of satellite and earth station
- $EIRP$  and  $G/T$  of the satellite
- $EIRP$  of the earth station
- the required quality ( $C/N$ )
- the carrier frequencies
- the receiver overall system temperature  $T$  (or noise figure  $F$ )
- the equivalent noise bandwidth of the receiver ( $B$ )

we are now able to calculate the receiving station's figure-of-merit ( $G/T$ ) or receiving station's antenna diameter.

In figure 35 is shown the EIRP contours for INTELSAT-V A satellite in  $1^\circ$  west.

Using the above developed equations, the corresponding receiving antenna diameters have been calculated, figure 35. For the calculations the following parameters have been assumed:

$C/N = 12$  dB (TV reception with good quality)

$B = 27$  MHz (receiver noise bandwidth)

$F = 1$  dB (receiver noise figure)

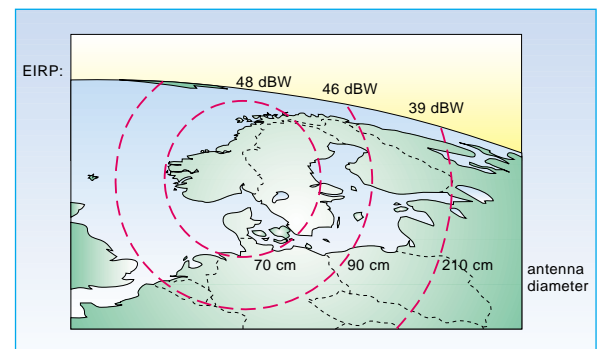


Figure 35 EIRP contours for INTELSAT-V-A at  $1^\circ$  west and the corresponding receiving TV antenna diameters. The different parameters are given in the text

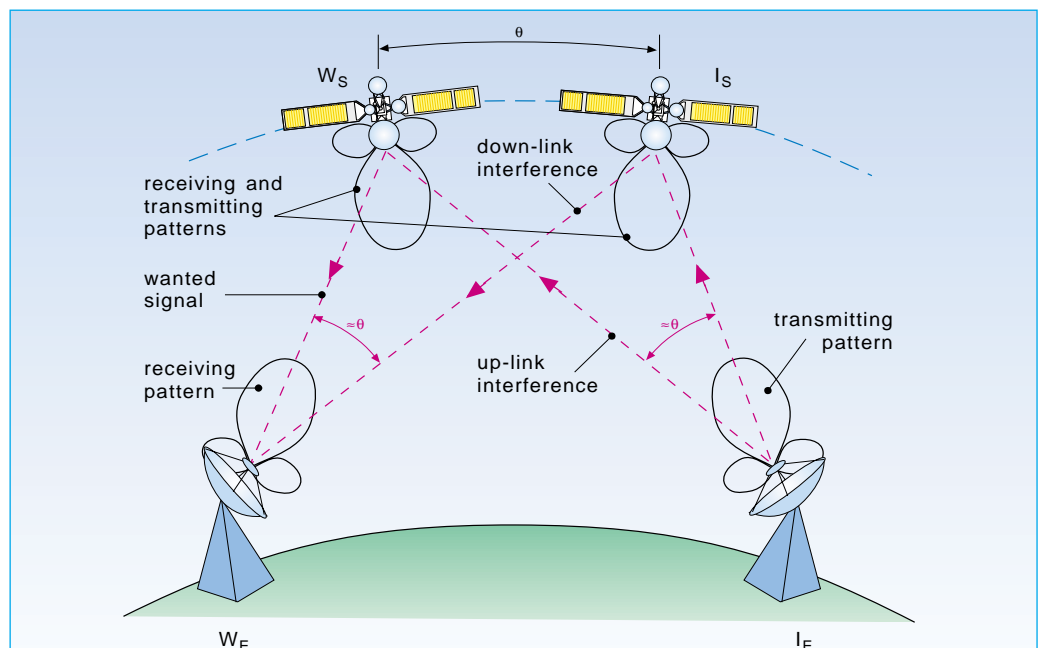


Figure 36 Simplified interference geometry

$W_s, I_s$  = wanted and interfering satellite

$W_E, I_E$  = wanted and interfering earth station

$\theta$  = angular separation between satellites

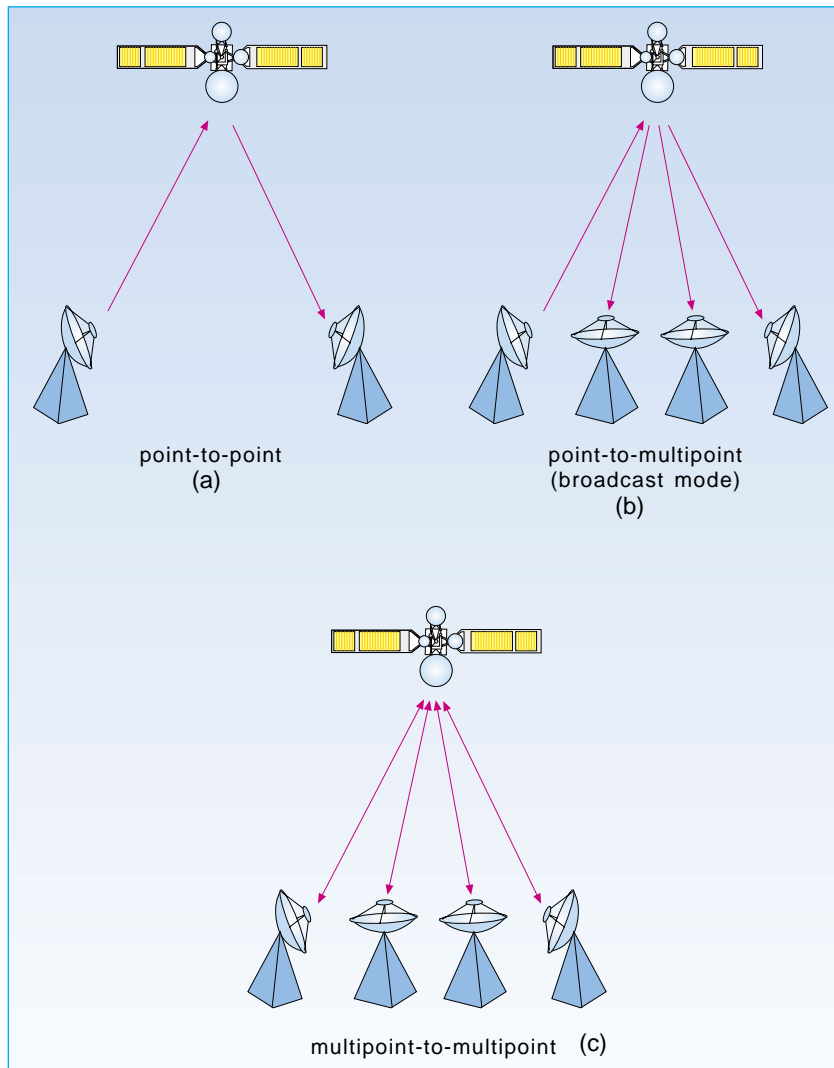


Figure 37 a), b) and c) Satellite network configurations

- $T_A = 30$  K (antenna temperature, clear sky condition)
- $L = 0.5$  dB (feeder loss)
- $f = 11.7$  GHz (carrier frequency).

Corresponding calculations have been done for the diameters given in figure 31. The noise from the up-link has been disregarded.

In the calculations above we have only considered additive thermal noise. There are also other sources of degradation such as interference from other satellites and radio links, intermodulation from the nonlinear transponder, etc. The effect of these sources are often also treated as additive thermal noise and the  $C/I$  terms should be added in equation (7.19):

$$\frac{C}{N} = \frac{1}{\frac{1}{(C/N)_{up}} + \frac{1}{(C/N)_{down}} + \frac{1}{C/I} + etc.} \quad (7.20)$$

Keeping the interference from other satellites below a certain value will put severe limits on the minimum diameter of the receiving earth station's antenna. Knowing the radiation patterns for the satellites and earth stations involved, one can calculate the interference level. The geometry is shown in figure 36.

In the near future, the interference from other satellites may be the critical factor for the design of earth station antennas. This is already the case for certain positions in the geostationary arc over Europe.

## 8 Satellite networks

The simplest form of satellite networks is the point-to-point or point-to-multipoint configuration shown in figure 37a) and b). So far, we have only considered these cases. However, there is often a need for several earth

stations to be interconnected through the same transponder, multipoint-to-multipoint, shown in figure 37c). The methods for allowing several users to utilise the same transponder are called multiple access techniques. The transponder is a resource which can be characterised by its available power and bandwidth. Efficient use of this common resource is a very important problem in satellite communication. The channels are designed to the users either fixed (pre-assigned) or on demand (demand assignments).

There are basically three methods of multiple access:

- Frequency Division Multiple Access (FDMA)
- Time Division Multiple Access (TDMA)
- Code Division Multiple Access (CDMA).

Random Access (RA) may also be utilised.

In FDMA, each user is permanently allocated a certain frequency band, out of the total bandwidth of the transponder, figure 38a). To reduce the adjacent channel interference, it is necessary to have guard bands between the sub-bands. Frequency drifts of the satellite's and earth station's frequency converters have also to be taken into consideration. FDMA is the traditional technique due to its simple implementation. However, due to the non-linear characteristics of the transponder, figure 29, a certain back-off of the TWT is necessary for multicarrier operation, in order to control the intermodulation products. This reduces the total transponder capacity.

In TDMA all stations use the same carrier frequency, but they are only allowed to transmit in short non-overlapping time slots, figure 38b). Thus, the intermodulation products due to the non-linear transponder are avoided. This means that the high power amplifier in the transponder can be operated near saturation. Accordingly, both the total transponder power and bandwidth are available. However, the TDMA technique obviously requires time synchronisation and buffer storage. This leads to rather complex earth stations.

In CDMA all users occupy the total transponder bandwidth all the time.

The users can be separated because each channel is multiplied by a unique spreading code. The composite signal is then modulated onto a carrier. The information is recovered by multiplying the demodulated signal with the same spreading code. The receiving earth station is accordingly able to recover the transmitted message by a specific user. No frequency or time coordination is needed before accessing the transponder. New users can easily be included. CDMA signals are resistant to interfering signals. This property can be utilised in systems with very small aperture terminals (VSAT), where interference may be received from adjacent satellites. The main disadvantages are cost and complexity of the receivers.

## 9 Literature

- 1 Berlin, P. *The geostationary applications satellite*, Cambridge University Press, 1988.
- 2 Maral, G, Bousquet, M. *Satellite communications systems*, John Wiley & Sons, 1986.
- 3 Ha, T T. *Digital satellite communications*, Macmillan Publishing Co., 1986.
- 4 Evans, B G. *Satellite communication systems*, Peter Peregrinus Ltd., 2nd edition, 1991.
- 5 Pratt, T, Bostian, C W. *Satellite communications*, John Wiley & Sons, 1986.
- 6 Dagleish, D I. *An introduction to satellite communications*, Peter Peregrinus Ltd., 1989.
- 7 Feher, K. *Digital communications. Satellite/earth station engineering*, Prentice-Hall Inc., 1983.
- 8 ITU/CCIR. *Handbook of satellite communications*, ITU, Geneva, 1988.
- 9 Stette, G. *Forelesninger i satellitt-kommunikasjon*, NTH.
- 10 Gutteberg, O, Lundstrøm, L-I, Andersson, L. *Satellittfjernsyn*, Universitetsforlaget, 1986.
- 11 Gagliardi, R G. *Satellite communications*, Van Nostrand Reinhold, 2nd edition, 1991.

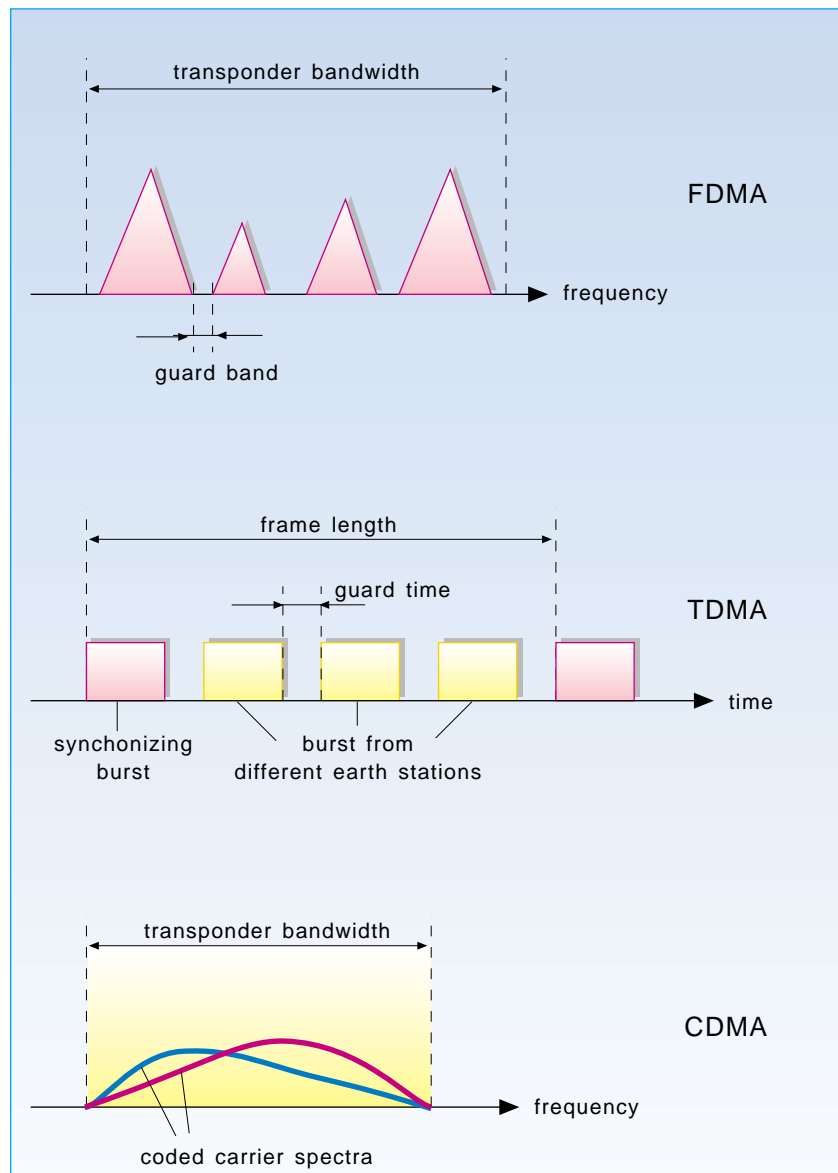


Figure 38 a), b) and c) Basic multiple access methods

# Satellite communications standardisation in Europe

BY GUNNAR STETTE

621.396.946(4)  
006

## The role of ETSI

Telecommunications is by nature an internationally oriented activity, and there has always been a strong requirement for international standardisation. For these purposes some very successful organisations were created, CCITT, Comité Consultatif des Télégraphes et Téléphones, CCIR, Comité Consultatif des Radios and ITU, The International Telecommunications Union, which forms a part of the United Nations system.

The organisations mentioned above are global. In addition, a European organisation was created for post and telecommunications matters, CEPT, Conférence Européenne des Postes et Télégraphes. Membership of this organisation was limited to the national Telecommunications Operators, the TOs.

CEPT carried out standardisation work in many fields, from postal stamps to the pan-European cellular mobile telephone system, GSM, which was named after a special group of CEPT, Groupe Spécial Mobile. Neither manufacturers nor telecommunications users were accepted as members of this organisation.

With the introduction of data systems connected to the telecommunications systems it was impossible to keep all telecommunications activities within monopolies. The national networks are in most countries still entrusted national monopolies, whereas special networks, terminal equipment and services were opened up to competition.

There were now many new players in the field, and these also wanted to have a voice in much of the activities that were carried out by CEPT. CEC, the Council of the European Community, was not too satisfied with this state of affairs.

During a fact-finding mission on telecommunications to the United States in 1986 it became apparent that telecommunications standards making in Europe had to be substantially reinforced. In 1987 the CEC published its Green Paper Telecommunications. In it was floated the idea that a European Telecommunications Standards Institute (ETSI) had to be created. ETSI should have participation from many categories, operators, manufacturers, users, and regulators. In May 1988 the ETSI General Assembly met for the

first time, and in July 1988 the first meeting of the Technical Assembly was held.

## The structure of ETSI

The main product of ETSI is telecommunications standards. In addition, where the technology is not mature or stable, and where the need for, or structure of, a standard is not clear, the issue may be studied by the bodies of ETSI. In this case the output of the work is an ETR, ETSI Technical Report.

Most of the standardisation work is carried out in one of the twelve Technical Committees, TCs, and in the Technical Sub Committees, STCs. The TCs are as follows:

NA	Network Aspects
BT	Business Telecommunications
SPS	Signalling, Protocols and Switching
TM	Transmission and multiplexing
TE	Terminal Equipment
EE	Equipment Engineering
RES	Radio Equipment and Systems
SMG	Special Mobile Group
PS	Paging Systems
SES	Satellite Earth Stations
ATM	Advanced Testing Methods
HF	Human Factors

The basis for the work is contributions from the members of the committees, but this is not always sufficient. There are also provisions to establish a project team (PT) to develop a basic document for further processing in the committee system. The PTs can be paid by ETSI or by external organisations, mostly the CEC and EFTA, the European Free Trade Association.

A PT will usually consist of a small number of members, typically two to three, who work concentrated on a defined Terms of Reference at the ETSI Headquarters in Sophia Antipolis near Nice.

## The structure of ETSs

An ETS (European Telecommunications Standard) will normally contain both *requirements* and *recommendations*. Typically, for a TVRO terminal the *requirements* should deal with protec-

tion of the environment and cover elements such as:

- mechanical protection of personnel
- electrical safety
- electromagnetic compatibility, i.e. protection of other radio services (terrestrial and satellite), including EM power emitted by power supply, local oscillator leakage and other spurious sources.

*Recommendations* could cover elements which deal with quality

- antenna gain receive patterns
- receive polarisation discrimination
- antenna mechanical capability (pointing, polarisation, etc.).

Non-compliance with the recommendations will not entail refusal of the type approval.

## The production process for an ETS

The preparation of a standard can be a very large project. The work is basically done within the STCs, where all ETSI members have the opportunity to be represented. It is further based on voluntary contributions from the participants.

The production process up to an approved European Telecommunications Standard is defined in the Rules of Procedures of ETSI. The Draft ETS will be prepared (if necessary by a PT), discussed and agreed in the relevant STC, and then submitted for approval by the TC.

The main steps for the further approval process according to the Normal Procedure is as follows:

- *Public Enquiry*. This will last for anything from 17 to 21 weeks. Each ETSI member will then have the opportunity to express their views on the proposed standard.
- *TC Review*. The TC will receive the comments from the Public Enquiry, together with the comments from the Standards Management Department of the ETSI Secretariat. There are procedures for resolving disagreements among the members of the TC, but it is important to note that the whole work of ETSI is based on consensus. Consensus is here defined as the absence of sus-

tained resistance. If consensus cannot be reached, the minority views shall be reported to the Technical Assembly.

- *Voting.* The document, as prepared after the Public Enquiry, is then sent out for Voting. It is to be noted that whereas each ETSI member will have the opportunity to express their views during the Public Enquiry, for the Voting process there is only one vote per country. The vote of each country is weighed as decided by the General Assembly.

The results of the Voting process is sent to the National Standards Organisations, to all the ETSI members and to the relevant TCs and STCs.

There is also a Unified Approval Procedure and an Accelerated Unified Approval Procedure, which can be applied under special circumstances.

## ETSS and CTRs

ETSS are standards, and as such voluntary. In the European context we have a different type of document, *CTR, Common Technical Regulations*. These are mandatory requirements that have to be met for equipment to be operated within the EC and EFTA countries.

CTRs are often derived from ETSS, but not all the components of an ETS are relevant for a CTR. At the same time there could also be other requirements not contained in the ETS that should be incorporated in the CTR.

The conversion process from ETS to CTR goes via a *Technical Basis for Regulations, TBR*, and ETSI is usually tasked to prepare the TBRs in the relevant fields.

As an example, the CEC is now considering TBRs and CTRs to be prepared for the satellite communications field. As a starting point ETSI has been requested to prepare an *ETR* on this subject.

## TC-SES Technical Committee Satellite Earth Stations

At the 4th Technical Assembly of ETSI in Nice, 29 - 30 March 1989, a Technical Committee on Satellite Earth Stations was set up. The basic mission of the new TC was to create European Telecommunications Standards ETSS

in the area defined by its terms of reference, in line with views expressed by the CEC in its "Green Paper on Satellite Communications":

- to allow significant improvements in the satellite communications development of Europe
- to offer new opportunities to the industry.

## Terms of reference and organisation

The TC-SES Terms of Reference, as approved by the ETSI 5th Technical Assembly, are as follows:

"The field includes:

- all types of satellite communication services and applications, including mobile
- all types of earth station equipment, especially as concerns Radio Frequency Interfaces and Networks
- protocols implemented in earth stations for exchange of information, for connection of network and/or user terminal equipment, control and monitoring functions."

The TC-SES is the "primary committee for co-ordinating the position of ETSI on the above aspects, vis-a-vis the standardisation of outside bodies, in particular of International Standardisation Organisations (CCIR, CCITT, IEC, etc.) and of the international satellite organisations (EUTELSAT, INTELSAT, INMARSAT)."

The TC-SES is organised in five Sub Technical Committees, STCs:

- SES1: General system requirements for European satellite networks and earth stations
- SES2: Radio Frequency (RF) and Intermediate Frequency (IF) equipment
- SES3: Earth Station application/network interfaces, and control and monitoring techniques
- SES4: Television and sound programme equipment
- SES5: Earth stations for mobile services

SES2 and SES3 are of "horizontal" nature, i.e. dealing with subjects grouped by their technology, whereas

SES1, SES4 and SES5 are of "vertical" nature, dealing with subjects grouped by types of services and/or their systems aspects.

## Relations with other organisations

TC-SES is participating actively in the work of CCIR, in particular Study Group 4 (Fixed Satellite Services) and Task Group TG 4/2, set to prepare recommendations on VSAT systems and earth stations.

There is a formalised co-operation between ETSI and the European Broadcasting Union (EBU) on the RF part of satellite broadcasting systems and equipment.

TC-SES is actively participating in the work of the new "Ad hoc CCIR/CCITT Experts Group on ISDN/Satellite Matters", which has been charged with the revision, on world-wide basis, of those CCITT recommendations which prove to be insufficiently compatible with the implementation of satellite links in the ISDN.

TC-SES is co-operating with CENELEC, the European Committee for Electrotechnical Standards, on TVRO terminals, the outdoor unit being the responsibility of ETSI.

## TC-SES Programma of Work

The TC-SES part of the present ETSI Programma of Work is given in the Annex. It will be noted that the standards are to a large extent based on a compatibility approach with the main emphasis on preventing interference between different systems.

The Work Programma Items DE/SES-2001 and DE/SES2002 have produced for Receive Only VSATs and for Transmit/Receive VSATs in the 11/14 GHz band as prETS 300 157 and prETS 300 158, respectively. These were approved by voting in 1992.

Draft standards for the C-band, DE/SES-2004 and DE/SES-2005, have been prepared and are ready for Public Enquiry.

A draft for the ETS for SNG (Satellite News Gathering) station, DE/SES-2003, has been prepared by a Project Team, and this is also ready for Public Enquiry.

Standards for control and monitoring of VSAT networks and VSATs, prETS 300 161 and prETS 300 160, were also approved by voting in 1992. The inter-connection issues are under preparation by a Project Team.

ETS for TVRO stations for the FSS band was prepared under DE/SES-4001 and is contained in prETS 300 158. A similar document for TVROs operating in the BSS band is ready for Voting.

There are two important continuing activities. One is to study and monitor radiation limits to/from earth station equipment. The other one is to monitor the compatibility of ISDN ETSS with satellite links.

As mentioned above, standards will be an important element in the preparation of TBRs, Technical Basis for Regulations. The CEC has issued a mandate to study and investigate in detail which parts of currently available standards in the satellite earth station equipment field match with the essential requirements of the draft Satellite Equipment Directive. The CTRs shall cover TVROs in FSS and BSS bands, data receive-only, VSAT two-way, and the mobile low data rate terminals, connected or not connected to the public telecommunications network. All the ETSS mentioned above will form a part of this study.

The output of this work, which is entrusted the TC SES, will be an ETR.

Another element of standardisation is test specifications. The creation of the European Single Market of telecommunications without technical barriers to trade implies harmonised European standards and a harmonised European testing and certification framework.

The certification authorities and the testing laboratories in Europe will not be capable of reaching their objectives if, among other things, European standards in the area of test specifications do not exist.

The CEC has therefore proposed that ETSI through TC SES develop ETS/ENs for test specifications of the ETSS mentioned above for the VSAT and TVRO field. The test specifications for VSAT are of global interest. In order to achieve world wide recognition of tests performed by different laboratories, the CEC has requested

that alignment of the European standards with the global standards currently under development in CCITT should be ensured.

## Case study: Low Earth Orbit (LEO) Communications Satellite Systems

There is a growing interest in the development and deployment of communications systems using satellites in Low Earth Orbits (LEO), in particular by the US industry. Also, WARC 92 has allocated new frequencies for mobile satellite systems, also for the systems using LEO satellites.

The WARC resolved to invite the organs of the ITU to carry out, as a matter of priority, technical, regulatory and operational studies to permit the establishment of standards governing the low orbit satellite systems so as to ensure equitable and standard conditions of access of all countries and to guarantee proper world-wide protection for existing services and systems in the telecommunication network.

The European Commission has also taken an interest in these systems. The CEC is concerned about the situation for European industry, operators and users in this area. Following a letter from the CEC to the Chairman of ETSI Technical Assembly on standards for such mobile communications systems, the TA decided that ETSI would produce an ETSI Technical Report on the matter. This report should try to set down all of the issues concerning standardisation, both technical, economical and any other factors.

The issue is now entrusted to TC SES, and it is being studied by a PT. The study should consider some of the problems raised by the use of the LEO systems as given below:

- comparative description of the different proposed systems
- the role of LEO systems in the future telecommunication systems (PCS, FPLMTS)
- protection of other satellite and terrestrial services
- network access issues and possibility of interworking with public networks

- compatibility with current terrestrial mobile networks, in particular with the GSM
- system aspects and network management issues- the need for European standards, and scope and extension of these standards.

## Future activities

ETSI, as a market oriented organisation, must constantly monitor the need for new standards within its field. The preparation of the work programme is done within the TCs, where the expertise and the contact with the market is present.

It is apparent from the TC-SES work plan given in the Annex that it focuses on the "environmental" aspects of standardisation, EMC considerations, etc. This approach was agreed at the early stages of the Committee's work. One question to be reopened is the possible need for standards which involve system design. A possible candidate would be an open 20/30 GHz VSAT standard for Europe, similar to the GSM standards for cellular systems.

Of increasing importance in the future will also be the work on EMC, and on compatibility between the ISDN standards and satellite links.



<b>List of ETSs under preparation: (As per September 1992)</b>	
DE/SES-2001	Ku-Band Receive only VSATs used for data distribution
DE/SES-2002	Ku-Band Transmit/Receive VSATs used for data communications
DE/SES-2003	Satellite News Gathering (SNG) Transportable Stations (14/11-GHz RF/IF Equipment)
DE/SES-2004	Satellite Earth Stations for data communication (C-Band Transmit/Receive VSATs RF/IF Equipment)
DE/SES-2005	Satellite Earth Stations for data communication (C-Band Transmit/Receive VSATs RF/IF Equipment)
DE/SES-3001	Satellite Earth Stations for data communication (C-Band Transmit/Receive VSATs RF/IF Equipment)
DE/SES-3002	The interconnection of Very Small Aperture Terminal (VSAT) systems to the Packet Switched Public Data Networks (PSPDNs)
DE/SES-3003	Standards for Interconnection of VSAT systems to C-SPSDNs
DE/SES-3004	Centralised control and monitoring functions for VSAT networks
DE/SES-3005	Control and monitoring function at a VSAT
DE/SES-3007	Standards for interconnection of VSAT systems to ISDN
DE/SES-4001	Standards for interconnection of VSAT systems to ISDN
DE/SES-4002	Transportable Earth Station for Satellite news gathering (general)
DE/SES-4003	ETS on TVRO Earth Stations in the BSS band
DE/SES-5001	Mobile earth stations operating in the 1.5/1.6 GHz bands providing low bit rate Data Communication under Land Mobile Satellite Service (LMSS) and Radio Determination Satellite Service (RDSS)
DE/SES-5002	Mobile earth stations operating in the 10/14 GHz bands providing low bit rate Data Communications under Land Mobile Satellite Service (LMSS)
DE/SES-5003	Mobile earth stations operating in the 1.5/1.6 GHz bands providing low bit rate Data Communications under Maritime Mobile Satellite Service
SI/SES-5-3	Mobile Earth Stations Operating in the 1.5/1.6 GHz Bands providing Voice and High Speed Data Communications under Land Mobile Satellite Service

# A review of Norwegian space activities

BY GEORG ROSENBERG

629.78(481)

## Abstract

Norway has been a full member of the European Space Agency (ESA) since 1987. This membership is used as an effective tool in strengthening and developing Norwegian industry as well as in covering Norwegian space science and user requirements. The Norwegian Space Centre has a key role in this process.

The Space Centre consists of three units:

- The head office in Oslo acting as a strategic unit in charge of plans and programmes
- Andøya Rocket Range and Tromsø Satellite Station working as operational units with main emphasis in the space science and earth observation areas, respectively.

Six basic activity areas have been identified:

- Space science, following up and extending Norwegian traditions in cosmic geophysics and astrophysics through participation in ESA's science programme and through the use of sounding rockets and balloons.
- Ground infrastructure, such as Andøya Rocket Range and Tromsø Satellite Station, utilising Norway's northern location and other advantages. Facilities in the Svalbard area could be of importance in the future.
- Satellite Communications is mainly commercial and is by far the largest sector with a large contribution of Inmarsat related products and services.
- Satellite navigation and related services in particular based on differential GPS, are also commercialised and are growing rapidly.
- Earth observation with emphasis on near real time services based on radar observations, particularly SAR, is being developed for maritime surveillance and environmental monitoring. The launch and operation of ERS-1 has been an important step in this direction.
- Industrial development based on ESA's programmes for space transportation and space station and with spin-offs to the marine and offshore sectors.

The total turnover of space related products and services from these areas in Norway is growing rapidly and reached a total of USD 290 M in 1992.

## Introduction

Norway draws greater benefits from its space activities than most other countries. Our geography as well as our maritime activities imply that we have extensive requirements for communication, navigation and earth observation services. These requirements are being met to an increasing extent by satellite-based systems. Satellites are also essential in meeting the demand for comprehensive monitoring of the global environment.

These user requirements encourage the development and manufacture of high-technology products and services. For this reason, our national efforts in space activities are of vital importance. Such efforts will enable us to exploit the results for industrial growth and development of the national infrastructure, and thus help us to fulfil national goals for economic growth and employment. These activities are also of decisive importance for our space research, and they are important means of serving our foreign policy interests.

Norway's efforts in space are thus based on user oriented, scientific, industrial and political considerations.

The main objectives for Norwegian space activities by the year 2000 are to establish:

- Norwegian industry and other space-based business, with an average rate of growth in national and international markets of at least 15 % per annum
- A leading international position in those industrial areas that have been given priority
- Considerable industrial growth in new areas, based on public-sector R&D efforts in space activities
- Cost-effective space-based systems that meet national user requirements
- A leading international position in those areas of basic science that have been given priority
- A leading European position in those aspects of ground infrastructure for which we have natural geographical or other advantages.

## Funding, general strategies and main priorities

These national objectives have been established by the Norwegian Space Centre which has a key responsibility

in initiating, supporting and co-ordinating space projects and programmes. Around 55 % of the USD 60 M public sector funding of Norwegian space activities in 1992 is over the Space Centre budget, figure 1. In particular our participation in the European Space Agency (ESA), represents a major part of our space programme.

The Space Centre responsibilities include:

- Preparing long term plans for Norwegian space activities
- Contributing to the development, co-ordination and evaluation of Norwegian Space activities
- Planning, funding and following up Norwegian participation in ESA programmes
- Planning, funding and following up national programmes for the development of industrial products, services and capabilities, for bilateral co-operation and for the development of applications of earth observation
- Supporting and operating the Andøya Rocket Range and the Tromsø Satellite Station.

Close, committing co-operation between Norwegian industry, users and research institutions is an essential means of meeting our national objectives. In addition, concentration on particular fields, projects and participating organisations is essential.

Space activities are of international character, and it is vital that we utilise our status as member of international organisations in order to obtain the desired results. The most important of these organisations are INMARSAT, INTELSAT, COSPAS/SARSAT, EUTELSAT and EUMETSAT. Norwegian membership in the European Space Agency, ESA, is of special importance in this respect, as it offers Norwegian companies the opportunity to participate in the European scientific, technological and industrial network, thus promoting internationalisation of Norwegian research and industry.

Space activities, by nature, have a long-term time-scale, but there are also opportunities for considerable gain on a short-term basis. The areas in which Norway has obtained remarkable results internationally, have to a great extent been based on our national conditions and requirements, confirming the cluster theory which was put forward by professor Michael Porter in his book "The Competitive Advantage of Nations".

In addition to space science five main sectors for the development of industry and services have been selected, giving altogether six main areas of activity.

These areas are:

- Basic research in space science
- Ground infrastructure services for which we have natural advantages, and derived products
- Telecommunications services, and derived products
- Navigation and positioning services, and derived products
- Earth observation services, and derived products
- Industrial development based on ESA's space transport, space station and science programmes.

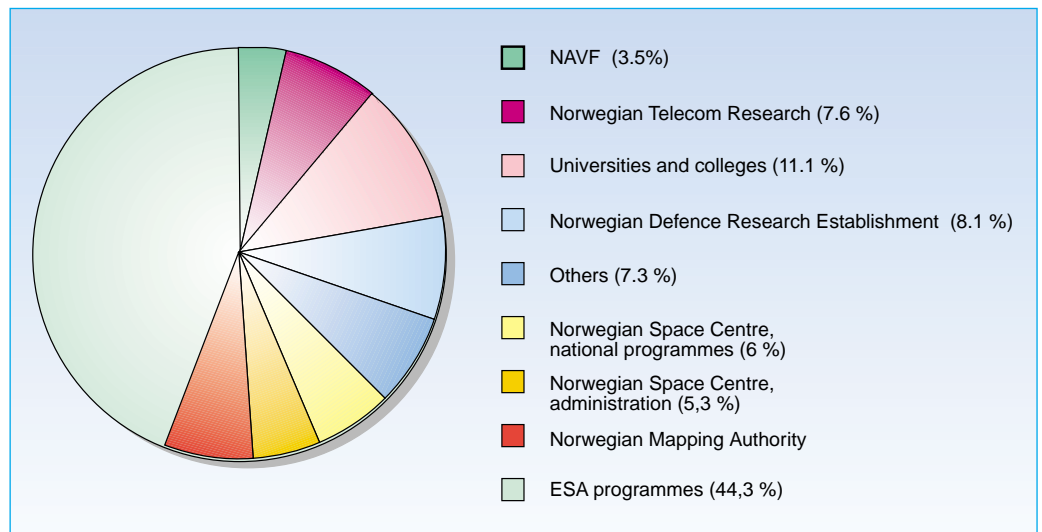


Figure 1 Public sector funding of space R&D activities: distribution in per cent (1992) of a total of USD 60 M

## Space science

The science research council, NAVF, is basically responsible for funding national space science projects while the Norwegian Space Centre is responsible for our ESA contribution.

Norwegian space science strategies are to

- Utilise the opportunities provided by the ESA programmes
- Continue the use of Andøya Rocket Range for national and co-operative projects
- Develop bi- and multilateral projects in areas where the previous points do not meet the scientific requirements.

The priorities are:

- Space physics with emphasis on magnetospheric studies and upper atmosphere dynamics
- Astrophysics with emphasis on studies of dynamical phenomena in solar and stellar atmospheres
- Life science with emphasis on plant physiology.

Main projects are:

- Participation in eight experiments on ESA's SOHO and Cluster satellites, five with hardware
- Pulsating auroral (PULSAUR) and middle atmosphere (TURBO, RONALD) rocket projects

- Auroral Imaging Observatory (AURIO) for ESA's POEM programme. This is the largest space science project with Norwegian leadership
- Participation in NASA's Gravity Threshold experiment (GTHRES) on IML-1 flown in January 1992.

## Andøya Rocket Range

The Andøya Rocket Range is an operational unit under the Norwegian Space Centre.

As a consequence of its advantageous geographical location and modern, highly specialised infrastructure, Andøya Rocket Range is able to offer Norwegian and overseas organisations services for space science and related activities. These advantages have traditionally been of particular relevance for auroral research, but will in the future also be important for ozone research and for measurements of other environmental parameters.

Andøya Rocket Range is being developed on a commercial basis within existing as well as new areas of activity. An important aspect of this process of development is the construction of a new universal launcher which will enable larger rockets up to 20 tons to be launched. The possibility of establishing a base for launching small satellites is under study.

The recently added benefit of payload recovery from the Norwegian Sea is a useful and cost-effective service for many scientific programmes.

An Arctic Lidar Observatory (ALOMAR) for middle atmospheric research is being planned in close proximity to the rocket range. ALOMAR will provide a wealth of new information on the dynamics of the middle and upper atmosphere in the 10 to 100 km range.

Together with the EISCAT radar system which now is being enhanced with a Svalbard facility, this gives a powerful set of tools for space science.

## Earth observation

The Norwegian Space Centre is the driving force in developing the field of earth observation. The main objective is to develop operational services with emphasis on near real time marine applications. This implies securing Norwegian users access to data and developing industry and ground infrastructure that can deliver products and services for satellites, operators and users. The strategy to achieve these objectives is based on

- Participation in ESA programmes
- Complementary bilateral arrangements
- Developing Tromsø Satellite Station and associated infrastructure
- Application programmes developing value adding industry
- Demonstration projects with user commitment.

Emphasis is placed on radar and other microwave based sensors, in particular SAR. Norway therefore participates in ESA's ERS-1 and ERS-2 programmes and has announced its participation in the POEM-1 programme. Norway will also be ESA's source of J-ERS SAR-images and is discussing arrangements for acquiring RADARSAT and Seastar data.

The main applications under development are:

- Ice mapping, monitoring and forecasting
- Ship detection and surveillance
- Oil spill detection and monitoring
- Ocean surface structure monitoring

- Wind and wave input to meteorological models
- Ocean pollution and biomass production monitoring.

The geographical areas of interest are primarily those limited by the area covered from the Tromsø Satellite Station with emphasis on the coastal zone and the marginal ice zone of the Arctic. A very interesting prospect for the future is the real time use of SAR imagery for navigation through the North East Passage between the Barents Sea and the Bering Strait which would assist operating the shortest shipping route between Europe and Japan.

A number of Norwegian research institutes and companies are taking part in these activities delivering products and services and have brought Norway in the forefront in the development of near real time applications for operational purposes.

## Tromsø Satellite Station

Tromsø Satellite Station became an operational unit of the Norwegian Space Centre on 1st January 1991 and is being developed to operate on a commercial basis.

The station is suitably located for receiving data from satellites in polar orbit seeing 10 out of 14 passes per day and is in this respect only surpassed by a possible Svalbard facility which would see all passes.

A strategically important business area for the satellite station is therefore long-term contracts for operational services with national and international institutions and satellite operators like ESA.

As pointed out in the previous section, Tromsø Satellite Station is also an important element in our earth observation strategy. Another area of concentration is therefore near real-time processing and distribution of data for operational services, such as monitoring ocean and weather conditions, natural resources, maritime traffic and ice conditions.

A key element in this system is the very fast and powerful digital programmable SAR processor, CESAR, which has been delivered by Norwegian industry for the ERS-1 SAR processing system. A second unit has been ordered for the J-ERS-1 processing and

new and substantially faster models are under development, table 1.

Completing the system is the satellite based IDUN distribution system which allows the user near real-time access to the processed information, figure 2.

## Telecommunications

The Norwegian Telecom has played a leading role in developing satellite communications in Norway with the Norwegian Space Centre responsible for our ESA participation.

Measured in terms of turnover this is by far the most important sector of space activity. Due to a very early start in maritime communications, Norway ranks number two in INMARSAT and Norwegian industry has around a 20 % share of the world market for INMARSAT ground stations and mobile terminals. This is a purely commercial market which is expected to grow rapidly as a result of the recent introduction of aeromobile and data transmission services and due to the new standards B & M which is being introduced in the near future.

In the business communications area Norway opened NORSAT-A in 1976 as the first domestic satellite communication system in Europe serving our offshore installations in the North Sea and our northernmost communities in Svalbard at 78° N. This has been followed by NORSAT-B, a meshed type, 2 Mbit/sec, roof top, multipurpose communication system which now also is being offered on the European market. A new concept for a low data rate and low cost, VSAT-type system which has been developed on an ESA contract, was demonstrated last year. The marketing of both these systems will benefit from the increasing deregulation in Europe.

In the TV distribution field various MAC standards have been implemented and tested and equipment is being offered by Norwegian industry.

On the space segment Norwegian interests have concentrated on surface acoustic wave (SAW) based signal processing devices and industry has been space qualified through participation in ESA programmes. This particular capability has also resulted in the delivery of the chirp generators for the radar altimeters on the ERS-1 & 2 satellites.

## Navigation

The American Global Positioning System will be fully operational from 1993. However, the 100 m accuracy offered to civilian users is unsatisfactory for many purposes.

Differential GPS equipment giving navigation accuracies down to 5 m has been developed and DGPS services are being offered on a commercial basis along the Norwegian coast and in the adjacent ocean areas.

In addition to this the Norwegian Mapping Authority last year installed a complete 11 station DGPS system that will provide necessary accuracy for offshore and land surveying and for fast traffic navigation in the air and along the coast.

The Mapping Authority has also begun the construction of a geodetic laboratory with a VLBI station at Svalbard. As part of a global network this station will contribute in general to solid earth research and in particular to the global change programme.

## Space Station and Space Transportation

The main objective for Norwegian participation in the Space Station and Space Transportation programmes is to develop new products, services and markets for Norwegian industry and to secure Norwegian participation in the future exploitation of space. In the Ariane-5 programme Norwegian industry is developing and supplying electronic parts as well as mechanical subsystems such as the booster attachment and separation system and the booster separation rockets.

In the Columbus programme main emphasis has been on verification, integration and checkout systems, logistics and quality assurance/product assurance services. These are all areas which benefit from spin-offs to and from Norwegian offshore industry.

Astronauts have not been a Norwegian priority. Nevertheless, a Norwegian candidate was a runner up in the final ESA selection.

## Conclusion

Norway is a small country with only 4.2 million inhabitants but with location, geography and business areas

Generation	1	3	5
Status	Tromsø Satellite Station ERS-1 SAR processor Delivered: mid 1991	Tromsø Satellite Station J-ERS-1 SAR processor Delivered: ultimo 1992	Under development Real time SAR processor In production: 1995
Multi Arithmetic Logic Units	4	1 (- 8)	1, 2, ... > 10
Performance	320 M flops	80 (- 640) M flops	5, 10, ... > 50 G flops
Processing time 100 km x 100 km full resolution	7 min 55 sec	30 min (- 2 min)	< 30, < 15, ... < 3 sec
Size	Cabinet	Work Station	Desk Top

Table 1 Cesar SAR Processor Description

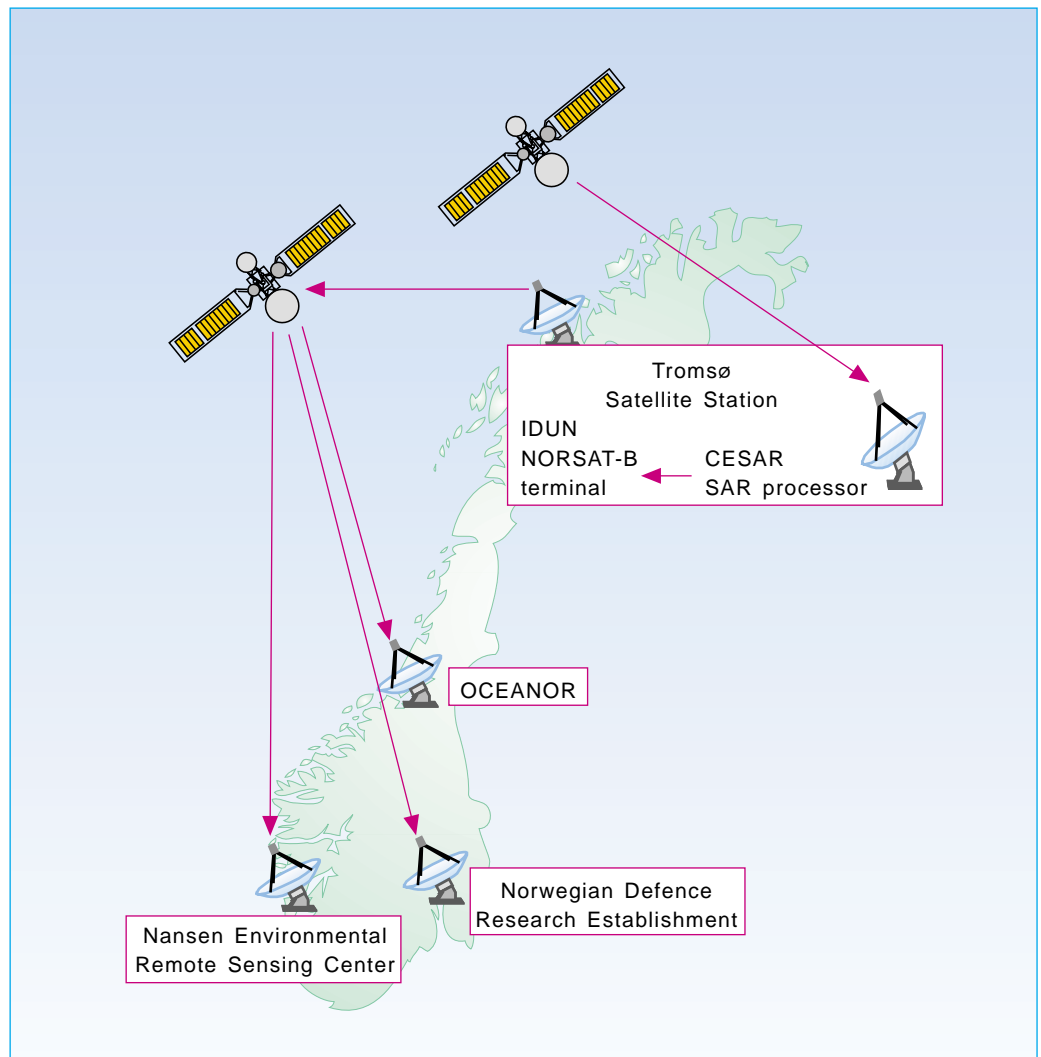


Figure 2 The Norwegian fast delivery SAR image distribution system

that benefit from space activities. This can be seen from the total turnover of space related products and services which have shown a continuous and substantial growth over the past 5 years and in 1991 reached a total of USD 290 M, figure 3.

By their very nature space activities are global. Norway's relatively high participation in space related activities therefore makes us more globally oriented at a time in history where we all must learn how to co-operate better. We consider this to be an advantage and based on our past success we look to the future with controlled optimism.

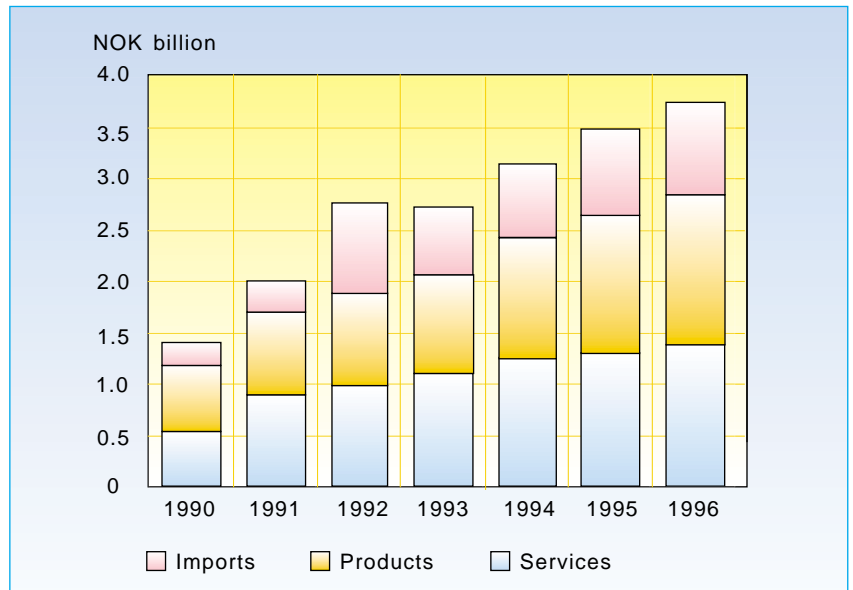


Figure 3 Total turnover of space-related products and services in Norway (calculated figures and prognoses)

# TSAT - a low-cost satellite communication network

BY TERJE PETTERSEN AND PETTER CHR AMUNDSEN

621.396.946

## Abstract

A closed satellite communication network designed specifically for low data rate communication (300 - 9,600 bps) at Ku-band is described. The low data rate design of the TSAT system allows the transponder load and power consumption to be scaled in proportion with the data rate, resulting in an optimised utilisation of the geostationary orbit. Solutions to the normal problem areas in communication at low data rates (frequency drift, phase noise and interference) are described. A cost/performance comparison between traditional VSAT systems and the TSAT system is given, together with a technical description of the TSAT system.

## 1 Introduction

The Very Small Aperture Terminal (VSAT) systems have over the last years developed rapidly within satellite communication. Together with various global systems for mobile communication, this development has made satellites an attractive medium to a large number of users, based on cost/performance advantages.

Current VSAT systems are normally only cost-effective for large networks with a high utilisation of the available channel capacity, since the necessary investments and operational costs are quite significant. Current VSAT technology sets a lower limit on the offered data rate. Reducing the system cost, and offering data rates tailored to the users' requirements are key issues in developing satellite communication systems to a broader range of applications. These systems are expected to introduce satellite communication to a large number of new users, removing the image of satellite communication as exotic and expensive solutions to "ordinary" communication needs.

Environmental, ecological and security surveillance and process control and monitoring, are typical examples of applications with requirements that are not solved in an optimised way by today's VSAT systems. The transmission data rate demand is in most cases as low as some few hundred bits per second, and the main traffic direction is from the Remote Terminals to the Hub Station. In order to make such systems economically attractive to the user, and to represent an optimised utilisation of the geostationary orbit, some main demands should be fulfilled: small and low cost earth stations, low power consumption, and low satellite transponder load with respect to bandwidth and power.

A straightforward down-scaling of today's VSAT systems with respect to antenna sizes, power amplifiers and bandwidth reduction, is not possible due to three main problem areas inherent in the satellite link: frequency

drift, phase noise, and interference requirements not met by small conventional antennas. The difficulties arising from these problem areas is discussed in section 4, together with general solutions to these problem areas. How these problem areas have been solved in the TSAT (Telemetry and data transfer via SATellite) system, which is under development by the Norwegian company Normarc a/s (1)-(5) is discussed in section 5.

## 2 Main TSAT features and applications

TSAT is a low-cost full duplex closed star network, dedicated to low-rate data transfer via satellite. Flexible interface options allow solutions to most low-rate data collection demands. An arbitrary number of Remote Terminals are controlled by one common Hub Station.

The TSAT design allows a Hub comparable in size and complexity to traditional VSATs (Very Small Aperture Terminals). Together with the low-cost Remote Terminals, TSAT requires low investments in earth station equipment. The efficient utilisation of satellite power and bandwidth results in very low operational costs. In figure 1 the following features can be observed:

- *Low data rate:* For 300 to 1 200 bps, Trellis encoded 4 FSK is used. Above 2 400 bps, BPSK with Forward Error Correction will be used.
- *Small earth stations:* The Hub Station, with an antenna diameter of 1.2 or 1.8 m is comparable in size to the Remote Terminals in traditional VSAT systems, while the TSAT Remote Terminal antennas are as small as 55 or 90 cm in diameter (figure 2).

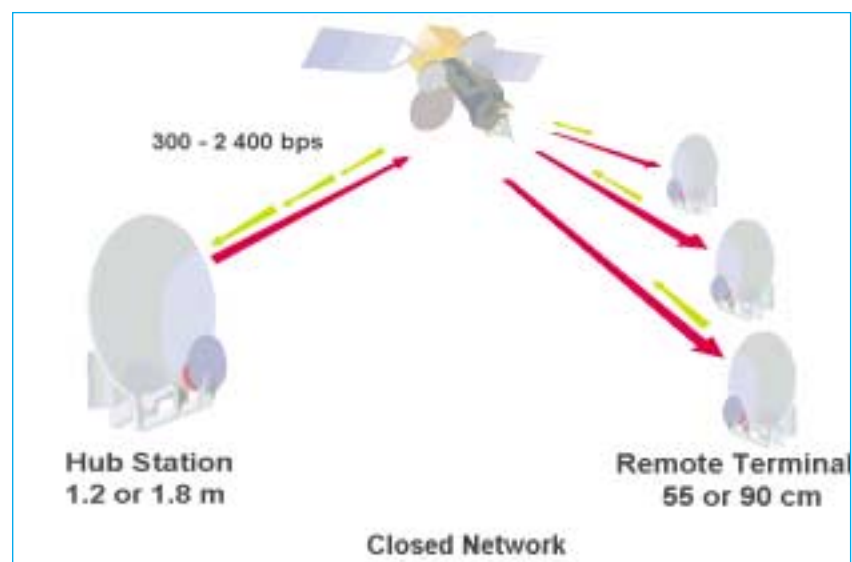


Figure 1 Closed TSAT network. The figure highlights the main characteristics of the TSAT system:

- low data rates (300 - 2,400 bps)
- small antennas (RT dia. 55 or 90 cm, Hub dia 1.2 or 1.8 m)
- Hub controls the network via the outbound link
- Remote Terminals share one or several inbound links
- any Ku-band communication transponder can be used
- operates independently of any other system

- *The outbound link*, indicated by the solid arrows, is running continuously, addressing and commanding the Remote Terminals.
- *The Remote Terminals* share one or several inbound channels in a Time Division Multiplexed mode, either in a polled sequence or by random access. The Hub Station has the ability to receive several inbound carriers, in parallel, allowing a single Remote Terminal, or a small group of Remote Terminals, to use one dedicated carrier if necessary.
- *Any conventional Ku-band communication transponder* can be used.
- *Closed network*, since the system can be dedicated to one single user, and this user does not have to pay for, or worry about, other control or command earth stations.

Possible applications include:

- General remote instrument control and data collection
- Collection and distribution of data for environmental, ecological and security surveillance
- Remote process monitoring and control.

### 3 Low data rate satellite communication systems

The following section will identify application areas requiring low data rate communication. In section 3.2 and 3.3 we discuss the current low data rate satellite communication system INMARSAT-C and the Spread Spectrum Systems, before comparing current VSAT systems with the proposed low data rate concept such as the TSAT system.

#### 3.1 Applications

Current VSAT systems are unable to offer cost-effective solutions in many applications that require low data rate communication. These applications include SCADA (Supervisory Control And Data Acquisition) applications such as:

- Surveillance, e.g. environmental, ecological, or security
- Data collection of e.g. meteorological, geomechanical, or seismological data
- Process or system monitoring and control, e.g. hydropower, oil and gas industry
- Road traffic control.

The predominant traffic direction for these applications is from the Remote Terminals to the Hub Station, where the data can be stored or distributed. Transmission of control data to the Remote Terminal is normally also required.

These applications are characterised by:

- Few characters per message (status reporting, measurement values)
- Relaxed response time requirements (10 sec. to a few hours)
- Often static low data rate traffic, dominated by traffic from the Remote Terminals to the Hub Station.

Other potential applications with low data rates include:

- Low-rate data broadcasting, with continuous monitoring of the remote terminals
- General low data rate communication, such as telex, telefax etc. in areas with poorly developed infrastructure
- Transaction oriented applications at low data rates, e.g. credit card verification, Automatic Teller Machine.

The communication demands for many data collection applications can be satisfied by the use of satellite networks with data rates in the range 300 - 1,200 bps. Networks for these applications may range from large systems covering a whole continent, to systems with a few Remote Terminals. Current VSAT systems offer a capacity much higher than this, leading to unnecessary, and often unacceptable, investments and operational costs.

In order to make satellite communication systems cost-effective and attractive for most low data rate applications, some main demands must be fulfilled:

- Small and low cost earth stations
- Low satellite transponder load with respect to bandwidth and power, i.e. an optimised utilisation of the geostationary orbit
- Low power consumption, allowing battery operation
- Operation under severe environmental conditions.

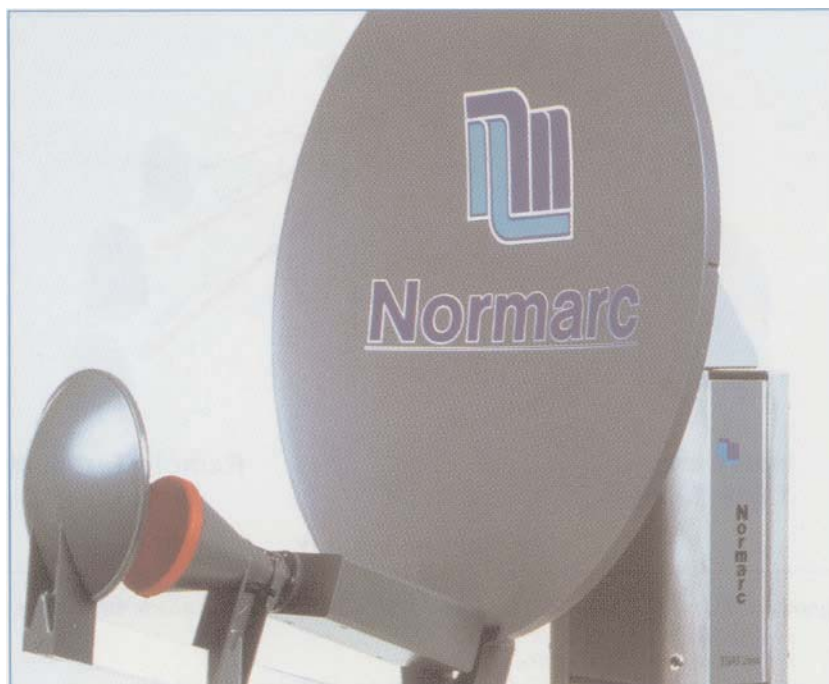


Figure 2 TSAT Remote Terminal, consisting of:

- antenna (55 cm dia. shown, 90 cm optional)
- RF Front End between antenna and horn
- Main Unit integrated with mounting structure



Before comparing traditional VSAT systems to low data rate systems, some comments will be given regarding existing global systems operating at low data rates, using INMARSAT-C as an example, and we also make some comments on the Spread Spectrum systems which traditionally have offered solutions to the problem areas related with low data rate satellite communication.

### 3.2 INMARSAT-C

INMARSAT-C is a global mobile communication system operating at L-band, offering data communication at 600 bps. The INMARSAT-C terminals are relatively low-cost, and can often withstand severe weather conditions. However, the INMARSAT-C concept as a global system requires the use of complex control stations leading to a relatively expensive data transmission. A dedicated VSAT low data rate network can therefore compete cost-effectively even at low traffic levels.

### 3.3 Spread spectrum systems

Spread spectrum techniques allow simple solutions to the problem areas for low data rate satellite communication mentioned above (6). In these systems, the data is spread over a large frequency band with a low power density. The total transmitted and received power is, however, approximately the same as in conventional modulation schemes. Some current low data rate VSAT systems utilising spread spectrum with code division multiple access (CDMA) have been developed, such as Qualcomm's "Omnitrack", and the eSAT system which is under development by Schrack, Austria and Space Engineering, Italy.

Spread spectrum systems can be cost-effective for a large number of Remote Terminals with a relatively high utilisation of the available network capacity. An optimum use of the geostationary orbit for medium and small systems is impossible, due to the extensive use of bandwidth inherently required by spread spectrum techniques.

### 3.4 Comparison between traditional VSATs and TSAT

In table 1, some main characteristics for an optimised low data rate collection system such as the TSAT system, are compared with a traditional VSAT data distribution star network. A con-

ventional Ku-band satellite transponder is assumed.

In traditional VSAT systems, the predominant message direction is from the Hub to the RT. The transponder load for the outbound link is therefore significant due to the high data rate and the relatively small RT antenna diameter. This implies that a large numbers of VSATs must share the same outbound carrier, in order to bring the space segment cost down to reasonable levels compared with the earth station costs. The low data rate system on the other hand, requires a very small fraction of the transponder capacity. With a small Hub, comparable to a traditional VSAT in size, complexity, and cost, a closed star network can be economical even for communication with a few distant sites.

The limiting channel for SCADA applications, however, is normally the

inbound link. Table 1 shows that the inbound link requires a small fraction of the power needed for the outbound link. The additional transponder load of a new inbound channel is not significant.

The use of several inbound frequencies will be a flexible, cost-effective way of increasing the network capacity. This feature also allows servicing the same traffic type with optimised protocols on dedicated frequencies, e.g. random access on one frequency and polling on another frequency.

The low data rates, and the possible flexibility in communication protocols, imply that cost-effective digital signal processors (DSPs) and microprocessors can be used, together with moderate complexity modem and data protocol software.

Typical Parameters	TSAT	VSAT
$E_b/N_0$ for BER $10^{-5}$	7 dB	7 dB
Rain & impl. margin	6 dB	6 dB
Hub antenna diameter	1.2 or 1.8 m	3 - 10 m
RT (VSAT) antenna diameter	55 or 90 cm	1.2 - 3 m
Data rate	0.3 - 2.4 kbps	9.6 - 512 kbps
Nature of traffic	Mostly static	Random
Main traffic dir.	RT → Hub	Hub → RT
<b>Transponder load example</b>		
Hub antenna diameter	1.2m	5 m
RT (VSAT) antenna diameter	55 cm	1.8 m
Data rate	300 bps	64 kbps
No of power limited carriers		
Hub → RT	5 000	240
RT → Hub	32 000	600
Relative transponder cost		
Hub → RT	5 %	100 %
RT → Hub	0.8 %	40 %

**Table 1** Comparison between TSAT and VSAT systems  
The table shows that the TSAT parameters are scaled proportionally to the data rate. The TSAT Hub size, complexity and cost is comparable to traditional VSAT terminals. The transponder cost is given relative to the VSAT system outbound link cost

## 4 Problem areas and solutions for low data rate satellite communication systems

There are three main problem areas to overcome in order to obtain low data rate systems with the performance sketched above:

- Frequency drift
- Phase noise
- Interference requirements.

### 4.1 Frequency drift

To obtain a minimum channel separation, the transmit frequencies must be stable. This will normally put requirements on the RTs' local oscillators which are not compatible with low-cost solutions. The implementation of compensation schemes to stabilise the transmitted frequency enables the use of low-cost oscillators.

### 4.2 Phase noise and modulation scheme

Coherent modulation schemes such as quadrature phase shift keying (QPSK), is extensively used in digital satellite communication. For very low data rate systems, coherent modulation methods should be avoided, due to the impact from system phase noise.

The relative phase noise versus carrier recovery loop bandwidth is shown in figure 3 (1), (5). The phase noise from a typical satellite, and the transmit/-receive chain, are integrated to give total phase noise, with the transmission data rate as parameter. Two phase noise contributions can be identified in figure 3:

- Phase fluctuations tracked by the loop. The contribution is inversely proportional to the loop bandwidth
- Additive thermal noise which contributes proportionally with the loop bandwidth.

For acceptable performance, the total phase error relative to the carrier should be below -15 dBc for binary phase shift keying (BPSK), and -25 dBc for quadrature phase shift keying (QPSK) (7). From figure 3 we see that for data rates below 2 400 bps, phase shift keying should be avoided. Various frequency shift keying techniques have been compared by DELAB, Norway, concluding with Trellis Coded 4 FSK as the best compromise between bandwidth, energy/bit and bit error rate requirements (4), (5).

### 4.3 Interference requirements - antenna performance

The ITU regulations and various space segment owners' requirements, restrict the allowable boresight and off

axis cross- and co-polar radiation density from earth station antennas. To avoid unacceptable interference into the VSAT channel from adjacent satellites, robust modulation and coding schemes, and antennas with low front-to side-lobe ratios, must be used. In traditional VSATs it is therefore recognised that for earth station antennas smaller than 1 metre in diameter at Ku-band, spread spectrum modulation is necessary. As discussed in section 3.3, spread spectrum solutions will only be cost-effective for large networks.

To achieve cost-effective low data rate systems, small low-cost antennas with satisfactory specifications must be used. Such antennas are already commercially available (see section 5.4.2.1).

## 5 The TSAT system

In this section, the TSAT system concept is further described, focusing on the central parts of the system design.

### 5.1 Transmission system

The basic functions in the Remote Terminal are shown in the simplified block diagram in figure 4. The converter chain design in the Hub transmission system is identical to the design in the Remote Terminal, with the exception of utilising a more stable reference oscillator ( $10^{-9}$ ). The unique properties of the TSAT transmission concept are:

- The reference oscillator in the Hub, with a stability of  $10^{-9}$ , is the frequency reference for the Hub and all RTs
- The Hub continuously transmits a carrier with modulated data that acts as a system pilot, frequency-locking the Remote Terminal transmission
- The use of a low-cost reference oscillator in the Remote Terminal (stability of  $10^{-5}$ ).

This low-cost concept ensures that the transmitted frequency stability complies with optimised transponder utilisation. The receive chain forms a frequency locked loop, and the transmit carrier is locked to the received carrier. The Hub Station detects and transmits the satellite frequency drift to the Remote Terminals, which correct the transmit synthesizers as

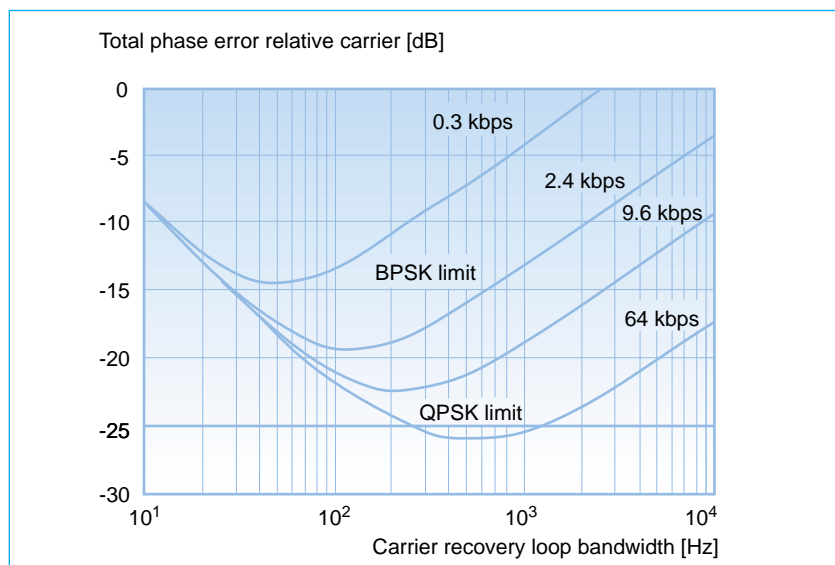


Figure 3 Relative phase noise versus carrier recovery loop bandwidth. The data rate is given as parameter. The acceptable phase noise levels for BPSK and QPSK are indicated, showing that coherent modulation should be avoided for data rates below 2,400 bps.

necessary, keeping the transmit frequency stable within a few Hertz.

The TSAT system offers the following modulation methods versus transmission data-rates:

- Trellis encoded 4 FSK for 300, 600 or 1 200 bps
- BPSK modulation (FEC optional) from 2 400 bps.

## 5.2 Satellite and geostationary orbit utilisation

The TSAT network can use any Ku-band communication transponder:

Up-link: 14.0 - 14.5 GHz

Down-link: 10.95 - 11.7 GHz or 12.5 - 12.75 GHz

The system fulfils ITU recommendations and satellite providers' requirements for fixed satellite services. Two examples of link budgets for the INTELSAT VA - F12, 241 MHz transponder and the EUTELSAT II-SMS transponder are given in table 2.

The output back-off (OBO) is as specified by the Norwegian Telecom for their intended use of an INTELSAT V transponder (1.8 dB), and by EUTELSAT for the SMS-transponder (4.2 dB). For the INTELSAT V - F12 satellite, the 46 dBW contour is used, giving a coverage area of Scandinavia with approximately 1 dB margin. For the EUTELSAT II satellite, the 44 dBW contour is used, giving a coverage area of Western Europe up to the northern parts of Norway and Sweden.

As can be seen from the table by comparing frequency bandwidth load and carrier power, the transponders are power limited. The power load is expressed by the ratio of the TSAT carrier to the total satellite power. One TSAT system uses only one outbound carrier, and a large number of Remote Terminals can share one or several inbound carriers. The annual satellite cost should therefore be negligible even for users with a very limited number of Remote Terminals.

## 5.3 Transmission system elements

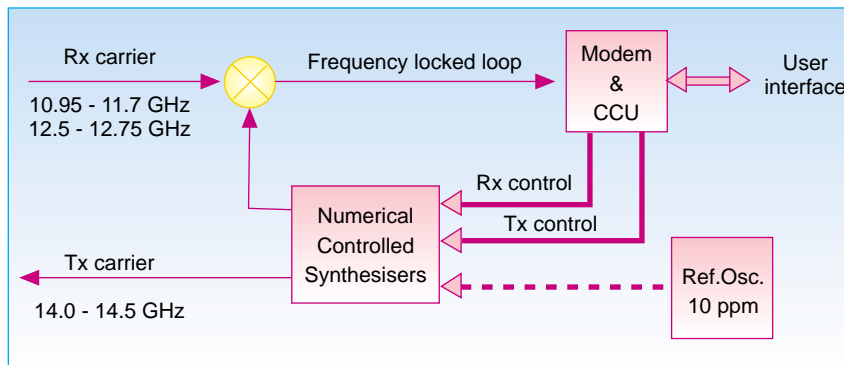
### 5.3.1 Introduction

The overall design criteria for the transmission system are:

- Low-cost Remote Terminal

Link budget for INTELSAT VA and EUTELSAT II-SMS				
<b>Common Parameters</b>				
	Hub station antenna	1.2 m		
	$E_b/N_o$	9 dB		
	BER	$10^{-8}$		
	Rain attenuation	0.5 dB 1% value		
	Pointing loss	0.5 dB		
	Implementation margin	1.5 dB		
<b>INTELSAT VA - F12</b>				
	Output back off	1.8 dB		
	Transponder bandwidth	241 MHz		
	RT/Hub location	46 dBW satellite EIRP contour		
Data Rate		300 bps		1200 bps
Channel separation		2 kHz		8 kHz
RT antenna	55 cm	90 cm	55 cm	90 cm
<i>Outbound link</i>				
EIRP, Hub	40 dBW	36 dBW	46 dBW	42 dBW
RF-power, Hub	26 dBm	21 dBm	32 dBm	28 dBm
No of power limited carriers	5 000	13 000	1 250	3 200
<i>Inbound link</i>				
EIRP, RT	32 dBW	32 dBW	38 dBW	38 dBW
RF-power, RT	24 dBm	20 dBm	30 dBm	26 dBm
No of power limited carriers	32 000	32 000	8 000	8 000
<b>EUTELSAT II - SMS</b>				
	Output back off	4.2 dB		
	Transponder bandwidth	36 MHz		
	RT/Hub location	44 dBW satellite EIRP contour		
Data Rate		300 bps		1200 bps
Channel separation		2 kHz		8 kHz
RT-antenna	55 cm	90 cm	55 cm	90 cm
<i>Outbound link</i>				
EIRP, Hub	41 dBW	37 dBW	47 dBW	43 dBW
RF-power, Hub	27 dBm	22 dBm	33 dBm	28 dBm
No of power limited carriers	2 800	7 200	700	1 800
<i>Inbound link</i>				
EIRP, RT	34 dBW	34 dBW	40 dBW	40 dBW
RF-power, RT	26 dBm	21 dBm	32 dBm	27 dBm
No of power limited carriers	15 400	15 400	3 900	3 900

**Table 2** Link budget for INTELSAT VA and EUTELSAT II-SMS  
The table shows that for the TSAT system, the transponders are power limited. A TSAT network utilizes only one outbound link, and therefore almost a negligible part of the transponder is used for each TSAT network, resulting in low operational costs



**Figure 4 TSAT Remote Terminal Concept**  
The transmitted frequency is frequency locked to the received frequency, enabling the use of low-cost local oscillators with a low stability (e.g. 10 ppm)

- Low satellite transponder load, giving low operational costs
- Reliable operation under all relevant operating conditions.

### 5.3.2 Remote Terminal

Low power consumption is a critical factor for applications in remote areas. The TSAT Remote Terminal is designed with this in mind. Three operational modes are offered, enabling the user to reduce the power consumption to an absolute minimum:

1 Transmit and receive	13 W
2 Receive	7 W
3 Sleep (pre-set wake-up)	0 W

Figure 5 shows a simplified block diagram for the Remote Terminal. The main modules are commented on below.

#### 5.3.2.1 Antenna

Figure 2 shows the Remote Terminal antenna, where the electronic equipment is integrated into the mechanical structure. The shown antenna has a 55 cm aperture diameter, but is also available with 90 cm diameter. The antenna is die cast in large quantities by Fibro-Støp, Norway for satellite TV

reception at Ku-band. The synthesizing procedure is developed at the Norwegian Telecom Research.

The antenna is of the off-set Dual Shaped Gregorian type. This construction principle allows the radiation pattern to be shaped with low side-lobe levels. Inherent in the synthesizing procedure is also the control on cross-polar levels. As opposed to most low-cost Ku-band antennas, these antennas have therefore the required performance for both reception and transmission, (8)-(10).

To protect the antenna and electric equipment in special severe environments (high mountain territories, exposed coastal areas etc.), a special enclosure with flexible antenna random canvas will be available.

#### 5.3.2.2 RF Front End

The integrated RF Front End consists of:

- OMT (Ortho Mode Transducer)
- HPC (High Power upConverter)
- LNC (Low Noise downConverter).

The OMT is combined with the RF Front End housing. The HPA RF power output is 1 Watt, utilising FET

transistors. The integration of mechanical and microwave design enables cost effective solutions.

#### 5.3.2.3 Main Unit

The design includes high-performance, low-cost digital Phased Lock Loop (PLL) circuits.

The modem is digitally implemented in a Digital Signal Processor (DSP). In the DSP, both carrier- and clock-recovery is performed, together with optimised filtering, adding/check of CRC and optimal FEC (Forward Error Correction). The modem software is developed by SINTEF DELAB, Norway (4).

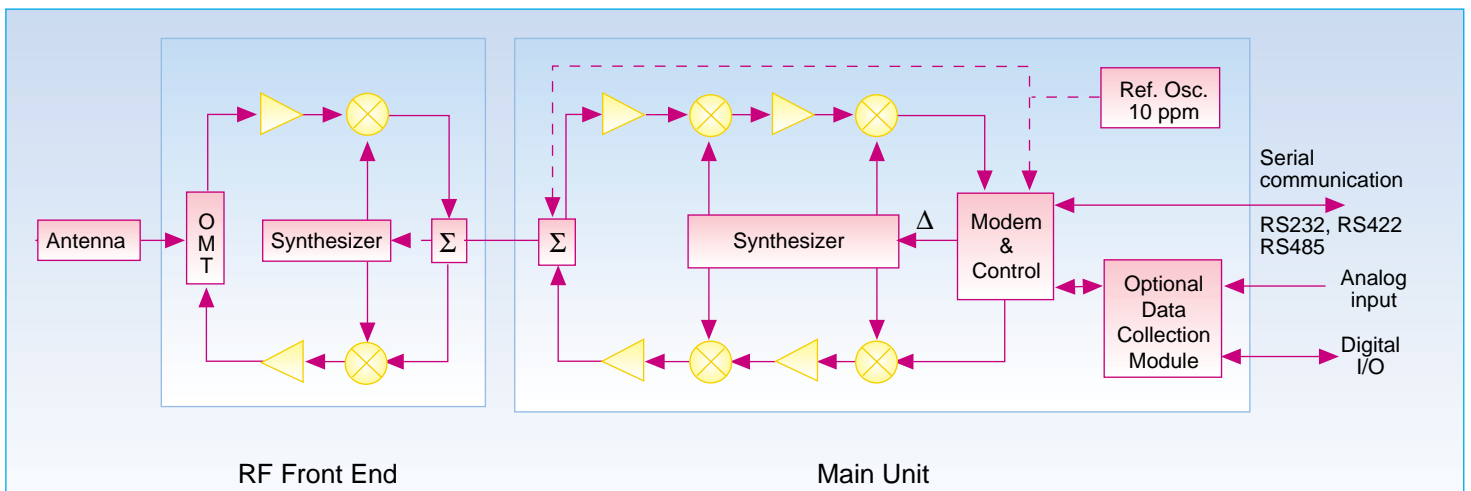
The Remote Terminal Communication Control Unit (CCU) receives and analyses the data from the transmission system, and performs the requested actions. The CCU also includes the user interface hardware and software.

#### 5.3.3 Hub Station

The Hub Station forms an integral part of a closed cost-effective total system, with the Hub Station installed close to the users' data collection centre or control centre.

The converter chain design in the Hub transmission system is identical to the design in the Remote Terminal, with the exception of utilising a more stable reference oscillator (stability of  $10^{-9}$ ), and will not be further commented. The other Hub modules are briefly commented below.

The Hub antenna is 1.8 m or 1.2 m in diameter, and of the same type as the



**Figure 5 Remote Terminal block diagram.** The block diagram shows the main modules in the Remote Terminal, divided into the RF Front End and Main Unit. An optional digital/analogue interface module is also included

Remote Terminal antennas. The Hub Main Unit may include several demodulators, corresponding to the number of inbound links.

The Hub Communication Control Unit (CCU) sends and receives data between the transmission system and the Network Supervisory Terminal (PC) at the Hub Station, performing the overall network control. Additional equipment is added when several inbound channels are required.

#### 5.4 Communication protocols and network management

The Remote Terminals share one or several satellite channels (inbound links) with a transmission delay of approx. 260 ms.

With the outbound link, the Hub can control several inbound links (on separate frequencies), where the access protocol may be separately optimised to the specific traffic and user requirements for each channel.

The TSAT network is controlled by the network control and management system in the Supervisory Terminal. The network operator at the Supervisory Terminal may reconfigure the network parameters, and access network status and statistics, through the network management interface in the Supervisory Terminal. The Supervisory Terminal is the gateway between the TSAT system and the user's computer system, including the gateway to public or private networks, if required.

##### 5.4.1 Communication protocol

The TSAT system is capable of offering an efficient use of the available channel capacity for applications with varying requirements. The network is therefore designed with a large degree of flexibility. The network access methods and protocols can then be tailored to meet specific user requirements regarding network traffic, response time, number of Remote Terminals, etc.

The key design issues for the inbound link access protocol is flexibility and simplicity. The varying applications for TSAT demand optimisation of the access protocol to meet specific user requirements. The basic TSAT access protocol is a modified Slotted Aloha random access protocol (9). The frame structure of the outbound and inbound link is shown in figure 6.

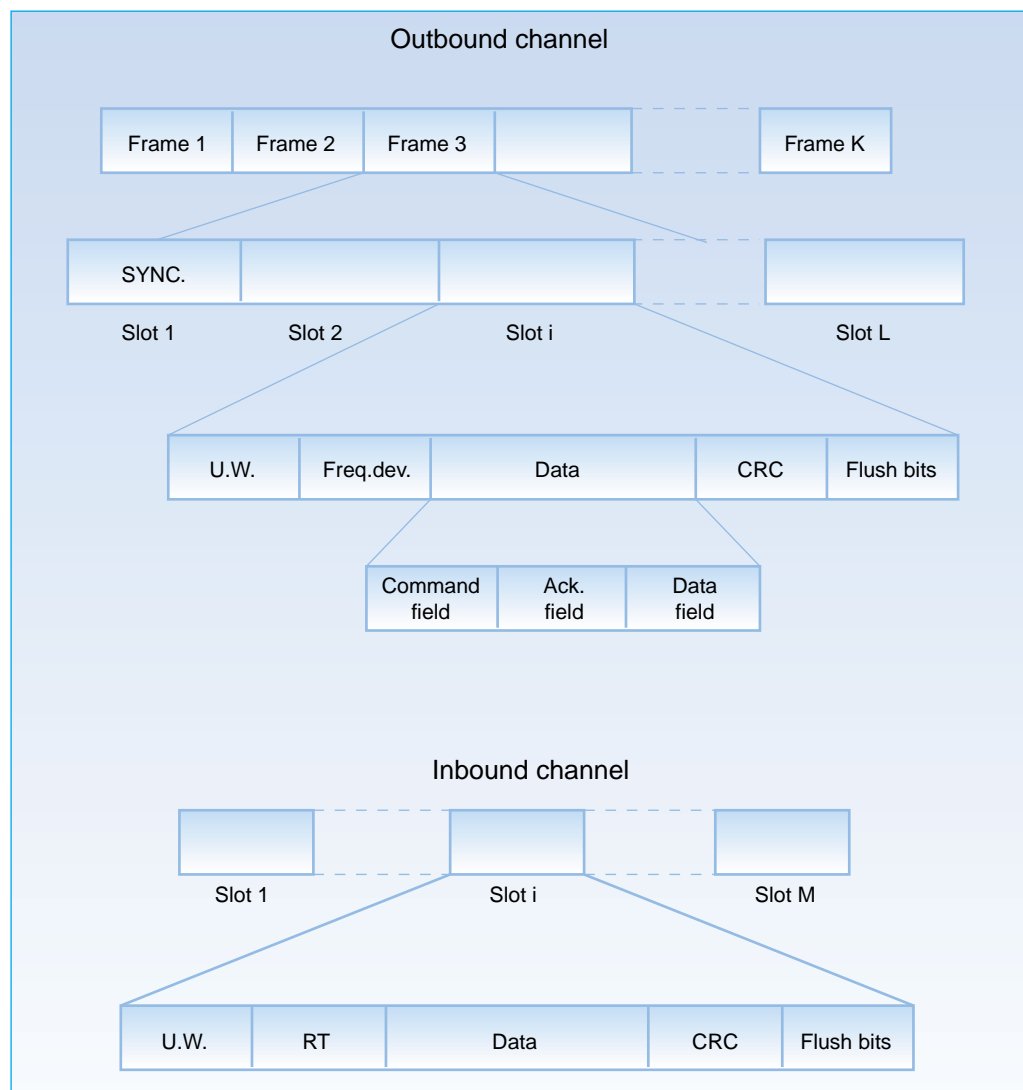


Figure 6 The broadcast TDM outbound link controls and commands the Remote Terminals. The Remote Terminals share the inbound link(s) according to a modified Slotted Aloha protocol

The TDM outbound link consists of a frame divided into slots and subslots with data fields. The frames are broadcast to all the Remote Terminals. The start of a frame is identified by a unique data packet in the first slot. This slot contains management information for controlling the Remote Terminal transmit frequency, and must therefore be received before the RT can transmit on the inbound channel. The slot also contains other management-related information, such as log-on frequency, network configuration, and protocol parameters. A data packet, transmitted in one slot, consists of fields containing unique word, frequency deviation, data, CRC, and flush bits.

By letting the slot structure on the outbound link control and synchronise the inbound link slots, each slot on the inbound link is referred relatively to the frame start on the outbound link. These features enable the TSAT system to be tailored to meet various user requirements, maximising the channel utilisation.

Slotted Aloha is implemented as the basic access protocol. Slotted Aloha is a random access protocol allowing a reasonable channel utilisation. The simplicity in the basic protocol eases implementation and reduces system complexity. Simple modifications of the protocol, e.g. assigning different priorities or traffic types to various slots in the frame, may let the user in a simple manner optimise the network performance. The flexible design allows more complex protocols to be implemented if required.

The slotted Aloha protocol allows the Remote Terminals to transmit data packets at the beginning of the first available slot. (Information about the slot status is broadcast by the Hub.) The length of the slot is configurable, dependent on the application type assigned to the inbound channel. The data packet on the inbound link consists of a unique word, RT address, packet length, data, CRC, and flush bits. The slot access is controlled by the values in an array where the N array elements correspond to the N

slots in each frame. Each RT is configured with initial values in this array, with one value for each slot determining the slot access. The number of allowable values affect the degree of traffic control.

#### 5.4.2 Network control

The network control and management system evaluates the statistics collected from the network units, such as the retransmission level and response delay, and performs the necessary actions to prevent the network from reaching congestion and instability. The user can configure network and protocol parameters, enabling the system to meet the requirements of interest.

#### 5.5 User interface

The Standard Remote Terminal is serial communication ports. Other interfaces are optional user interface. An optional data collection module, allows digital and analogue I/O to be interfaced directly with the Remote Terminal.

The Hub Station includes the Supervisory Terminal containing the Network Control and Management system. The Supervisory Terminal may be interfaced to the user's computer system, or to external private or public networks. Serial communication ports are standard, with other interfaces being optional (X.25, X.21, TCP/IP etc.).

The TSAT system may be used as a direct replacement of existing modems connected to terrestrial lines. The TSAT system may also be configured to include the direct interface and control of the connected equipment and instruments, resulting in a simplified total solution.

### 6 TSAT system status

A feasibility study of the TSAT concept was completed in December 1990 (5), with a laboratory demonstration proving the expected performance of all critical modules. The bit error rate and frequency tracking performance were demonstrated to be within specifications, with nominal thermal noise and phase noise added.

A full duplex TSAT link was demonstrated on a Hub and RT laboratory model in December 1991, confirming the expected performance of the complete transmission hardware and the digital modem software.

A complete demonstration network has been in operation since autumn 1992 through the INTELSAT VA satellite. From winter 1993, three pilot systems are in operation, collecting data in customer networks. The TSAT 2000 system will be commercially available from autumn 1993.

### 7 Acknowledgements

The TSAT development and experimental verification is sponsored by European Space Agency, Norwegian Space Centre and Norwegian Telecom.

Normarc has co-operated with the sub-contractors SINTEF DELAB (digital modem and OMT development), Scandpower A/S (communication protocols feasibility study and design), and Informasjonskontroll A/S (communication protocols design and implementation).

### References

- 1 Pettersen, T. *Satellite Data Collection System at Ku-band*, European Microwave Conference, 1990.
- 2 Pettersen, T. *Closed low-rate satcom network with optimised utilisation of the geostationary orbit*, Telecom '91, Technical Symposium.
- 3 Amundsen, P C, Pettersen, T. *The TSAT System - A Novel Low-cost closed Satcom network for Low Data Rate Communication*, 9th. Int. Conf. on Digital Satellite Communications, Copenhagen, May 1992.
- 4 Huseby, K, Lie, A. *Software and functional description of a digital MODEM for the TSAT satellite data collection network*, SINTEF-DELAB Report, STF 40 F91140, Jan. 1992.
- 5 Normarc a/s, supported by DELAB and Scandpower A/S. *Design and development of a satellite data collection system at Ku-band*, Final Report to ESTEC Contract No. 8709/90/NL/RE.
- 6 Alper J R et al. *The Book on VSATs*, Gilat Communication Ltd.
- 7 Matyas, R. Effect of Noisy References on Coherent Detection of FSK Signals, *IEEE COM-26*, No. 6, June 1978.
- 8 Bjøntegaard, G, Pettersen, T. An Offset Dual-Reflector Antenna shaped from Near-Field Measurements of the Feed-Horn: Calculations and Measurements, *IEEE Trans. AP-31* no. 8, November 1983.
- 9 Pettersen, T. *Dual Shaped Offset Reflector Antennas. Documentation of experience and calculated and measured results*, TF-report 35/87. Norwegian Telecom Research., June 1987.
- 10 Skyttemyr, S. *Radiation Pattern and Gain Measurements on shaped Offset Dual-Reflector 90 cm Antenna*, Norwegian Telecom Research Measurement Report, November 1988.
- 11 Tanenbaum, A S. *Computer Networks*, Prentice-Hall Inc., 1981.

# Very Small Aperture Terminal (VSAT) systems - basic principles and design

BY LIV ODDRUN VOLL AND GUNN KRISTIN KLUNGSØYR

## 1 Introduction

The telecommunications industry is constantly developing to meet the changing needs of the users.

Through new technologies telecommunications service providers can:

- Expand the network coverage to new areas
- Improve the quality of basic communications services
- Reduce the costs of services to allow more users
- Add new services to increase the value of telecommunications services to users.

An important part of the recent development in telecommunications is the introduction of VSAT systems.

Very small aperture terminal (VSAT) systems have developed rapidly over the last years, and have been a major part of the recent development within the satellite communication industry. VSAT networks have been a success mainly because they address a topology that appears to be ideally suited to satellite communication - point-to-multipoint. Traditional terrestrial networks always had trouble addressing

this requirement. Accompanied by various systems for mobile communication, this development has made satellites an attractive medium to a large number of users based on cost/performance advantages.

VSAT networks are characterised by a large population of small and inexpensive earth stations (VSATs) at the customer's premises. They communicate through relatively small antennas with a central large earth station called the hub station (figure 1). The hub station includes a Network Management System (NMS) which is responsible for the monitoring and control of remote VSATs. The communication with the terrestrial network is also via the hub node.

The VSATs operate as part of a satellite network used for the distribution and/or exchange of data between users. It is difficult to give a precise definition of a VSAT system because of the lack of standardisation. A VSAT is usually defined as a terminal with an antenna with diameter 2.4 m or less, which is likely to provide digital services of 2 Mbps or less (1). Such services are data distribution, data networking, voice services and digitally compressed videoconferencing services.

## 2 Specifications

621.396.946

### 2.1 VSAT

In order to get a more precise definition of VSAT systems the European Telecommunication Standards Institute (ETSI) has proposed the following specifications of the transmit and receive terminals (2):

- Operating in the exclusive part of the Ku-band allocated to the Fixed Satellite Services (FSS), 14.00 to 14.25 GHz (earth-to-space), 12.50 to 12.75 GHz (space-to-earth), and in the shared parts of the Ku-band, allocated to the FSS and FS (Fixed Services), 14.25 to 14.50 GHz (earth-to-space) and 10.70 to 11.70 GHz (space-to-earth)
- In these frequency bands linear polarisation is normally used and the system operates through satellites with 3 degree spacing
- Designed for unattended operation
- Limited to reception and transmission of baseband digital signals
- The information bitrate transmitted towards the satellite shall be limited to 2.048 Mbps

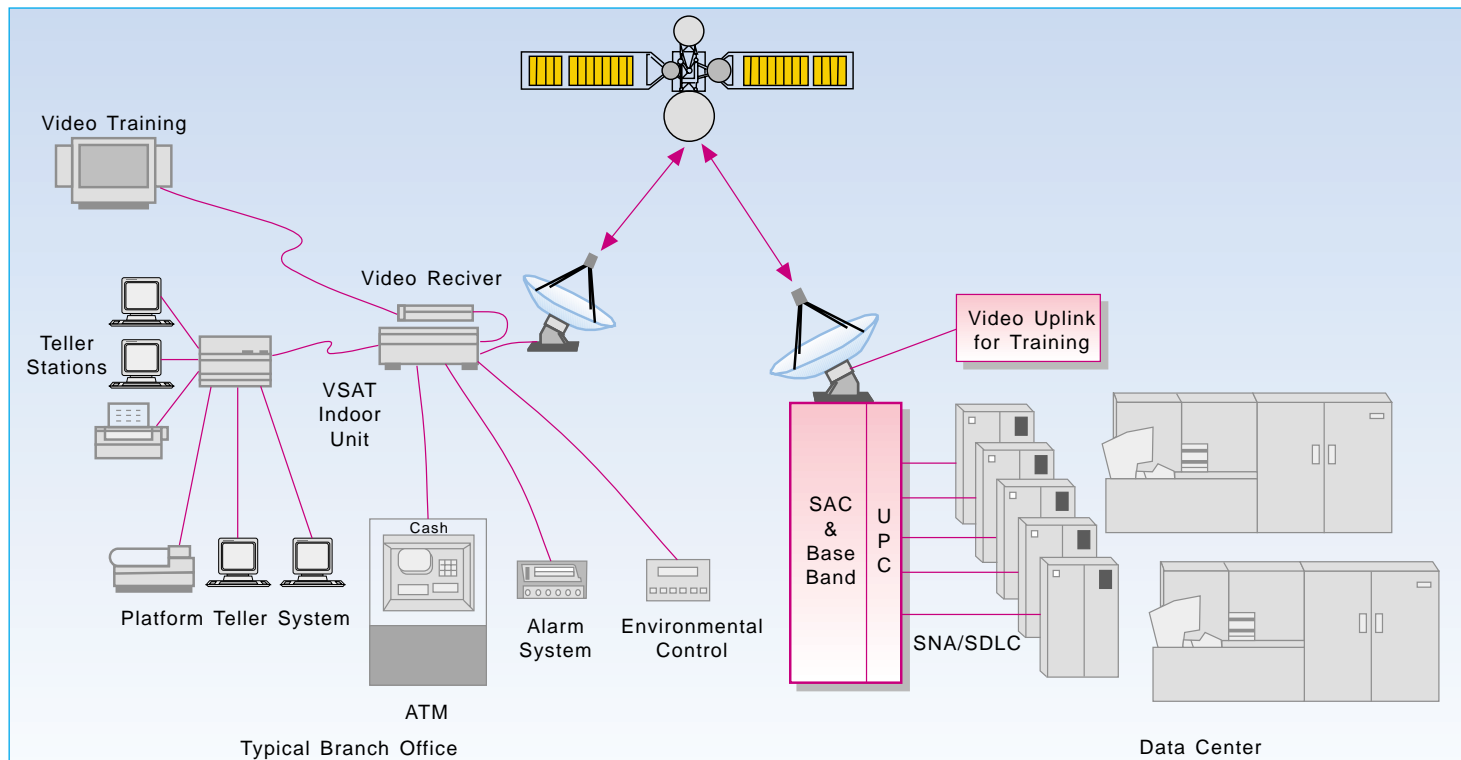


Figure 1 Example of a VSAT network in a Banking Environment

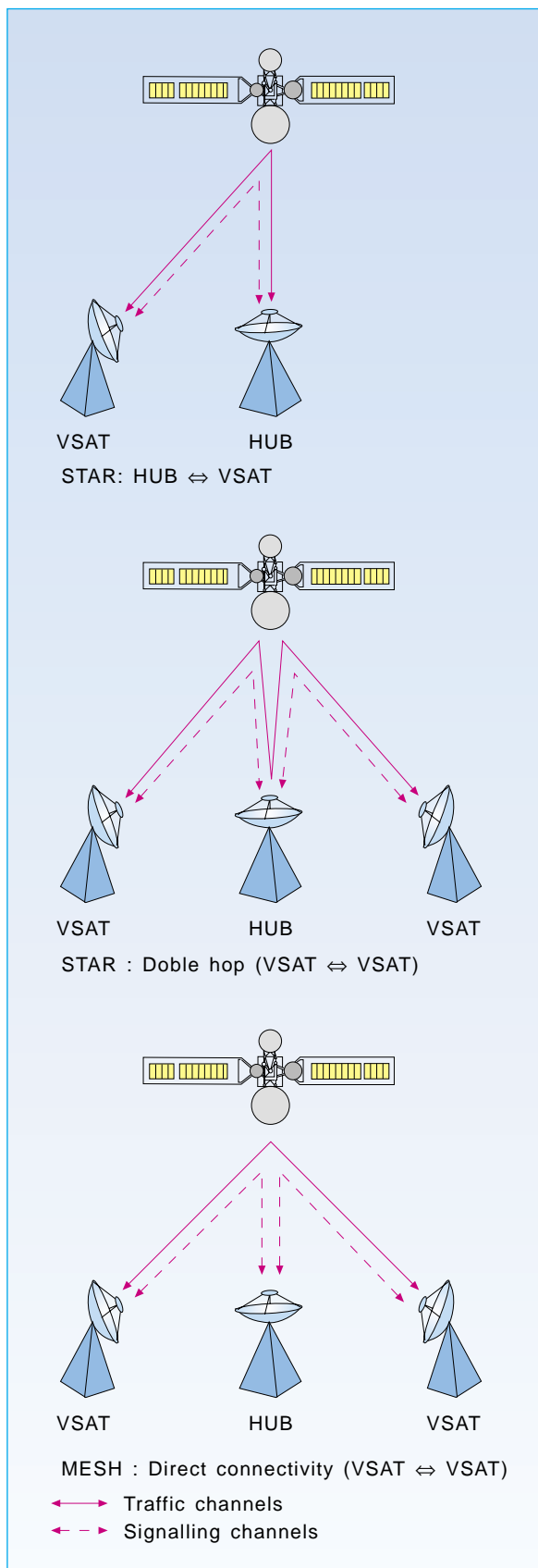


Figure 2 VSAT system topologies: star topology and mesh topology. Mesh topology offers direct connectivity between the remote VSAT terminals

- Antenna diameter not exceeding 3.8 m or equivalent corresponding aperture.

The equipment characterised comprises both the “outdoor unit” and the “indoor unit”. The outdoor unit is usually composed of the antenna subsystem and the associated power amplifier and Low Noise Converter (LNC). The indoor unit is composed of the remaining part of the communication chain, including the cable between the indoor and outdoor units.

This standard does not contain the VSAT network hub station.

## 2.2 Hub station

The entire network is organised by the hub station via the network management system (NMS). The operator of the network management system is responsible for the following essential functions:

- Monitoring and controlling the network
- Configuring the network
- Troubleshooting the network
- Charging.

Communication between the NMS and network components is continually maintained. The NMS regularly polls the nodes of the network to obtain normal activity statistics, information about system failures and error recovery.

The VSAT systems present two kinds of topologies: star topology and mesh topology (figure 2).

The *star topology* is the traditional VSAT network topology. The communication links are between the hub and the remote terminals. This topology is well suited for data broadcasting or data collection. The only way to communicate between the remote terminals is via the hub station (double hop). This makes it impossible to offer speech services between the terminals, because the time delay in the double hop (500 ms) is too severe.

The connectivity on the space segment is provided by digital carriers in both directions, organised with various access schemes. The access techniques used in a star network can be both FDMA (frequency division multiple access), TDMA (time division

multiple access), and CDMA (code division multiple access), but TDMA is the most common. The inbound channel (remote VSAT to hub) often use slotted Aloha which is a form of Random Access (RA).

In *mesh topology* there is direct communication between the remote VSAT terminals. This minimises the time delay which is critical concerning speech services. The internal signalling network will have a star topology, because the signalling processor is located in the central node, which is often referred to as the DAMA (demand assignment multiple access). The access method used in a mesh network is typically Frequency Division Multiple Access (FDMA).

## 3 Evolution

Since their introduction VSATs of this kind have followed an evolution through which three distinct generations can be identified. The first generation of VSATs demonstrated, in the late 70s and early 80s, the feasibility of transmit and receive data communication systems. The second generation introduced the reduction of antenna size due to higher EIRP (effective isotropically radiated power) Ku-band satellite channels, and the advent of basic network management systems. VSATs of the third generation (developed since 1987) are characterised by designs taking into account the need for open and standard architectures. Many of these VSATs operate in switched networks based on architectures corresponding to the standards of the telecommunications industry such as X.25.

The earliest VSAT systems had a STAR topology and they started in the USA during the late 70s, largely in private corporate networks containing thousands of sites. Some 85 per cent of the world's VSATs are located in the USA, and about 90 per cent of US VSATs are in private dedicated hub networks operated for only one corporate user (3). In Europe this private VSAT solution will not be the rule since regulation and other issues will drive most customers to utilise a shared VSAT hub operated by a VSAT Service Provider. The average number of VSATs per hub might, in the USA, approach 800, but internationally the number is closer to 100 sites per hub.



For some years also meshed VSAT systems have become available. An application is for example telephone services in areas with insufficient terrestrial networks. Circuits are designed on demand, allowing for an efficient use of the space capacity. More recently, high rate (typically 2 Mbps) VSAT services were introduced (for example the NORSAT-B system). What these systems have in common is that they require more powerful VSAT stations and a high down-link power. Consequently only a small number of carriers (channels) can be supported by a satellite transponder and transmission costs are correspondingly high.

The available access techniques allow for inherent flexibility. TDMA (time division multiple access) gives the best flexibility, but at the price of high earth station costs. When using FDMA/SCPC (single carrier per channel) flexibility is limited and earth station costs are lowered but remain still on the high side. In other words, high rate meshed VSAT communications are currently handicapped by the need to operate powerful earth stations and by relatively high transmission costs.

## 4 VSAT systems in Norway

As examples of VSAT systems two of the VSAT systems in Norway are described: NORSAT-B and NORSAT PLUS. NORSAT-B, which is a well established system, is given a fairly thorough description. NORSAT PLUS, which is a conventional VSAT system, is just briefly introduced.

### 4.1 NORSAT-B

In 1976 Norway became the first country in Europe to use satellites in its domestic telecommunications network. This first system, NORSAT-A, was originally established to handle the telecommunications traffic to the oil installations on the Norwegian continental shelf and the Arctic islands of Svalbard.

As the next step NORSAT-B was developed in Norway by EB Nera in co-operation with Norwegian Telecom. This satellite system became operative in 1990. In addition to the areas served by NORSAT-A, NORSAT-B was planned to provide business communication on the Norwegian mainland. Lately further expansion to a complete European market has been considered.

#### 4.1.1 Network configuration

NORSAT-B consists of one main earth station (MS) and a network of user stations (US) sited at the users' premises. The main station is located at Eik earth station outside Stavanger. All establishment of connections, monitoring and control of the network and the transponder is done from this station. It also takes care of all charging information.

From a signalling point of view, it is a star network. That is, *signalling* between two user stations will always go via the main station. Concerning traffic, it is a meshed network with direct US to US connectivity. That is, the *traffic* itself is conveyed directly between user stations. In this way single-hop traffic, which minimises time delay, is offered.

Signalling information between the main station and the user stations is exchanged by using dedicated signalling channels. The main station is continuously broadcasting on a Broadcasting Signalling Channel, while the user stations share the capacity of a Common Signalling Channel.

Transponder capacity for user data traffic is shared among user stations in FDMA (Frequency Division Multiple Access).

NORSAT-B is designed for using a Ku-band transponder, that is 14 GHz up-link and 11/12 GHz down-link. Today a transponder in INTELSAT VA (359° E) is used. This transponder covers Northern and Central Europe (figure 3). Satellites from EUTELSAT and the next generation of INTELSAT satellites (INTELSAT VII, 1994) give better European coverage. Most likely NORSAT-B will be transferred to INTELSAT VII when this satellite is ready for use.

#### 4.1.2 Available bitrates and connection types

Today the available bitrates are  $N * 64$  kbps, where N is 1, 6, 12, or 32. That is, NORSAT-B offers digital connections from 64 kbps to 2 Mbps. The next generation of NORSAT-B terminals will probably include N = 2, 3, 4, 5, 10, 15, and 20 as well.

The type of connections possible in NORSAT-B are point-to-point, point-to-

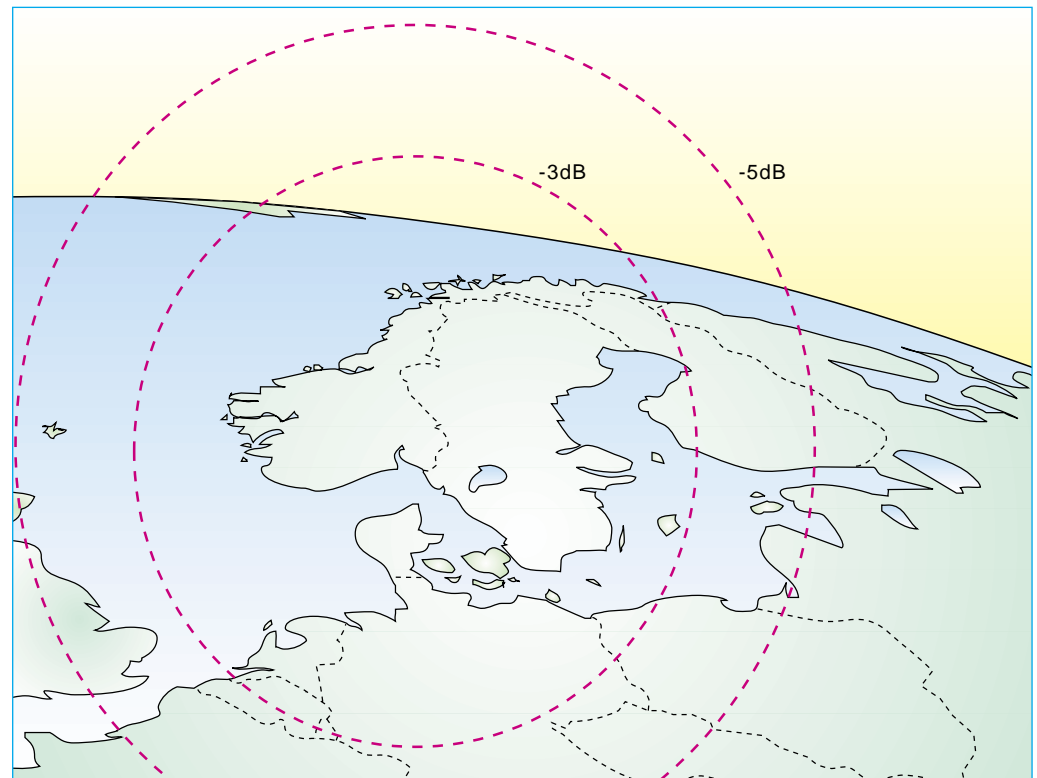


Figure 3 Coverage of the Intelsat VA transponder used for NORSAT-B

multipoint and multipoint-to-multipoint (conference). Both duplex and simplex connections can be offered, and transmit and receive bitrates can be chosen independently.

#### 4.1.3 Establishment of connections

NORSAT-B allows connections to be established in three different ways:

- *Fixed circuits:* This corresponds to leasing fixed lines. The capacity in the satellite is permanently reserved, and cannot be used by others, irrespective of whether or not one chooses to transmit information all the time.
- *Prebooked circuits:* Some time in advance the customer makes an order for a circuit to be set up between specified user stations. This order is fed into the main station, which then establishes the circuit at the desired time.
- *Switched circuits:* The circuit is connected and disconnected on demand, at request from the user. The necessary information concerning the circuit can be pre-stored in the user station, or fed into it from a manual keyboard.

Prebooked and switched connections will compete for the same network resources. If establishment of a prebooked connec-

tion is impossible due to network congestion, an alarm will be given.

#### 4.1.4 Charging

For fixed connections you pay a fixed price a year. This price depends on bandwidth used. For both switched and pre-booked connections costs are charged only for the call duration. Price per minute depends on bandwidth used.

If specified, charging information is available on a per call basis. This will be transmitted after disconnection.

#### 4.1.5 User stations

Two standard types of user stations are defined, referred to as Standard A and Standard B. Any user station which cannot be classified according to these standards is assigned to a third group called Standard S (specially built stations).

The *Standard A* station uses an offset type antenna of 3.3 metres diameter. The station offers all available bitrates: today they are 64 kbps, 384 kbps, 768 kbps and 2.048 Mbps.

The *Standard B* station is the smallest one. The antenna diameter is 1.8 metres. The station offers only 64 kbps connections.

The *Standard S* stations are "customer built". They can be adapted to the needs of the individual customer. Possible variants may be stations with duplicated equipment to fulfil stringent requirements on communications reliability, stations with non-standard sizes of antenna or transmitters, or stations with additional channel units.

#### 4.1.6 Applications

NORSAT-B was one of the first high speed switched systems available. High speed connections (2 Mbps) are used for bulk data transfer. Examples are transmission of pictures from the ERS-1 satellite from Tromsø Satellite Station to FFI at Kjeller and transmission of environmental data from Finnmarksvidda to Kjeller (NORSAR). This represents large amounts of data to be transferred (figure 4).

2 Mbps connections are also used for remote printing of newspapers. In this way the newspaper can be printed simultaneously at several places, reducing both transportation costs and distribution time.

Another application is video conferencing. The conferencing is not limited to two parts only (max five parts). The video conference market has been expected to grow rapidly for years, but the growth is still slow.

NORSAT-B is also used as back-up for terrestrial circuits when a high degree of reliability is imperative. This increases reliability because NORSAT-B terminals are installed at the users' premises and the network is independent of other telecommunications networks (figure 5).

Since NORSAT-B offers single hop traffic (transmission delay of 250 ms), speech transmission is of acceptable quality. In addition to fax and other lower rate data transmissions, it can therefore be used for ordinary telephone connections.

NORSAT-B's advantage is its flexibility. The user is allowed to set up a variety of different network topologies ranging from simplex point-to-point to full duplex multipoint-to-multipoint. Bitrates can be chosen from 64 kbps to 2 Mbps independently for transmitting and receiving. This can be utilised in companies spread over a large geographical area with need for a wide range of communication facilities. The

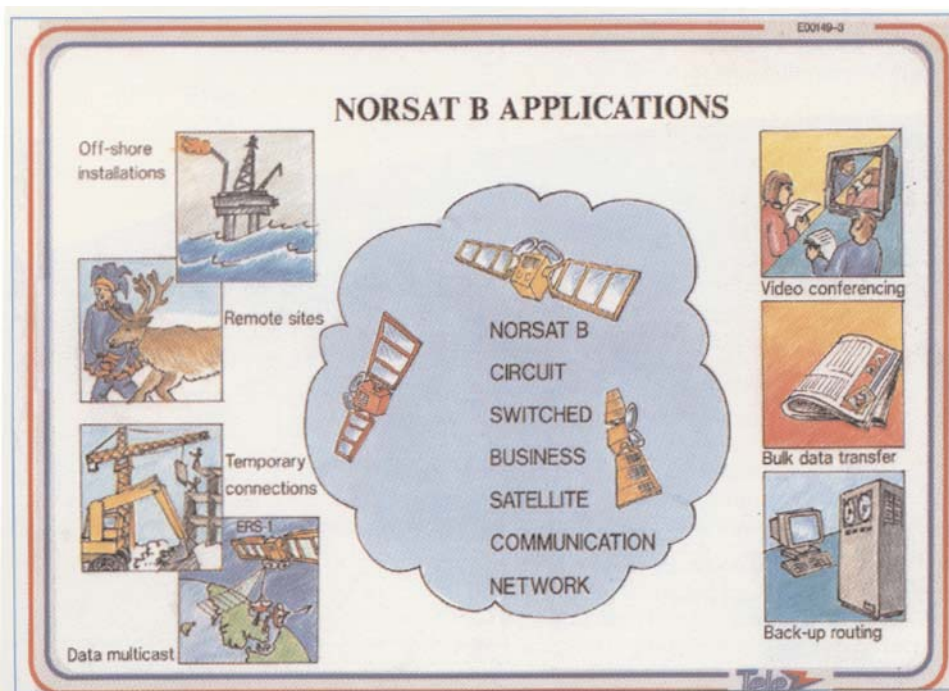


Figure 4 Examples of NORSAT-B applications

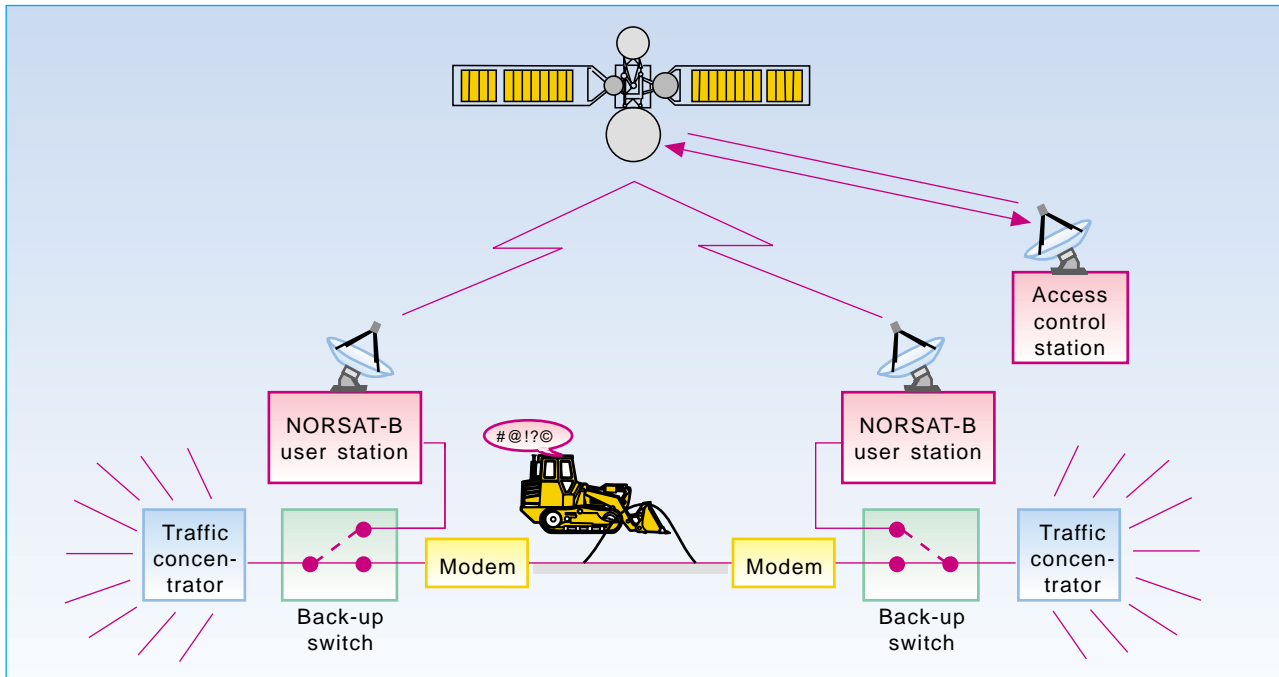


Figure 5 NORSAT-B used as back-up for terrestrial circuits

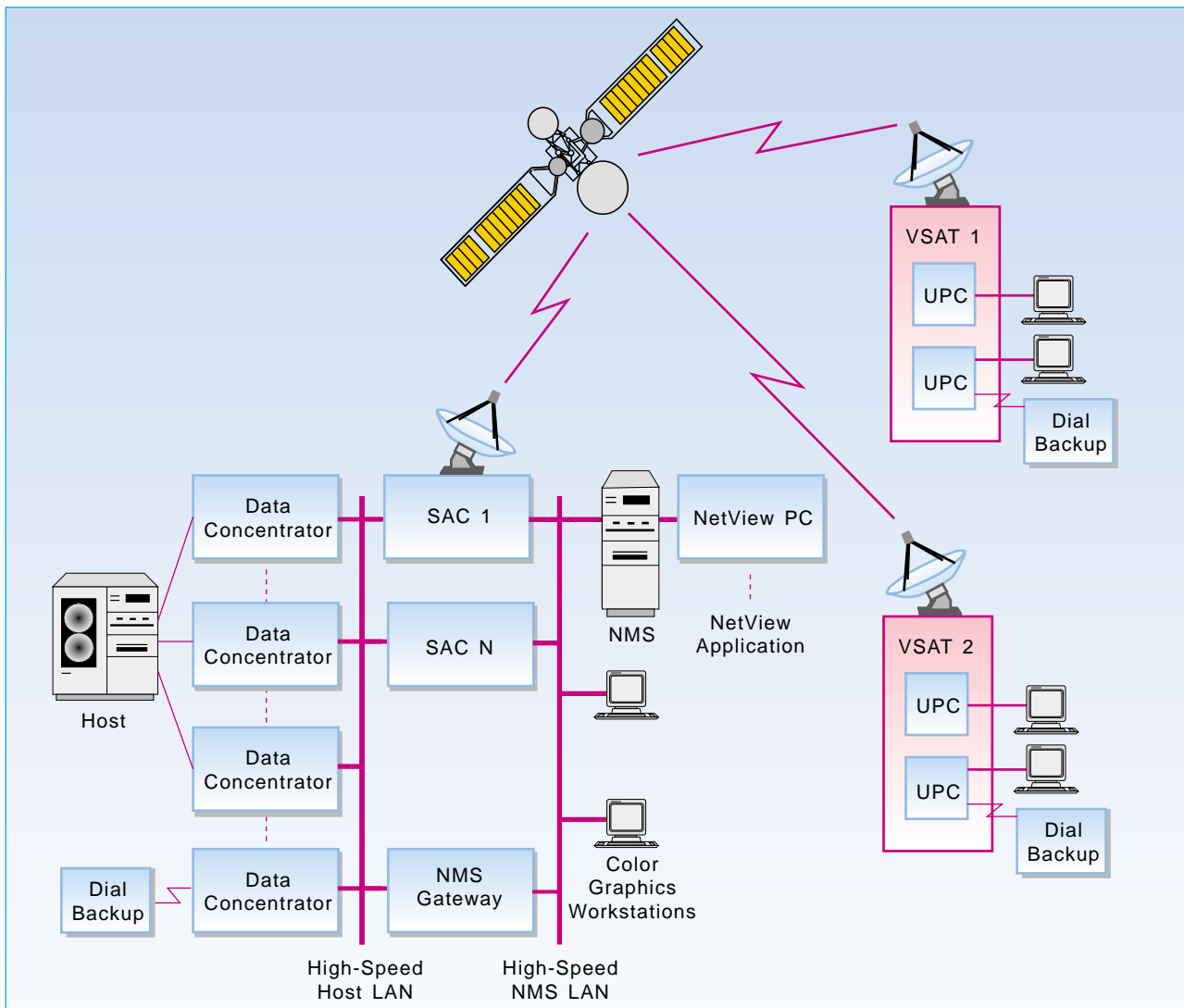


Figure 6 NORSAT PLUS Network

same system can be used for data transmission of different bitrates, video conferences, distance education, telephone and fax services, etc.

Another example of integration of services can be in telemedicine, where both video conferences, distance education, transmission of data and pictures with different resolutions are needed.

NORSAT-B's main drawbacks are the high price level and the limited coverage area (see figure 3). The coverage area problem will probably be reduced when Intelsat VII comes into operation in late 1994.

The price level can be reduced when new and cheaper user stations are available. Such stations are under development. A large part of the total costs is due to the satellite transponder, and can therefore be reduced if the number of users increases.

## 4.2 NORSAT PLUS

NORSAT PLUS is a two-way VSAT star-type network which will be put into operation autumn 1992. It consists of a hub station, multiple remote sites, and a network management system with colour graphics user interfaces (figure 6). The hub is located at Nittedal Earth Station and is operated at a 24 hours/day basis. The system offers data transmissions up to 64 kbps and supports IBM SNA and X.25 protocols in standard configuration. The system is manufactured by GTE Spacenet. It is operating in Ku-band with 1.2 metre antennas and will make use of INTEL-SAT V space segment. NORSAT PLUS is dedicated to business data communications and primary application is expected to be typically transaction oriented database enquiry and selective data broadcasting from a central database to groups of users.

### 4.2.1 Hub Station

The hub station resides at the central network facility to provide host connectivity into the network. Hub station components include:

- Hub Radio Frequency (RF) Equipment
- Satellite Access Controllers (SAC) - SACs provide logic for processing transmission and receipt of data via satellite

- Data Concentrators (DC) - DCs provide device (host ports, modems, printers, etc.) connectivity in 8 ports building blocks into the network. DCs operate protocols at user selectable port speeds up to 64 kbps. DCs support protocols, including IBM SNA (System Network Architecture) and X.25. With the unique "plug and play" architecture for protocol support, additional protocols can be easily implemented
- Network Management System (NMS) - the NMS provides complete control and monitoring facilities for network operation.

The hub station components are connected via a high-speed LAN.

### 4.2.2 Remote Sites

Each network location is equipped with a VSAT where all communication devices are located indoors with the exception of the satellite dish and the outdoor unit (ODU). Each VSAT may contain up to two Universal Protocol Cards (UPC). VSAT UPCs support one or more protocols (up to four), including SNA and X.25, allowing connectivity for a wide variety of devices.

### 4.2.3 Satellite Access Methods

NORSAT PLUS uses the Adaptive Assignment Time Division Multiple Access (AA/TDMA) method and the Permanent Assignment Time Division Multiple Access (PA/TDMA) method for inbound (remote to hub) transmission, and continuous time division multiplexed (TDM) for outbound (hub to remote) transmission. Both inbound and outbound carriers offer data transmission at bitrates up to 64 kbps.

## 5 Future trends

Dr Golding at Hughes Network Systems has stated that future trends in VSAT networks will be driven by the following goals (4):

- Lowering costs of the VSAT terminals, hub stations and installation of these networks
- Providing a greater range of service, including voice and compressed video services
- Providing networks that are more user friendly and flexible in terms of operations, administration and maintenance

- Integration of these networks with a larger variety of Customer Premises Equipment (CPE), and more advanced terrestrial networks including fibre optic networks, newer switching equipment and ISDN.

Today, integration of the VSAT networks with the terrestrial common carrier network is via gateways generally located at the hub station. In the future, the VSAT networks will be interfacing with the ISDN terrestrial network and multiple gateway interfaces may become more important with greater use of full mesh network architecture. It is important that in the selection of link and network layer protocol standards for ISDN, satellite networks will be considered with respect to unique properties of these networks, such as time delay and broadcast capabilities.

In addition to future trends in the VSAT ground networks one can expect new technology to be important in the space segment area. New communication satellites will incorporate the following features, which will have a significant impact on future VSAT networks:

- Amplifiers with higher output power
- Use of spot beams and scanning beams
- On-board processing
- Intersatellite links.

These features will permit higher capacity VSAT networks with lower cost earth stations and greater flexibility. The use of intersatellite links may provide direct connectivity and integration into other networks without requiring terrestrial connections. Direct integration with mobile networks may also be possible by this method.

VSAT systems have not grown as rapidly in the rest of the world as in the USA. This is mainly because of the regulatory environments. In order to make the situation in Western Europe approach the situation in the USA, the European Community intends to extend the applications of the generally agreed principles of Community telecommunications policy to satellite communications. This will implicate liberalisation of earth segment and terminals.

After the recent development in Eastern Europe this has been considered to be a new and very promising market for VSAT systems because of the lack of terrestrial networks. ESA (European Space Agency) has studied the market opportunities for VSAT networks in Eastern Europe. They conclude that the market for traditional business VSAT (star topology) is limited, but for the so-called "unconventional" VSAT systems (mesh networks), which offer telephony, the market appears to be very promising (5).

## References

- 1 Pelton, J N. International VSAT Applications and ISDN. *IEEE Communications Magazine*, 60-61, May 1989.
- 2 ETSI. *Satellite Earth Stations (SES); Transmit/receive VSATs used for data communications operating in the FSS 11/12/14-GHz-bands*. (DE/SES-2002), ETS 300 159, February 1992.
- 3 Mesch, R G. Shared VSAT Hub Expectations. *VSAT '91 Conference & European Satellite Users Show*, Luxembourg, 5-7 November 1991.
- 4 Golding, L S. Future Trends in VSAT Networks. *IEEE Communications Magazine*, 58-59, May 1989.
- 5 Pinglier, A. Marked opportunities for VSAT networks in Eastern Europe. In: *Proceedings of The 8th European Satellite Communications Conference*, London, December 1991, 129-139.

# Fleet management using INMARSAT-C and GPS - a Norwegian pilot project

BY ARVID BERTHEAU JOHANNESSEN

621.396.946

## Introduction

In the transport industry, communication with the land vehicles of the transport fleet has until recently been done through HF/VHF radio, cellular telephone or payphones along the road. For navigation, road maps have been the only choice. These methods, although well proven, all have major limitations and disadvantages. The vehicles are often difficult or impossible to reach, because of the limited coverage of these communication systems.

The introduction of satellite communication systems like INMARSAT-C and the satellite navigation system GPS (Global Positioning System), offers a wide range of new possibilities. This article briefly presents these systems and describes some applications related to them. Emphasis is given on a Norwegian pilot project, known as the "Sties Project", where a fleet management system using INMARSAT-C and GPS was tested in a real-life transport environment.

## INMARSAT-C

A major trend in satellite communication is the evolution towards small, portable terminals. INMARSAT, the International Maritime Satellite Organisation, has a central role in this evolution (1). INMARSAT is an international inter-governmental partnership for mobile satellite services, owned by 67 signatories. There is one signatory in each country. USA, represented by COMSAT, is the largest shareholder with 24.6 %. Norway, represented by Norwegian Telecom, has a share of approximately 10.7 %.

The work-horse of INMARSAT has until now been INMARSAT-A, a maritime communication system for telephony and telex services. This system has been operating since 1982, and today there are more than 20 000 ship terminals, known as ship earth stations, in use, and approximately 30 coast earth stations are established around the world as gateways to the terrestrial networks (2).

As the terminals grow smaller and become more portable, satellite communication has become more attractive to land mobile users. As opposed to terrestrial cellular telephone systems, the INMARSAT satellite systems offer global coverage and are independent of the specific systems of the different countries. This is also interesting when the growing traffic towards Eastern Europe is taken into consideration. A cellular system like GSM will most likely have its strength in high traffic areas, but the satellite systems are independent of the local infrastructure.

INMARSAT-C is a new system very well suited for land mobile use. The system uses L-band (1.5/1.6 GHz) through four satellites in the geostationary orbit. It is a system for transmission and reception of low rate data with a 600 bit/s bit rate. From the terrestrial networks, it is available through telex, X.25, X.400 or through a normal telephone connection, using a modem. The system offers global coverage divided into four satellite regions:

- Atlantic Ocean Region East (AOR-E)
- Atlantic Ocean Region West (AOR-W)
- Indian Ocean Region (IOR)
- Pacific Ocean Region (POR).

Each of these satellite regions is handled by several coast earth stations. The INMARSAT-C mobile earth station is small and compact and is operated through a standard laptop PC and dedicated software. Among the manufacturers of INMARSAT-C mobile earth stations are Norwegian ABB Nera and Danish Thrane & Thrane.

Using INMARSAT-C, the driver is able to communicate with the headquarters, other vehicles or the receiver of the cargo anytime and anywhere through text messages. The headquarters may send broadcast messages to the entire transport fleet or part of the fleet. In addition, the system can automatically transmit reports from the vehicle, containing data like the cargo temperature or the vehicle position.

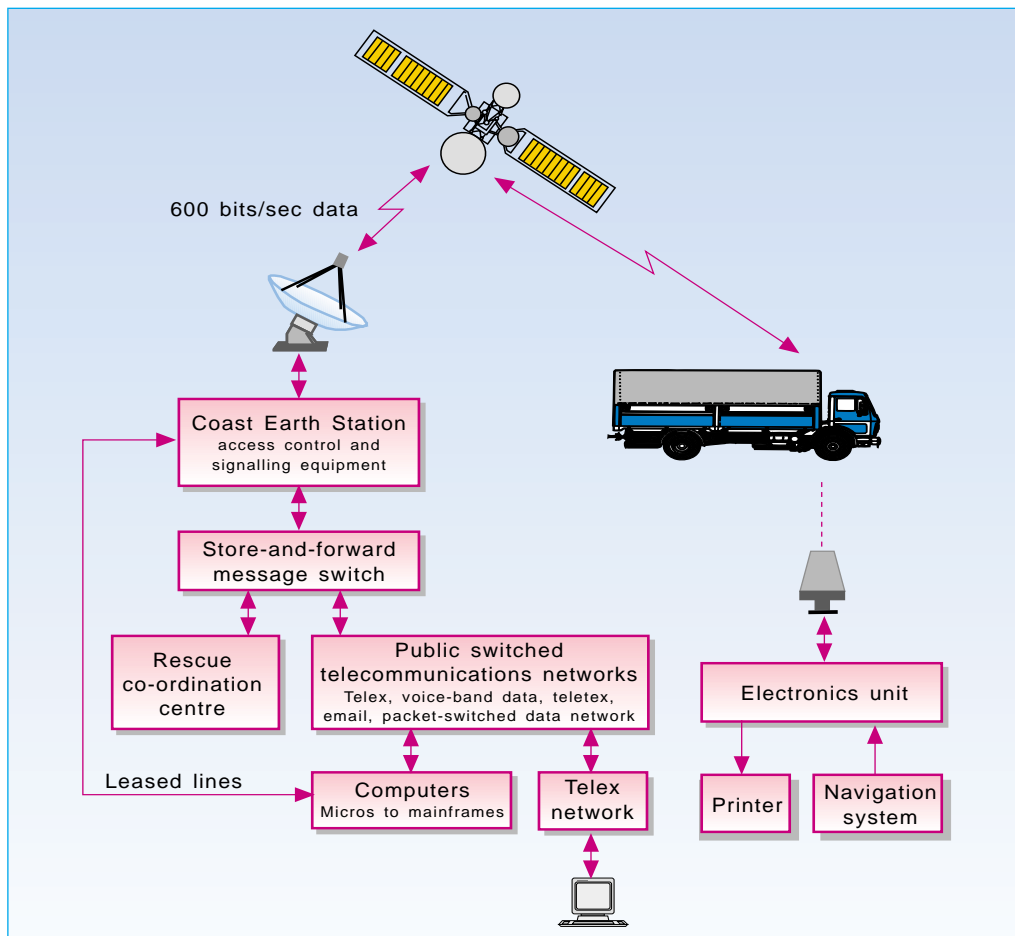


Figure 1 The INMARSAT-C system

## GPS (Global Positioning System)

For the determination of the vehicle position, GPS (Global Positioning System) is the system by choice. GPS is expected to be fully operational during 1992 - 1993 and operates through 24 satellites (21 operational plus 3 back-up) in an approximately 20,200 km height orbit (3). By receiving the signal of three satellites, the position in two dimensions is calculated with an accuracy of 50 - 100 m. By receiving signals from four satellites, the position in three dimensions is calculated. GPS receivers are manufactured by a number of manufacturers. The size of the receivers is still decreasing, and the prices are still falling. The INMARSAT-C terminals are equipped with a serial interface so that a GPS receiver may be connected for automatic or manual transmission of positions.

The above mentioned position accuracy should be sufficient for the monitoring of transport fleets. For navigation, a higher accuracy is required. There are several possibilities for obtaining such an increased accuracy. One possibility is *differential GPS*. By establishing fixed reference stations, the difference between the position received by GPS and the actual known position of the reference station can be calculated and transmitted as a correction signal to the mobile users operating within a distance of the reference station. Differential GPS offers an accuracy of 1 - 5 metres even for moving objects. In Norway, Statens Kartverk has established such a system called SATREF.

INMARSAT-C terminals with integrated GPS receiver are also available. The two systems are very well suited for integration as the GPS receive frequency slot is allocated between the INMARSAT-C transmit and receive slots (approx. 1.5 GHz).

## Communication protocols in INMARSAT-C

INMARSAT-C is prepared to handle several types of information, and different communication protocols are defined (4), (5). In addition to the message protocol, protocols for a better utilisation of the transmission capacity are defined. A protocol for *data reporting* is defined. This protocol makes low cost transmission of short data

packages, such as position reports, possible. For position reporting, both maritime and land mobile formats are defined. The format for land mobile position reporting consists of 1 to 3 packets, each 15 bytes long, and contains: The position (longitude and latitude) in degrees, minutes and 1/100 minutes and the time of the position. In addition, short messages may be included in this format. These will by preference be MEMs (Macro Encoded Messages), which are predefined numbered messages. 255 numbers are allocated for these messages and some of them are already defined by INMARSAT, while some are left for custom definition. Another protocol is called *Polling*. This is a protocol enabling the fleet operator to poll the mobiles in order to request reports from them, or to send messages to them. Instead of the mobile sending periodically reports to the fleet operator, the operator may request this when necessary.

Typical polling commands may be:

- Send report immediately. (This command also includes information on what type of report is expected)
- Start reporting on a regular basis
- Stop reporting
- Receive text message.

## User needs and requirements

For a typical transport company, we can imagine several parties totally dependent on communication (6). Among these are the transport company headquarters, the drivers, the receivers of the cargo and external partners like insurance companies.

Some typical situations when *the headquarters* need to obtain contact with the drivers are when

- plans are changed
- rerouting the vehicles
- exchanging customs information
- the customer asks for his goods
- address of delivery is changed
- delay occurs.

Today, the headquarters are dependent on the drivers to call them, and problems appear when the driver does not call or is unable to get through. A mailbox service, or store-and-forward system like INMARSAT-C, omits the need for the parties to be constantly stand-by. Fast change of plans can be executed on a very short notice. Today, the vehicles are traced through border stations, forwarding agents or truck stops. Tracing the vehicles this way is time consuming and expensive.

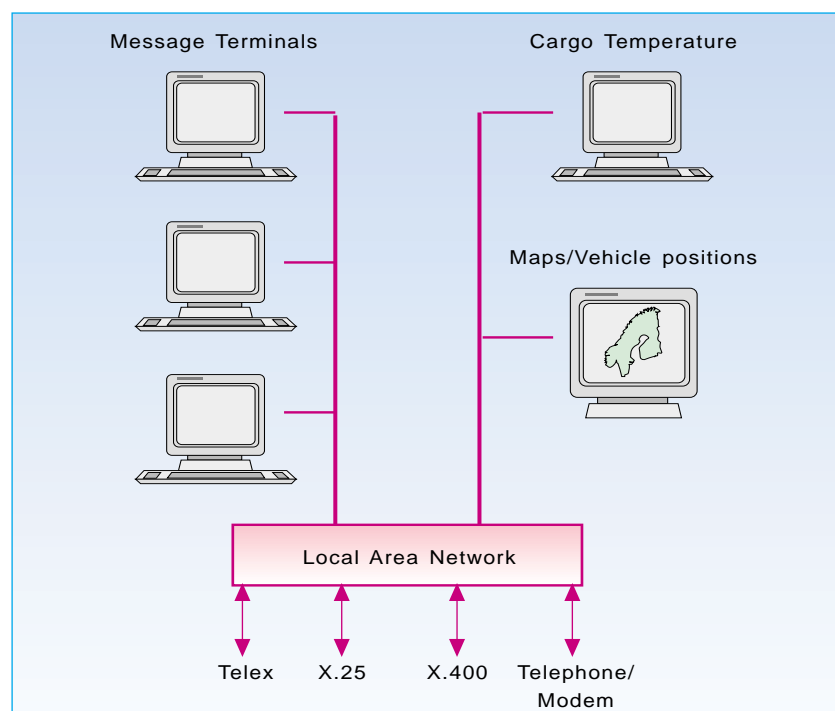


Figure 2 Typical configuration at the headquarter

The *insurance company* needs contact with the vehicles when damage, accidents or delays occur. In the case of accidents, accurate information about course of events and position is needed for assistance or rescue actions.

For small companies one or more PCs or workstations are sufficient for the handling of messages and acquisition of data, like positions or cargo temperature. For larger companies, a configuration like this is suggested:

A Local Area Network (LAN) is connected to the telex network, X.25/X.400 network or the telephone network through a modem. Messages will be routed to different users in the company based on the message addresses. The position data for each vehicle may be routed to a dedicated PC/workstation running suitable software, like a map monitoring program, and specific data like cargo temperature and status reports for each vehicle may be routed to and saved on a dedicated PC/workstation. We can also imagine access to databases containing customer data, geographical data, ferry timetables, customs information, dynamic information about road accidents and possible rerouting. Such information may be available both to the vehicle and to the headquarters.

## The Sties project

In the spring of 1991 a fleet management test project was started in Norway. Participants were the transport company Sties Termo Transport A.S, Norwegian Telecom and the software developing company Euro Traffic A/S. Sties Termo Transport A.S is one of the leading transport companies in Norway, owning and making use of more than 250 special vehicles for transport of frozen and refrigerated cargo. They operate all over Europe, including Eastern Europe.

In 5 trucks, INMARSAT-C terminals, laptop PCs and GPS receivers were installed. Some of the trucks were also equipped with logging facilities for cargo temperature. Norwegian Telecom provided the equipment and Sties provided the vehicles and drivers. A software package was custom developed by Euro Traffic. This is terminal software for easy operation of the INMARSAT-C terminal more suited for these specific needs than the soft-

ware originally delivered with the INMARSAT-C terminals.

The GPS receivers were set for periodic transmission of positions. At Sties head office, a PC equipped with a large colour display was running map software, where the received positions were displayed for each vehicle. Received messages were routed through Sties' local area network to internal addresses or to a common mailbox.

The experiences gained by this project have been very useful. Feedback has been given by drivers and transport agents, the most important user group at the head office. The software user interface is very important, and all unnecessary functions were removed. A simple user interface for the transmission and reception of messages remains. This user interface of the software was one of the things that had to be adjusted during the project. It occurred that *too many* functions were hidden for the driver. When something went wrong, like a message did not seem to get through, the driver wanted to know a little more about what actually went wrong. The software user interface was adjusted, and the new version included indications like signal level on a scale 1 - 5. The drivers also gained experience making them able to utilise the system better. Problems like low elevation angle, (especially in Norway) can be omitted when parking the vehicle in the right direction and on the right spot.

Also, on the hardware side useful experiences were gained. The cockpit in a vehicle is not too big, and no space is redundant. PCs with hard drives are not made for the rough treatment and temperature fluctuation offered "on the road". Different equipment configurations were tried, and it seems like the PC is the most fragile part. However, PCs specially designed for mobile use are manufactured and currently brought on the market. The drivers participating in the Sties project all had a positive attitude towards new technology and operating PCs. Some were a bit more sceptic to functions like the position reporting, which might have some "big brother watches you" effect. However, this kind of control is also appreciated, taking into consideration the security aspects.

## Concluding remarks

The Sties project has shown that INMARSAT-C, combined with GPS, provides the transport industry communication possibilities no other system can offer. In the USA a report released by the Government Accounting Office in May 1991 reveals that effective Intelligent Vehicle/Highway Systems (IVHS) could reduce travel time in congested areas by up to 50 %, drop petrol consumption by up to 10 % and reduce automobile pollution by up to 15 % (7). Research on IVHS is done on a large scale. These systems are not limited to communication as presented in this paper, but are intended as a total control system for road traffic. This is fleet management in the broadest sense. Satellite communication and navigation offered by INMARSAT-C and GPS, should be very well suited as part of such systems.

## References

- 1 Haga, O J. Mobil satellittkommunikasjon, perspektiver for 90-årene. *Teletronikk*, 3/4, 231-236, 1991.
- 2 Berzins, G et al. INMARSAT: Worldwide mobile satellite services on seas, in air and on land. *Space Technology*, Vol 10, No 4, 231-237, 1990.
- 3 Teunissen, P J G. De geodetische lijn. *De Ingenieur*, nr 6/7, 24-30, 1991.
- 4 INMARSAT. *Standard-C System definition manual*. Release 1.3 July 1989.
- 5 Ekman, A. *A new international position reporting service for maritime and land mobile users*. Paper presented at the U.S Institute of Navigation Satellite Division 2nd international technical meeting, ION GPS-89, September 1989.
- 6 Beltran, J. *Lakseeksperten og informasjonsflyten, satellittkommunikasjon med mobile enheter*. Internotat Sties/Televerket, februar 1991.
- 7 Manuta, L. Intelligent Vehicles, Smart Satellites. *Satellite Communications*, February 1992, 21-24.



# Terminals for mobile satellite communications

BY JENS ANDENÆS

## Introduction

ABB Nera's involvement with mobile satellite communication started in 1968 (then Nera A/S) with a system study report. The product development began in 1975 and the first generation ship earth station was type approved and put on the market 1st September 1978. The market expanded rather slowly in the first years since the equipment was costly in both purchase and usage, and the shipping companies had adapted their way of running the business to unreliable communication using HF radio between the shore based offices and the ships. From the mid-80s the market started to expand more rapidly, and with the expansion of the INMARSAT charter to include aeronautical and land mobile communication, new market segments opened.

ABB Nera is today the largest supplier of INMARSAT stations for the earth segment of the system. This includes mobile stations for INMARSAT A and

INMARSAT C, as well as control stations for INMARSAT A, INMARSAT C and INMARSAT Aero. The majority of the deliveries are export and are in use all over the world.

For the mobile terminal market we are today manufacturing stations for Inmarsat A and Inmarsat C that are used both in the maritime sector and for applications on land.

The market has been characterised by a continuous technical development with price competition and falling prices. This has made it necessary to bring out new product generations approximately every second year to take advantage of new and more cost effective technology, and to develop new services as they become available in the system.

## Mobile stations

ABB Nera is currently manufacturing many different mobile satellite terminals for INMARSAT A and INMARSAT C systems. The stations are all marketed

under the brand name Saturn, and in the following their main characteristics and their applications are described.

## Saturn 3s90

This is the latest version of our series of INMARSAT A stations. The equipment comprises an antenna unit, electronic unit, teleprinter, and a telephone set.

The antenna unit (figure 1) is enclosed in a 1.5 m glass fibre radome with a total weight of 95 kilos. The antenna element is a 1 m parabolic dish mounted on a stabilised pedestal. The antenna needs to be stabilised regarding several different motions, roll and pitch, sudden changes in course, and change in the direction to the satellite due to the ship moving on the surface of the earth. The roll and pitch stabilisation is a passive system that with the aid of two gyro wheels mounted directly on the antenna system, forces the antenna to point in the same direction even if the ship rolls and pitches up to 30 degrees. Sudden course changes are compensated for immediately by using information from the ship gyro compass. The last system is a slow "step track" that gives the antenna small deviations in elevation and azimuth, measures the corresponding small changes in received signal strength and moves the antenna continuously to the direction giving maximum signal strength. At power-up the antenna will, if there is no signal present, scan by itself over the hemisphere and acquire the satellite automatically. If the power to the system fails, the pointing data is stored and when power is resumed, the antenna will go to the last pointing direction to re-acquire the satellite.

The RF equipment consists of two sub-units mounted on the stabilised

621.396.946

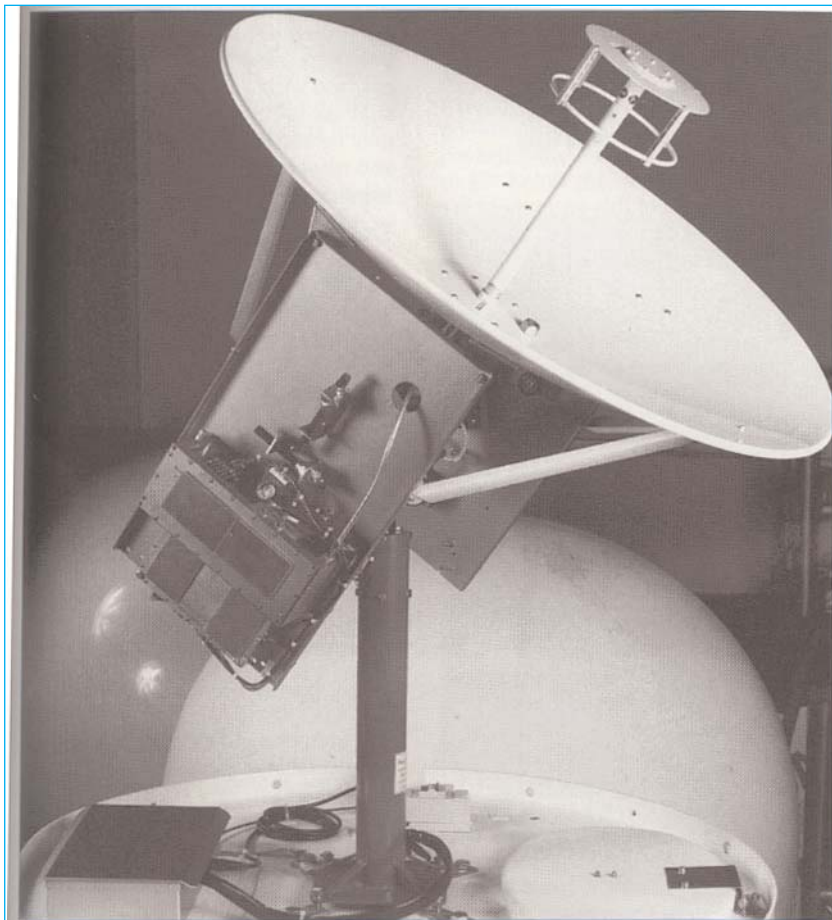


Figure 1 Saturn 3s90 stabilised antenna system with the radome removed



Figure 2 Saturn 3s90 Electronics Unit



Figure 3 Saturn Compact in operation



Figure 4 Saturn Compact ready for operation

antenna system to minimise the loss in the antenna cable. The units comprise duplex filters, low noise amplifier, down-converter, up-converter and a power amplifier with an output power of 25 Watts.

The connections to the electronic unit below decks are via a single screened special cable containing a coax cable and a main cable. The coax cable feeds all necessary control signals between the antenna unit and the electronics unit, such as receive IF, transmit IF, frequency reference for up- and down-converters and supervisory and control signals in serial form.

The electronics unit (figure 2) comprises modulators, demodulators, audio processor, control processor, high stability frequency reference, interfaces for the telephone and teleprinter and power supply.

The telephone interface is standard two-wire with the same levels as in the terrestrial network, to allow the interconnection to standard equipment without special adapters. Call set-up is done in the same way directly from the keypad on the telephone set. Since the station looks like an ordinary branch line, it may be directly connected to fax machines, voice band data modems, or to a PABX if it is required to use the station from several different outlets.

The station is equipped with two separate telephone extensions with its own unique numbers in the INMARSAT system. If a telephone set is connected to one extension, and the fax machine (or a data modem) connected to the other, one has direct in-dialling to the desired extension, it is possible for instance to send fax to the ship automatically at any time with no need for attendance to the equipment on board. Group 3 fax may be sent to and from ships at 9600 bps. The same speed is attainable with voice band data modems.

The prime users of this equipment are generally large ships of all categories, but also trawlers and luxury yachts constitute a major user group. During the last years with liberalisation, a large number of these stations have been placed on land as fixed installations in areas where international communication lines are not available, or difficult to obtain.

For users with the need of higher data rates a new option has been developed that offers 56 or 64 kbits data transmission from the terminal to shore. In the return direction there is at the same time a normal analogue voice channel capable of 9.6 kbit/s. This service is especially attractive for the oil industry for instance sea-bed surveying, or on drilling ships generating large amounts of data that needs to be analysed on shore. Other potential applications may be real time compressed video transmission to experts on shore in conjunction with on-board services and repair, or it could be used for video remote supervision of unmanned installations.

Also under development is an enhancement of the service to full duplex 64 kbits that will be available late this year. This service may be used for data transmission of large data files in both directions, video conferencing using compressed video, or it could be used for multi channel operation using digitally coded telephone, for instance six simultaneous voice channels coded at 9.6 kbit/s.

### Saturn Compact

This station has been developed to meet the rising demand for transportable stations that was created when it became allowed to use stations on land. When the need for communication arises spontaneously, e.g. an earthquake, there is an urgent need for equipment that is easy to transport, quick to put into operation, and above all is easy to use (figure 3). To satisfy this demand Saturn Compact was developed simultaneously with Saturn 3s90, and the equipment is based on the same modules.

All electronics including the antenna is integrated into a custom made rugged polythene case measuring 70 x 60 x 30 cm, and with a weight of 34 kg. The suitcase is equipped with handles so it may be carried by one or two persons, and wheels for easy transportation (figure 4).

The antenna element is a sectioned 90 cm parabola that is packed inside the lid during transport. Under the cover in the main section there are two assemblies mounted on shock absorbers, a waterproof cooling tunnel, and the electronics unit. The RF units and the power supply is mounted on the cooling tunnel, with heat sinks protruding into the air flow generated by a thermostatically controlled fan.

The electronics unit is almost identical to the corresponding unit for Saturn 3s90. The only difference being a slightly different configuration, and the removal of the outer panels since the unit is integrated into a different enclosure.

All connectors to external equipment are available at the exterior of the suitcase protected by a small panel so that the lid can be closed and the equipment left out in all weather conditions after the equipment has been powered up and the antenna has been aligned with the satellite. In this condition the

equipment is rain and splash proof and will operate in a temperature range of -25° C to +55° C (the unit has in extreme cases been operated down to -45° C).

The power supply is universal, and will accept input voltages from 90 to 264 VAC without the need for any manual voltage setting in order to cope with the different voltage standards used around the world. If it is to be operated in places with no available source of energy, then solar panels and battery together with a DC/AC inverter may be used, or a small portable power generator.

Readying the station for operation is a simple task, taking no more than 5 minutes by one person. The antenna is assembled on a universal joint mounted on a small post, using the suitcase as a stable base. Aligning the antenna with the satellite is easily done with the aid of a compass and a map showing the pointing direction for the satellite overlaid a global map. The received signal strength is indicated both on an LCD display, and as the pitch of a beeping tone that may be switched on for antenna alignment. The beam width of the antenna is approximately 14°, so the pointing accuracy is quite modest.

The Saturn CompacT offers the same basic services as the Saturn 390, i.e. two telephone outlets and telex. The telephone lines may be connected directly to fax machines, voice band data modems or PABXs. Users that have the need for encryption may use commercially available equipment for encrypted telephony, telex, data and fax.

Prime users for this equipment has been international organisations such as the Red Cross and various UN organisations operating in areas hit by disaster, or on peace keeping missions. Other users are embassies, corporations operating in countries with poor infrastructure, and news agencies and broadcasters (e.g. Peter Arnett from CNN in Baghdad during the Gulf war).

The 56 or 64 kbit/s services are of particular interest to broadcasters. With new coding standards it is possible to obtain 7.5 and 15 kHz high quality audio connections, from anywhere on the earth, to the studio without having to arrange special lines to the location.

The service may also be used for TV news flashes by coding the video to an acceptable quality (e.g. 768 or 384 kbit/s), storing the data on disk and retransmit the data at 64 kbit/s. A two minute's news flash coded at 384 kbit/s will be transmitted in 12 minutes, which is a large improvement from using a voice band modem that would take 1 hour and 20 minutes for transmitting the same amount of data. The cost of the transmission would also be less than a quarter of the cost using a voice channel and a modem.

### Saturn C

Saturn C is our first generation mobile terminal in the new Inmarsat C system for low data rate message switched services. It is primarily developed for maritime use, and is fully compliant to the requirements of GMDSS (Global Maritime Distress and Safety System). The equipment comprises four main parts; antenna unit, electronic unit, PC, and printer (figure 5). The antenna unit is an integrated unit where the antenna and the RF equipment are enclosed in a waterproof encapsulation, measuring 42 cm high and 12 cm in diameter and with a total weight of 3 kg. The antenna element is an omnidirectional quadrifilar helix, covering the entire hemisphere down to 15° below the horizon. Since the

antenna element is omnidirectional, there is no need for any stabilisation or tracking system in contrast to INMARSAT A terminals. The only requirement is that there is unobstructed sight to the satellite. The RF part comprises filters, low noise amplifier, up and down converters and a power amplifier with an output power of 25 Watts.

The connection to the indoor mounted electronics unit is via a single standard coaxial cable carrying receive IF, transmit IF and power supply.

The functional parts of the electronics unit are modulator, demodulator, control processor, power supply and interface circuits for external connected equipment. All the electronics are integrated into three replaceable sub-units, and the complete assembled unit measures 28 x 7.5 x 26 cm, and weighs only 3.7 kg. There are no controls on the electronic unit, so it may be mounted anywhere indoors. The unit is DC powered and will accept voltages in the range 10 - 33 V. Optional external power supplies are available for AC or combined AC/DC with automatic change-over if the main supply fails.

The system is operated from a PC that may be a note-book PC, or an ordinary desk-top type. For maritime applica-

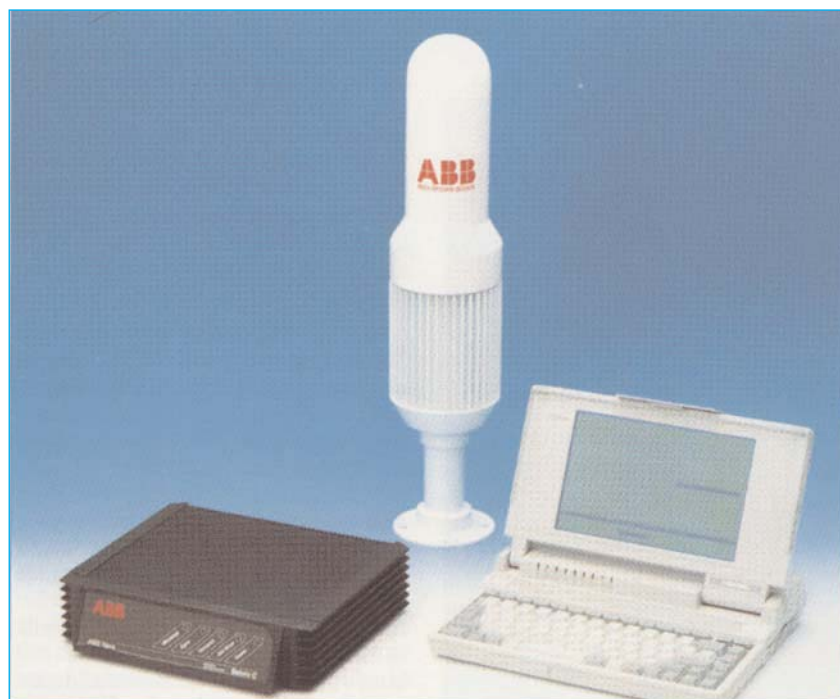


Figure 5 Main parts of Saturn C maritime version

tions where the station constitutes a part of the ship equipment, the PC must comply with GMDSS regarding temperature range, humidity and vibration, and for these applications a note-book PC is used that has been type approved together with Saturn C by INMARSAT. If the terminal is to be used on land, this is not relevant, and in this case other PCs may be used since the electronic unit has a large internal memory that will store any incoming message for later retrieval if the PC is busy with other tasks.

The operator interface is based on pull-down menus, and pop-up windows arranged in a logic and easy-to-use fashion. There are built-in dynamic help screens, that may be called upon via a function key, and continuous updated status messages are displayed at the bottom of the screen to give the operator a good feel for the status of the system at all times. To ease the transmission of messages to recurring numbers, lists are available where the numbers may be stored and recalled when needed. All incoming and outgoing messages are logged in a separate log-file containing the most important data of the call, and its current status (if it is sent, or if it has been received and confirmed by the other part, etc.). The list of coast earth stations in the system is automatically being updated by the system, and may be displayed with information on the available services of each one.

The system is a store and forward system, where the messages are first completed by the user before the transmission starts. The message is then sent to the selected coast earth station that checks the message for any transmission error before it is retransmitted via the terrestrial network to the subscriber. If the transmission contained any errors, these blocks of data are automatically retransmitted. When the message has been delivered to the subscriber, the system will send a confirmation back to the sender if specified. The basic service is telex, but other services are becoming operational such as X.25, data modem connection or leased line for special applications.

As a part of GMDSS, the equipment has a capability called enhanced group call (EGC). This function permits addressing messages to a ship or a defined group of ships based on geographic position, nationality or whether they belong to a predefined group. This makes it possible to transmit gale warnings, that are received only by the ships that are in the affected area. Likewise, it is possible to alert all ships within a certain radius for assistance in case of accidents. This requires that the equipment is continuously updated about its position, which is normally done by connecting the terminal to a GPS receiver via its NMEA 0183 interface, or it may be done manually on the PC. The terminal also has a facility for transmitting emergency messages, including the position of the ship, at the touch of a button that may be remote from the equipment. The emergency message will automatically contain the ship's position in addition to the type of emergency that may be entered manually.

The system has, besides its messaging service, special protocols for polling and data reporting. A typical application for a ship might be to send regular position reports. The terminal is then set up to automatically send position reports to a predefined address at regular intervals, e.g. once per day. The polling and data reporting facility is particularly suited for telemetry applications and control of equipment in inaccessible locations, such as buoys collecting environmental data or on land with e.g. river water level monitoring.

Satellite communication has always been difficult in the far northern regions with geostationary satellite systems, since the satellite is very low on the horizon, and sea reflections interfere with the main signal. Saturn C may be used in a special configuration, using two antenna units placed at different heights together with one electronic unit. If the signal fails with the current antenna, it will automatically switch to the other, and thus enable reliable operation further north than would otherwise be possible.

Although Saturn C is primarily designed for maritime use, it can also be used for land mobile applications such as fleet management of trucks. If the terminal is connected to a GPS receiver it is possible to have the truck's position plotted automatically on electronic charts, and keep track of the trucks. By interfacing the equipment to other sensors measuring container temperature, door locks, etc., one may have continuous knowledge of the truck or the cargo condition.

In addition to the above mentioned applications, the terminal may be used for fixed installations in areas with inadequate communication, where a message switched system may solve the communication needs in a cost efficient way. Since the messages may be sent between the terminals, an electronic mail network may be set up that operates totally independent of the terrestrial network.

### Saturn C Portable

This equipment has been targeted to users that travel to areas with poor communication, but need smaller and less costly equipment and require text based communication. The design philosophy has been similar to Saturn Compact; all necessary equipment is integrated in a rugged shock-proof suitcase measuring 51 x 41 x 21 cm, with a total weight of about 20 kg including antenna, electronics, batteries with charger, PC, and printer (figure 6).

The antenna is a two-element flat micro strip patch antenna, developed at the Norwegian Telecom Research. The antenna has a gain of about 11 dB enabling the output power from the HPA to be reduced from 25 Watts to 2 Watts, with a corresponding 70 % reduction in power consumption during transmission. The equipment



Figure 6 Saturn C Portable ready for use

may be operated without taking the antenna out of the suitcase, since the lid is transparent to the signals. The lid may be locked in any position, and it is equipped with an elevation indication that facilitates the alignment with the satellite. Total time needed for setting up equipment for operation is less than a minute. The beam width of the antenna is 65° in elevation, and 35° in azimuth, which makes the acquisition of the signal a trivial matter.

If the equipment is to be used in a semi-permanent or permanent location, the antenna may be remote from the other equipment and placed outdoors on a small adjustable foot that is also packed in the suitcase. The standard length of the supplied cable is 5 m which is adequate in most cases, but the antenna may be remote up to 100 m using suitable coax.

Power is always a problem with portable equipment that is to be used all around the world, and Saturn C is therefore delivered with a universal power supply that accepts voltages in the range of 90 to 264 VAC, or from external 12 V battery. The built-in power supply also supplies the PC and printer with appropriate power.

### Saturn C Scada

Saturn C Scada is not a single configuration but covers several different variants dependent on the applications. Fixed installations on land may use the same directive antenna unit developed for the Saturn C Portable while applications at sea, for instance on buoys, will use the omnidirectional maritime antenna. The electronics unit is in both cases the same as is used for the maritime applications but with the software adapted to SCADA applications using the polling and data reporting protocols. These protocols performs the transmission of small data packets at a much lower user charge and shorter transmission delay compared to the normal message protocols. This is of great significance for systems that transmits data maybe several times a day for a prolonged time.

The equipment is normally connected to a dedicated controller instead of the PC controlling both data loggers, sensors and the transmission. Controllers are available that conserve the power used by the equipment by switching off the power when idle and activate

the equipment only when data is to be transmitted. This reduces the size and the cost of solar panels and batteries considerably. Saturn C was especially designed with low power consumption in mind and is thus very suitable for these applications.

### Saturn B and Saturn M

These are next generation products that have been under development for over a year and will be put into production next year.

Saturn B is a follow up of Saturn 3s90, and will be developed in both maritime and transportable versions. This is a satellite terminal where all the services are digitised to expand the capacity in the system. The antenna system remains basically the same, and is a stabilised 90 - 100 cm dish. The services are high quality voice coded at 16 kbit/s, fax and data at 9.6 kbit/s plus optional high speed data at 64 kbit/s. The primary users will be the same as for Saturn 3s90 and Saturn Compact.

Saturn M is currently being developed in two variants; maritime and portable. The basic services are medium quality voice coded at approximately 4.1 kbit/s, fax and data at 2.4 kbit/s. The antenna size including radome will be 60 cm for the maritime version. This opens up new user groups that are prevented from using the current generation equipment due to its size. In the maritime sector it can be placed on smaller yachts and fishing vessels, thus greatly expanding the potential market size. A portable variant will have a weight of 9 kg.

The electronics unit for the stations is extremely compact, with the measures of 31 x 21 x 7 cm. An important factor for the reduction in size is an in-house development of ASICs with approximately 600,000 transistors performing most of the critical modem functions.

### Reflections

ABB Nera's results and position in the INMARSAT field are relatively rare in Norwegian electronics industry, especially in a field with strong international competition from Japan and the USA. There are no single factor that is the cause of the success, but rather a set of factors that all contributed to the results. The foundation was made early when both the Norwegian Tele-

com and NTNF realised that satellite communication was the way to go for future maritime communication, and supported the initial developments. There was a large home market in the shipping industry, and we had a background in both developing and marketing communication equipment to the shipping industry. When the development projects were established, it was with a dedicated team with pioneering spirit and the success has come through a continuous strive to utilise available technology to reduce cost and to develop new services and in this way maintaining the competitive edge.

With the current projects well underway for next generation digitised equipment, the basis for a continuous strong position for ABB Nera in the INMARSAT market in the 90s has been made.

# Future systems for mobile satellite communications

BY PER HOVSTAD AND ODD GUTTEBERG

621.396.946

*"Mobile satellite communication services provide communications on the move - however you go (by sea, by land, by air), wherever you go (spanning the world) - with anyone, anywhere and anytime"*  
(Jai Singh, INMARSAT, 1991)

## 1 Introduction

The first satellite system for mobile communication (for ships), MARISAT, was put into operation in 1976. This system was succeeded by the INMARSAT system in 1979. The 1990s will most probably revolutionise the mobile telecommunications services, particularly for personal communication. In this field, satellites will play an important part because of their unique properties: a potential large coverage area and fast establishment of the service.

## 2 INMARSAT

INMARSAT is an international company owned by the member states. The aim is to specify, establish and operate communication satellites for

mobile services. The company's income is made up from hiring out transponder capacity in the satellites.

INMARSAT has 64 member countries, with one signatory per country. The Norwegian Telecom represents Norway, which is the third largest signatory with a share of around 13 %. USA is the largest with 25 %. Denmark and Sweden have only 2 % and 1 %, respectively. Altogether, Europe owns more than 50 %.

At present, INMARSAT has 10 satellites in the geostationary orbit. They cover four areas, see figure 1:

- Atlantic Ocean - East (AOR-E)
- Atlantic Ocean - West (AOR-W)
- Indian Ocean (IOR)
- Pacific Ocean (POR).

The INMARSAT system is made up of four main parts:

- The space segment, comprising the satellites with their control stations (TT&C) and operational control

- The coastal earth stations (CES), which connects the satellite transmission to the national and international telecommunication network
- The Network co-ordinating stations (NCS), which handles the channel allocation in a coverage area
- Mobile earth station (MES), i.e. the user terminal.

The Norwegian coastal earth station is located at Eik, Rogaland. It operates towards the Indian Ocean as well as towards the Atlantic East.

Several different terminal standards are employed in the INMARSAT system, see figure 2. INMARSAT-A has been operative since 1982. It is a relatively large terminal (ca. 1 metre parabolic antenna) which is used for telephony (FM), telex and data. INMARSAT-B, which is the successor, is mainly like INMARSAT-A, but uses digital modulation. This will give a better utilisation of the space segment and thereby lower prices. INMARSAT-M is a smaller and cheaper terminal which uses a lower bit rate for the telephone channel. Aero is a special version for the use in aeroplanes. INMARSAT-C is a low-speed (600 bit/s) data message system based on "store-and-forward technique". The terminals are equipped with small omnidirectional antennas.

The INMARSAT system today has around 20,000 terminals. The number of terminals is expected to increase beyond 70,000 as early as 1993. The development is pointing towards communication with ever smaller units, like cars and people. This is the reason why INMARSAT expects a dramatic increase in the number of terminals, more than a million in the year 2000, figure 3.

## 3 The role of satellites in future telephony

The end user wants required information transferred to a receiver in the most practical way, with highest possible quality and at lowest possible price. The way in which this is done is irrelevant to the end user. Satellite communication is only one means of meeting user requirements, and it is justified only in those cases where this form of communication can compete with other methods.

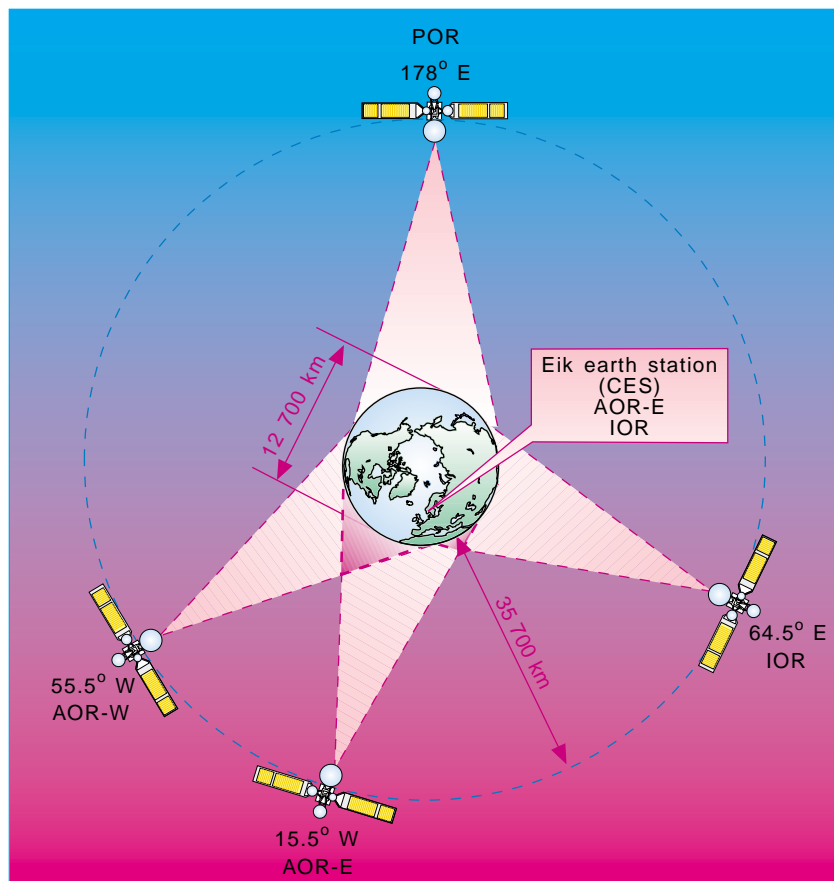


Figure 1 INMARSAT coverage area

	St.A	St.B	St.C	St.M	Aero
Antenna - Type - Steering	0,9 m Parabol Steerable	0,9 m Parabol Steerable	15x15 cm Omni Stationary	30 cm lin.array Az steering	array electronic
Telephony Telex/Data	FM 9,6 kb/s	16 kb/s 9,6 kb/s	- 600 b/s	4,8 kb/s 2,4 kb/s	9,6 kb/s 10,5 kb/s
Cost/terminal	NOK 175 000	-	NOK 35 000	-	ca NOK 1,5 mill
Charge/min	NOK 43 (telephony) NOK 23 (telex)	-	- NOK 20 (telex)	-	NOK 43 (telephony)

Figure 2 INMARSAT services

One evolutionary trend seen today is that the wish for greater accessibility, particularly for telephony, leads to a demand for smaller, mobile terminals. The land mobile telephone network offers connections via terminals integrated in a handset of pocket format. Earthbound cordless networks will be characterised by a relatively small coverage area per base station and the possibility of high capacity through frequency reuse.

On the one hand, satellite networks will be able to offer connections within a much larger coverage area and thereby also possibilities for a more flexible utilisation of the capacity within a given geographical area. On the other hand, satellite networks will have a lower maximum throughput with limited possibilities for frequency reuse. Price per transmission channel will also be much higher for satellite networks.

Development of a network for personal telephony is in its infancy, and will require large investments and a lot of time before it is operational with a significant penetration in the market. In this future network there will be many areas not relevant for developing by

land mobile networks, either because it is technical impossible (oceans, inaccessible/deserted areas) or economically uninteresting (low traffic intensity). Figure 4 shows the expected global coverage area in the year 2000 for land mobile services.

Satellite networks will be well suited as a temporary solution since it can be established in a relatively short time, without major investments on the ground. The large coverage also makes satellite networks attractive for areas where earthbound networks will not be developed for the above reasons. For long distance connections (international) satellite networks will be able to compete with land mobile networks because they can establish a direct connection, or a connection with far fewer relay points.

Whereas land mobile networks are preferable where the demand for traffic is large, satellite systems will have their strength in areas with a lower traffic intensity. It therefore seems probable that both systems will find their places in the future mobile communication concept, and that they will be able to be complementary to one another, rather than fighting for the same market.

#### 4 Requirements for a land mobile satellite system

In order to satisfy the user a set of requirements has to be made to the satellite system. In its turn this will determine the design of the system:

- 1) User terminals should be mobile, reasonably priced, small and light-


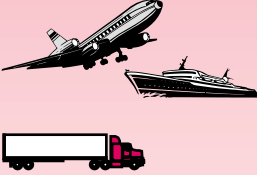

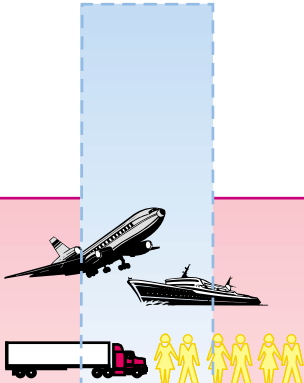
Market				
Number of terminals	1,500	18,000	73,000	1 Mill
Services	A	A, C, Aero	A, C, M, B, Aero	A, C, M, B, Aero, Navigation Paging, P
Year	1982	1991	1993	2000

Figure 3 Development of INMARSAT services

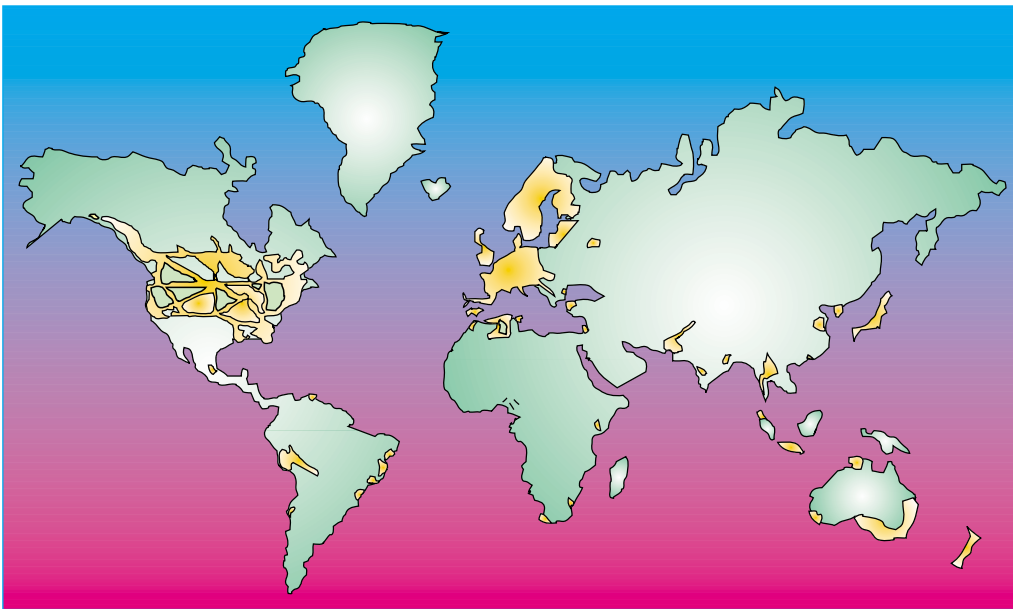


Figure 4 Coverage areas of land mobile services (yellow) in year 2000

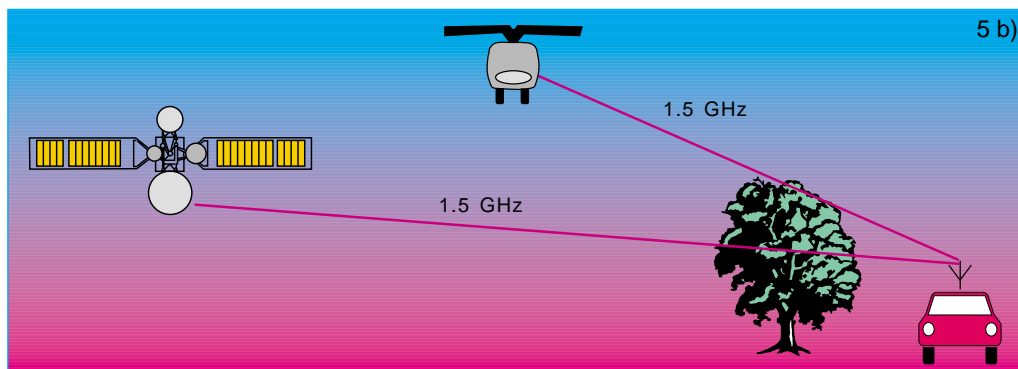
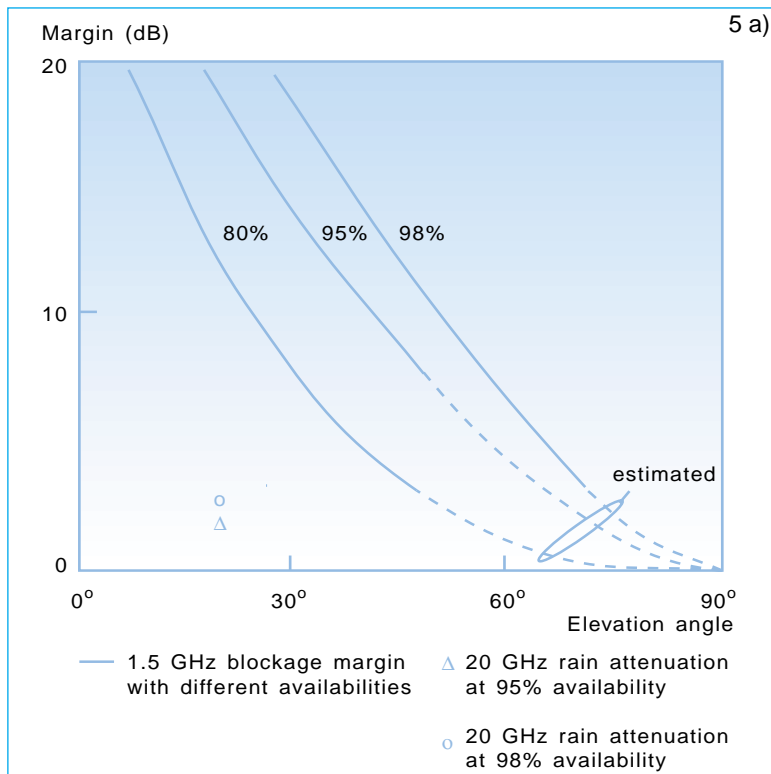


Figure 5 Blockage margin for different availabilities as a function of elevation angle, figure 5 a). The model is based on satellite measurements and measurements with helicopter. The measuring set-up is shown in figure 5 b) (Ref. University of Texas)

weight. Terminals without directive antennas are also desirable.

- 2) The system should have good accessibility; low probability of blocked calls and little loss of calls
- 3) The quality of the connections should be comparable to that of the present stationary ground network.

If the system is to be realised with handheld terminals there will, for safety reasons, be an upper limit for allowed radiated power. Battery capacity and requirements to active time, will also limit the output power. From these criteria the output power should be in the area of 1 - 2 Watts.

A handheld terminal should not be dependent on pointing the antenna to the satellite. This means that the terminal must be equipped with an approximately omnidirectional antenna, i.e. 0 dB antenna gain. An omnidirectional antenna will have a fairly large noise temperature due to the thermal noise from the earth.

Supposing a system noise temperature of 240° K the specifications for a "typical" user terminal will be:

$$\text{EIRP}_{\text{up}} = 0 - 3 \text{ dBW}$$

$$G/T_{\text{down}} = -24 \text{ dBK}^{-1}$$

The system's availability is an important parameter. Blockage of the signal because of trees, buildings, etc., will for a large part of the time make communication difficult. Figure 5 shows necessary blockage margin for different availabilities as a function of the elevation angle. In order to operate with a reasonable margin, the elevation angle for a mobile satellite system should exceed 30° according to this model.

The time delay introduced a geostationary satellite connection is approx. 1/4 second each way. For telephone connections this is experienced by many people as a major reduction in quality. For other types of communication this is also undesirable, since special solutions often must be employed for taking care of this time delay.

## 5 Techniques to meet user requirements

Traditional communication satellites consist of transparent transponders where the signals are amplified and shifted in frequency before they are



transmitted back to earth. Usually there are input and output multiplexers, comprising mechanical switches for connecting redundant circuits in the case of faults, and to a certain degree enable cross connections between different up- and down-links.

In the following we will present some relevant techniques, which to a certain extent may be used to improve and increase the efficiency of the traditional satellite connection.

### 5.1 Satellite orbits

The fact that a satellite in the geostationary orbit, as seen from the earth, is fixed, has of course great advantages for many applications, but this does not exclude other satellite orbits from having advantages. A disadvantage of geostationary satellites is the fact that they render poor coverage of the northern and southern areas, see figure 6. In addition to the geostationary orbit, there are mainly two types of orbits which are relevant candidates for telecommunication purposes: low earth orbits and elliptical orbits, see figure 7.

Orbiting satellites have to avoid the earth's atmosphere, in order to prevent friction and damage from colliding with particles in the atmosphere. These effects are of significance up to a few hundred kilometres, i.e. the height of the satellite orbits should be greater.

Around the earth at equator there is an area of strong radiation; the van-Allen belts. These belts consist of electrically charged particles, mainly protons and electrons, and are located approx. 0.2 to 7 earth radii above the equator. The high energy protons are at a maximum level around a distance from the earth of 5,000 km, while the electrons have two maxima, one around 5,000 km and one around 25,000 km. These two maxima are denoted the inner and the outer van-Allen belts.

Moving into an area where the satellite is exposed to particle collisions, may damage the satellite and reduce its performance and lifetime. The satellite will be particularly at risk when moving through the inner van-Allen belt, where it will be exposed to collisions with particles with an energy of several hundred million electron-Volts. For satellites injected into geostationary orbit it has been estimated

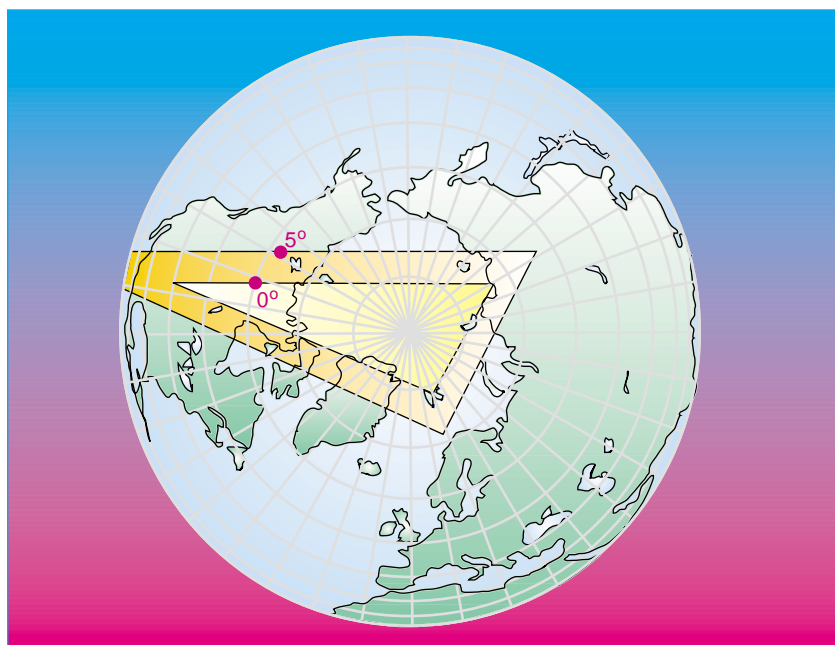


Figure 6 Polar coverage for different elevation angles. Satellites located at  $26^\circ$  West,  $63^\circ$  East and  $180^\circ$  East

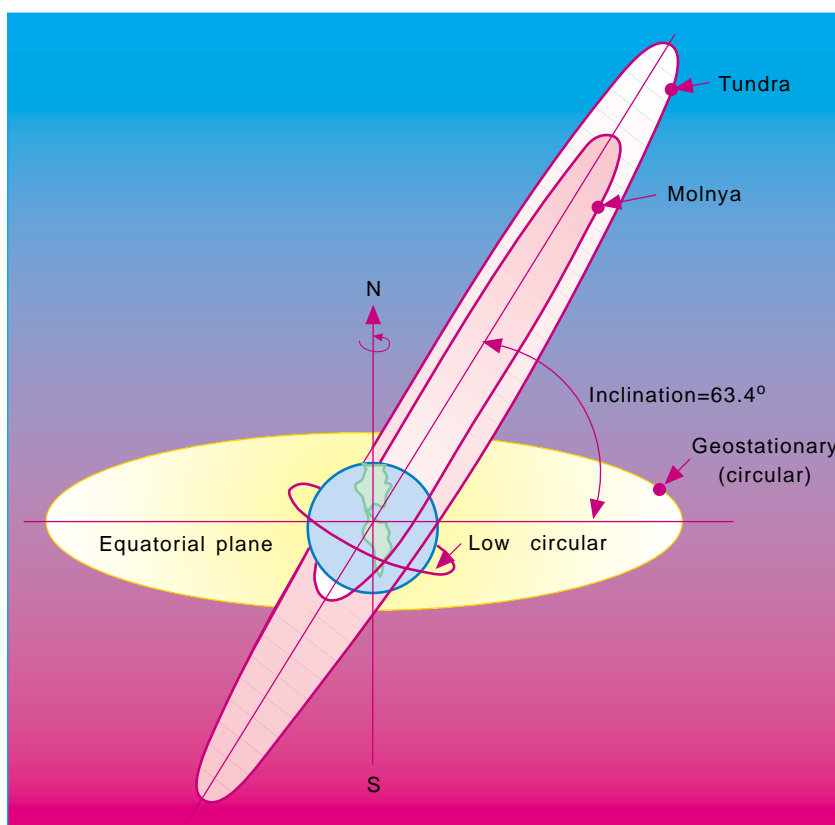


Figure 7 Different satellite orbits

that the power from the solar panel is reduced by up to half a per cent per revolution in the transfer orbit.

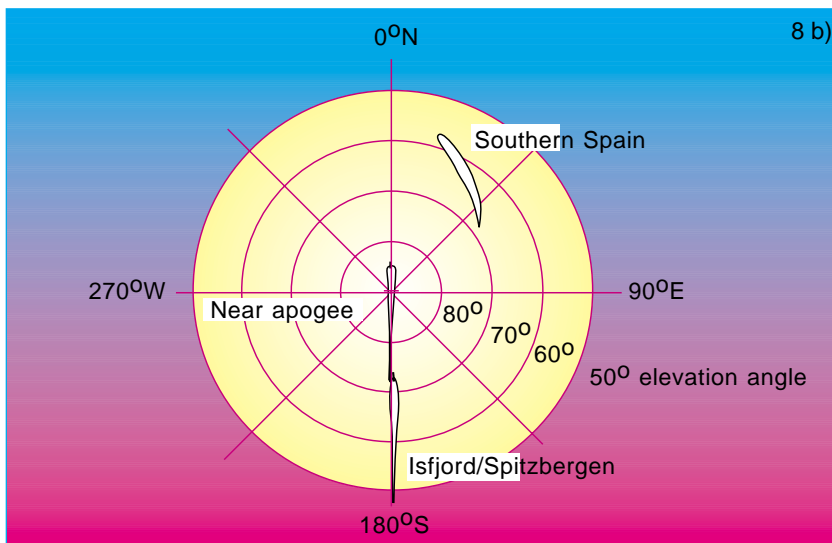
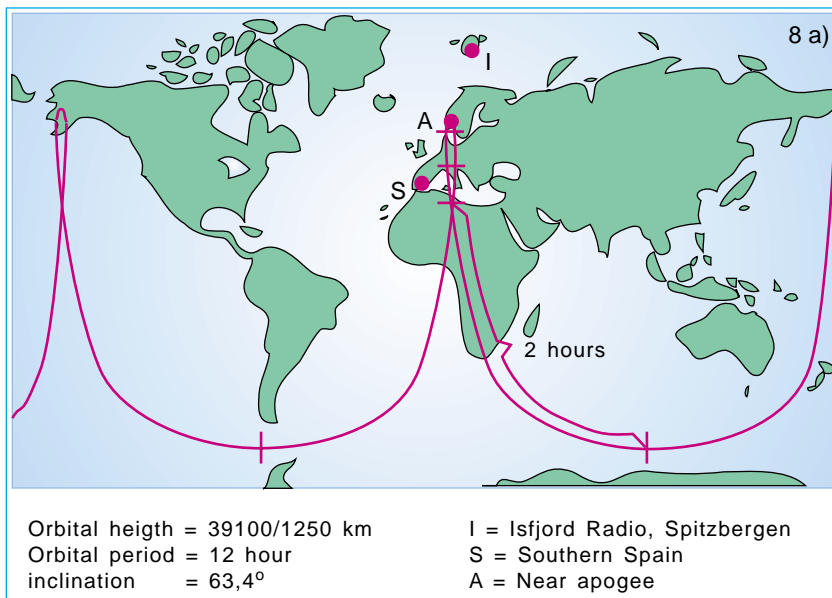
Even if it may be possible to design satellites that are better protected against particle collisions, it is clear that satellite orbits should avoid at least the inner van-Allen belt.

### 5.2 Elliptic orbits

One result of using satellites in elliptical orbits is the fact that the satellites become quasi geostationary around

their apogee for a period of time. By using several satellites in the same orbit, one can make sure that one satellite is at any time visible within the area acceptable for communication.

By choosing wanted inclination, coverage areas with a very high elevation angle can be realised, wherever it may be wanted. This is an attractive quality, particularly for mobile communication and for communication in the northern areas. The fact that the satel-



**Figure 8**  
 The Molniya orbit. The track is shown in figure 8 a). The view-angles towards the satellite for 8 hours around apogee are shown in figure 8 b) for different locations

these, and the problems of particle collisions are therefore considerably reduced. As for MOLNIYA, the inclination is 63.4°.

The radial velocity of the satellite is less in the utilised part of the TUNDRA orbit than in the MOLNIYA orbit (an even number of satellites is assumed). Thus the TUNDRA orbits will give fewer problems with doppler shift than MOLNIYA. The radial velocity, which causes the doppler shift, will be reduced from 2,600 m/s to 600 m/s with a constellation of three satellites.

The ground track of a TUNDRA orbit is shown in figure 9, as well as azimuth and elevation angles for the same three earth station locations as for MOLNIYA. Revolution period of the satellites is 24 hours. If three satellites are employed, even here, Europe will experience satellites also in TUNDRA orbits with an elevation angle of at least 50°, for the duration of the satellite's life.

For transmitting speech and data the high elevation angle will be particularly attractive for mobile communication, while the special coverage areas are interesting for all types of communication. However, the distance out to the satellite is comparable to that of geostationary satellites, and nothing is gained with respect to free space attenuation.

Before systems for satellites in elliptical orbits may be put into operation, systems based on low earth orbit satellites will also be available. Therefore, to what extent elliptical orbits will be used for speech/data transmission is uncertain, due to the advantage of low earth orbit satellites with respect to time delay and free space attenuation. However, in order to realise regional/national systems, elliptical orbits may be an alternative to low earth orbits.

### 5.3 Low earth orbits

Low earth orbits have a radius considerably smaller than the geostationary one. Motorola's planned system IRIIDIUM has a distance from the earth of approx. 765 km, in contrast to the geostationary orbit distance of 36 000 km. When the distance to the satellite is reduced so drastically, great gains are achieved in the link budgets: The difference in free space attenuation to a

lites are not over equator makes it possible to realise single hop connections to areas on the same hemisphere that otherwise would be inaccessible. One could for instance imagine a direct connection between Oslo and Alaska with the help of satellites in elliptic orbits.

Because of irregularities in the earth's gravitational field, an orbit with an inclination of 63.4° is the only one which does not lead to a drift of the perigee. Satellite in orbits using this inclination will therefore consume little fuel for orbital corrections. For communication in Scandinavia this is a very favourable inclination, and the use of elliptical orbits should therefore be better suited to Scandinavia than many other areas.

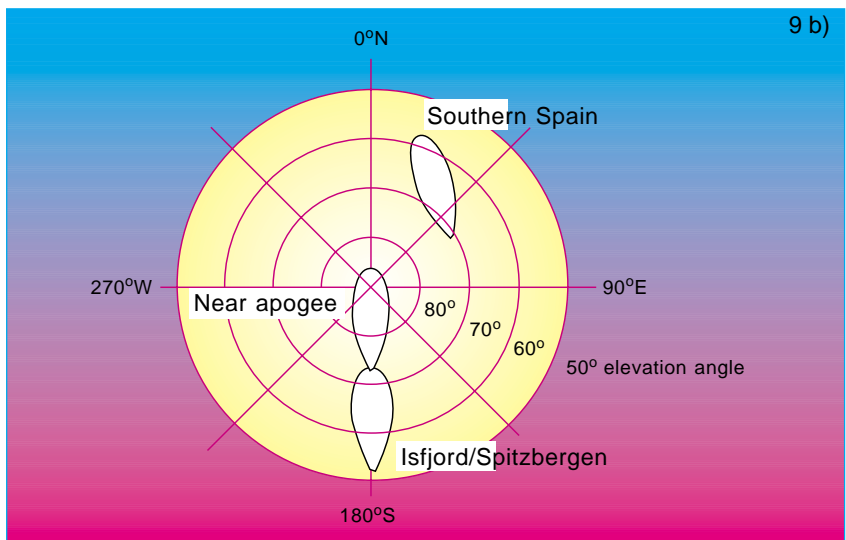
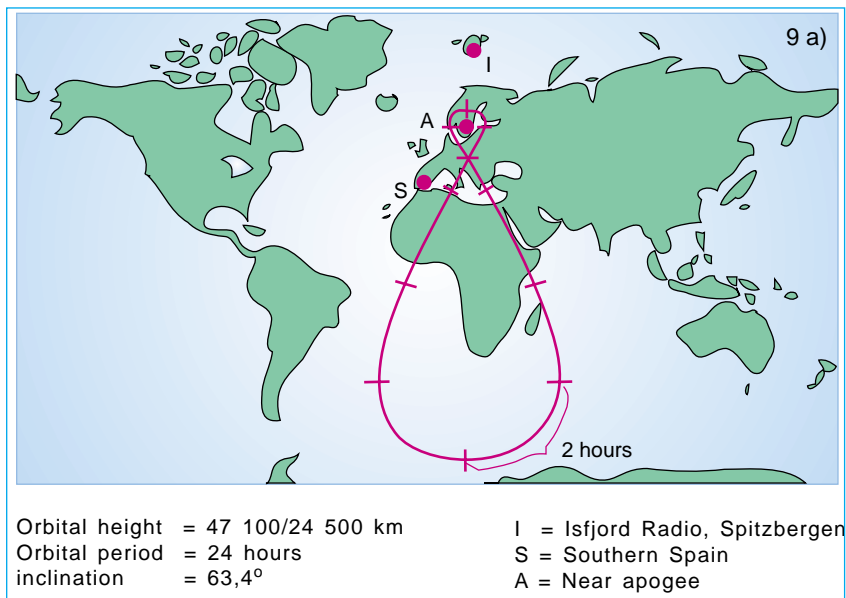
In particular there are two orbits which are most interesting: The MOLNIYA orbit with an revolution period of 12 hours, and TUNDRA with a 24 hours revolution period. The LOOPUS study in Germany which looked into concepts for mobile communication, concluded with a solution consisting of satellites in MOLNIYA orbits, while ESA's ARCHIMEDES study assessed

the use of both MOLNIYA and TUNDRA orbits for mobile communication and sound broadcasting.

The MOLNIYA orbit has a perigee height of 1,250 km and an apogee height of 39,100 km with an inclination of 63.4°. Figure 8 shows the ground track (track of sub-satellite point) of a MOLNIYA orbit where the apogee point is located at 15° E. Furthermore, azimuth and elevation angles for three different locations of earth stations are shown. If three satellites in a MOLNIYA orbit are used, with an angular spacing of 120°, the whole of Europe would see the satellite with a minimum elevation of 50° (Spitzbergen included) for eight hours around apogee. Because of the revolution period being 12 hours, it will pass over the northern hemisphere twice per day, separated 180°. Such a system could for example be utilised both in Scandinavia and in Alaska, see figure 8.

A disadvantage of the MOLNIYA orbits is the fact that they cross the van-Allen belts twice per revolution. The TUNDRA orbits with perigee and apogee heights of 24,500 and 47,100 km respectively, is passing outside

**Figure 9**  
The Tundra orbit. The track is shown in figure 9 a). The view-angles towards the satellite for 8 hours around apogee are shown in figure 9 b) for different locations



geostationary satellite and to an IRI-  
DIUM satellite will from Oslo be  
approx. 33.5 dB. This means that if  
you transmit with 0.1 W to an IRI-  
DIUM satellite, you would have to use  
220 W towards a geostationary satel-  
lite in order to reach the same flux  
density at the satellite.

For speech communication the time  
delay of 1/4 second for a geostation-  
ary hop is by many people consid-  
ered a major reduction in quality. In the  
low earth orbit concepts this problem  
is avoided because the distance to the  
satellite is negligible. The low orbiting  
height makes launching less expen-  
sive, and puts fewer requirements on  
rockets and launching facilities.

Since the satellite is so close to earth  
it will only be able to cover a small area,  
and only for a short period of a time  
(in IRIIDIUM, where the revolution  
period for the satellite is 100 minutes,  
each satellite will cover an area for 9  
minutes at the most). In order to  
obtain continual coverage of an area,  
a large number of satellites is necessary.  
IRIDIUM is a global system consisting  
of 77 satellites in 7 polar orbits, see  
figure 10. Polar orbits (90° inclination)  
do not necessarily provide the best  
coverage for Norway. A simulation of a  
system consisting of 77 satellites at a  
distance of 1,000 km shows that the  
inclination giving the highest elevation  
in Norway is around 70°, see figure 11.

Another possible low earth orbit con-  
cept is shown in figure 12a. A circular  
orbit is assumed with an orbital height  
of 1,000 km and an inclination of 63.4°.  
This orbit will have a revolution period  
of approx. 1 hour 46 minutes. The  
coverage area for a given position is  
shown with elevation angles of 0°, 10°  
and 30°. With 72 satellites in 6 planes,  
areas as far as Spitzbergen will be  
covered with an elevation of minimum  
10°, and all "civilised" areas of the  
globe with an elevation angle of mini-  
mum 25°. Figure 12b shows the cover-  
age radius as a function of minimum  
acceptable elevation angle for orbital  
heights of 500, 1,000 and 1,500 km.

The fact that the satellites move  
across the sky creates problems and  
increases the cost for systems based  
on earth stations with directive anten-  
nas. For terminals with approximately  
omnidirectional antennas, however,  
this is not a problem. Certainly, some  
of the gain in the link budget in rela-  
tion to geostationary satellites will be

eaten up by the lower antenna gain,  
but one is still left with a 10 - 20 dB  
net gain per link in relation to geostation-  
ary satellites. Omnidirectional anten-  
nas are also necessary for realising  
handheld terminals.

Hence, low earth orbiting satellites are  
well suited for systems with a large  
(global) coverage area and for termi-  
nals with approximately omnidirec-  
tional antennas, i.e. mobile terminals.  
The terminals will also profit on the  
lower power consumption with these  
orbital constellations.

The fact that the time delay is avoided,  
makes low earth orbit satellites attrac-  
tive for all applications where this is an  
inconvenience. In order to increase  
the quality of speech communication,  
and to enter into competition with opti-  
cal fibres in long distance telephony,  
low earth orbit satellites may be a pos-  
sible way to go. However, it seems like  
this application is still a few years into  
the future.

#### 5.4 Multi-beam antenna

To cover an area on the earth with a  
high flux density and at the same time

enable low transmitting power from  
the terminal, it is necessary to use  
several antenna beams in the satellite,  
see figure 13. Such a concept also en-  
ables frequency reuse. One disadvan-  
tage is that the payload increases in  
complexity.

7, 19, 37 or more beams may be utili-  
sed in such a cell structure, depending  
on the beam width and the minimum  
elevation angle. IRIIDIUM uses 37  
beams.

#### 5.5 Inter-satellite link

Due to the restrictions of weight and  
volume of the satellite, the capacity  
and the number of beams one can or  
wants to realise in one and same satel-  
lite, is limited. If one wishes to increas-  
e the performance of a system bey-  
ond this, one have to use more satelli-  
tes. Today, communication via satellite  
utilises up- and down-link in the same  
satellite. This limits the advantage of a  
multi-satellite constellation considera-  
bly, as each satellite can be regarded,  
isolated from the other satellites in the  
system. By establishing links directly  
between the satellites (ISL), it will be  
possible to have access to the capacity

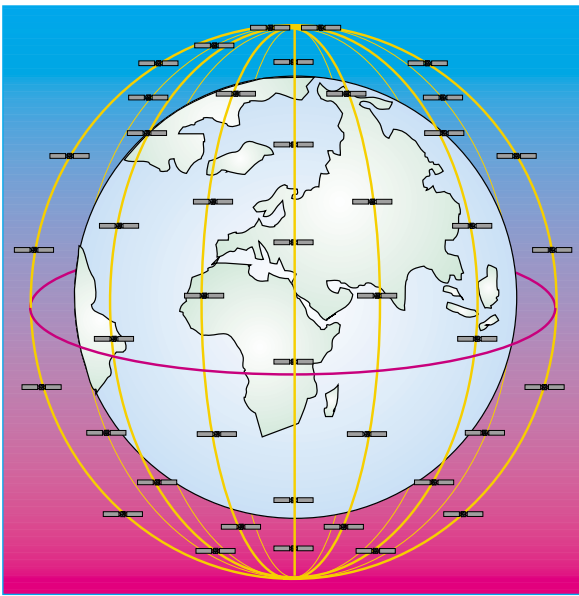


Figure 10 The Iridium System  
77 low earth orbiting satellites. Inclination = 90° and orbital height = 765 km  
(Number of satellites is later reduced to 66)

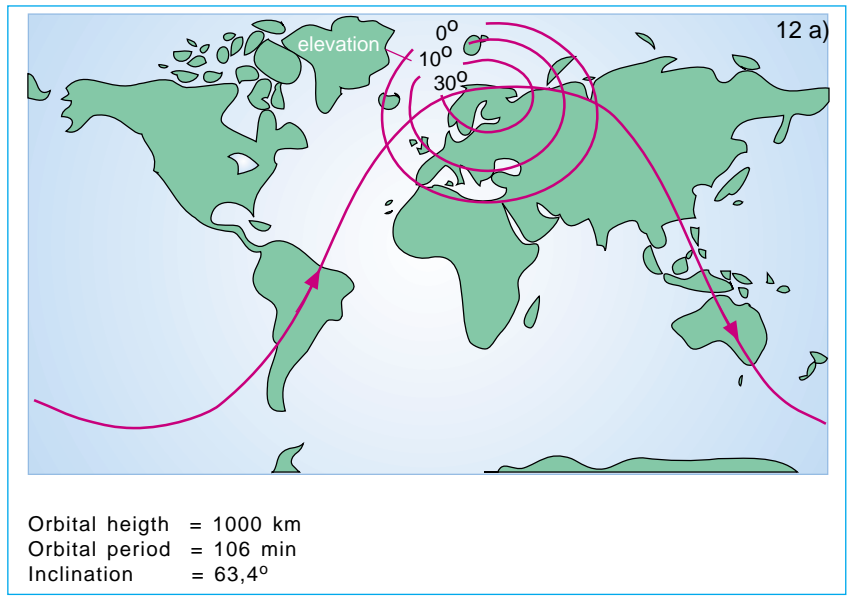


Figure 12 a) Coverage areas for different elevation angles for a given satellite position. The track of a low earth orbit

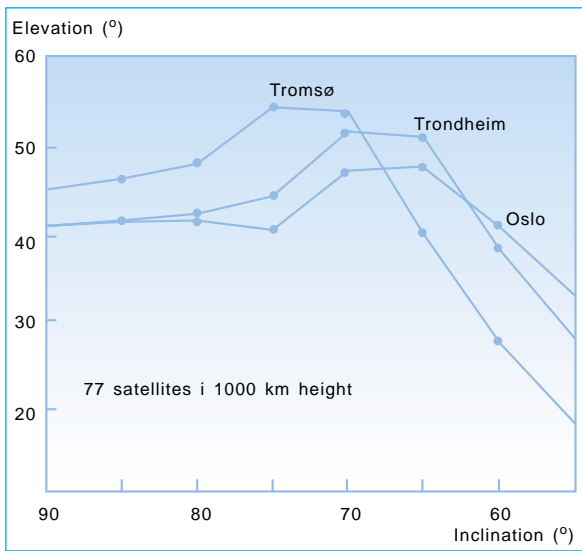


Figure 11 The elevation angle for 50 % of the time as a function of inclination, assuming 77 satellites with an orbital height of 1,000 km (ref. Ellen Lystad, NTH, 1992: Orbital Program: CEBAN)

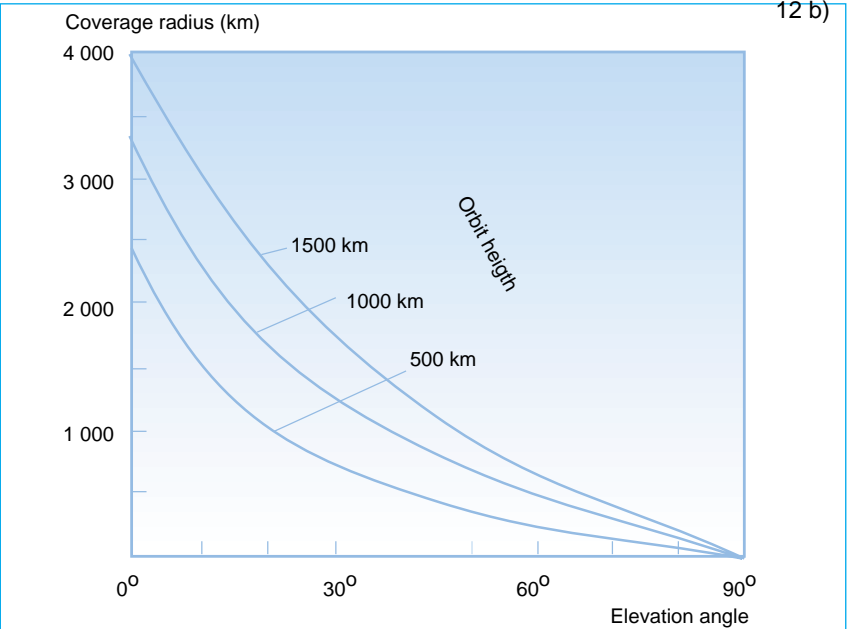


Figure 12 b) Coverage radius as a function of elevation angles for different orbital heights

(bandwidth, effect and coverage area) for all the satellites in the system, without having to be connected via an extra earth station (double hop).

As ISLs have no problem with the atmosphere, such links are usually assumed realised at high microwave frequencies (23 or 60 GHz) or in the optical area.

As far as known, ISLs are today not implemented in any network of satellites, but as switching in satellites becomes widespread, it seems natural that this technique will be used, not only for switching between beams towards the earth, but also for switching beams between satellites.

In the IRIDIUM concept ISLs are used between the 66 low earth orbiting satellites. The satellite that is nearest

the terminals will take care of the up- and down-link. According to Motorola, this system is meant to render a global mobile telephone coverage in the last part of the 1990s. The first satellite in the system is to be launched in 1994.

ESA is working with ISLs in their research programmes and will probably, in some of their satellites in the future.

### 5.6 On-board processing

When using on-board processing (OBP), all up-links in the satellite are regenerated and switched in an ordinary switch-matrix, before the signals are distributed to the various down-links. In this way a full separation of up- and down-link is achieved, and functions like bit rate changes and more down-links per up-link etc., can be implemented in the satellite.

OBP is a good technique in a mobile satellite system where multi-beam satellites and ISLs are utilised. Today the technique is not implemented in any satellite, but several companies are considering to include this in future satellites.

OBP is a relatively new technique, even if the idea is well-known ("switchboard in the sky"). Because of the many advantages that OBP brings along, perhaps the most important being the great simplification of the earth segment and the effective and flexible utilisation of the space segment, it is most probable that OBP, in some form or other, will be seen implemented in even more space segments in the future.

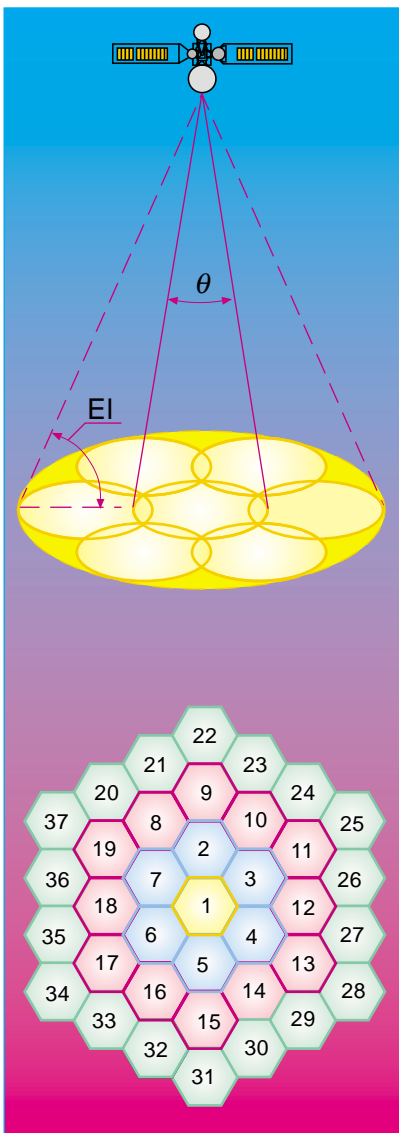


Figure 13 Coverage of a multibeam antenna ( $\theta$  = beam width, EI = minimum elevation angle in coverage area)

### 5.7 Small satellites

Modern geostationary communication satellites usually weigh more than one and a half ton and cost more than NOK 1,000 mill. From the moment the decision is made to build a new satellite until it is launched, a time of five to ten years typically elapses. Because of the large investment per launch it is important to minimise the risks of the launch. This result in using well tested technology in the design. The long time span from planning to launching of a satellite leads to new geostationary satellites being launched with ten to fifteen years old technology in the equipment on board.

In order to realise satellites with more up-to-date technology in the payload, the time from idea to launch, and the risk involved with each launch, must be considerably reduced. One way of achieving this is to use small satellites. These may be produced at a fraction of the cost of a large satellite, and much faster. A 50 kg satellite can be

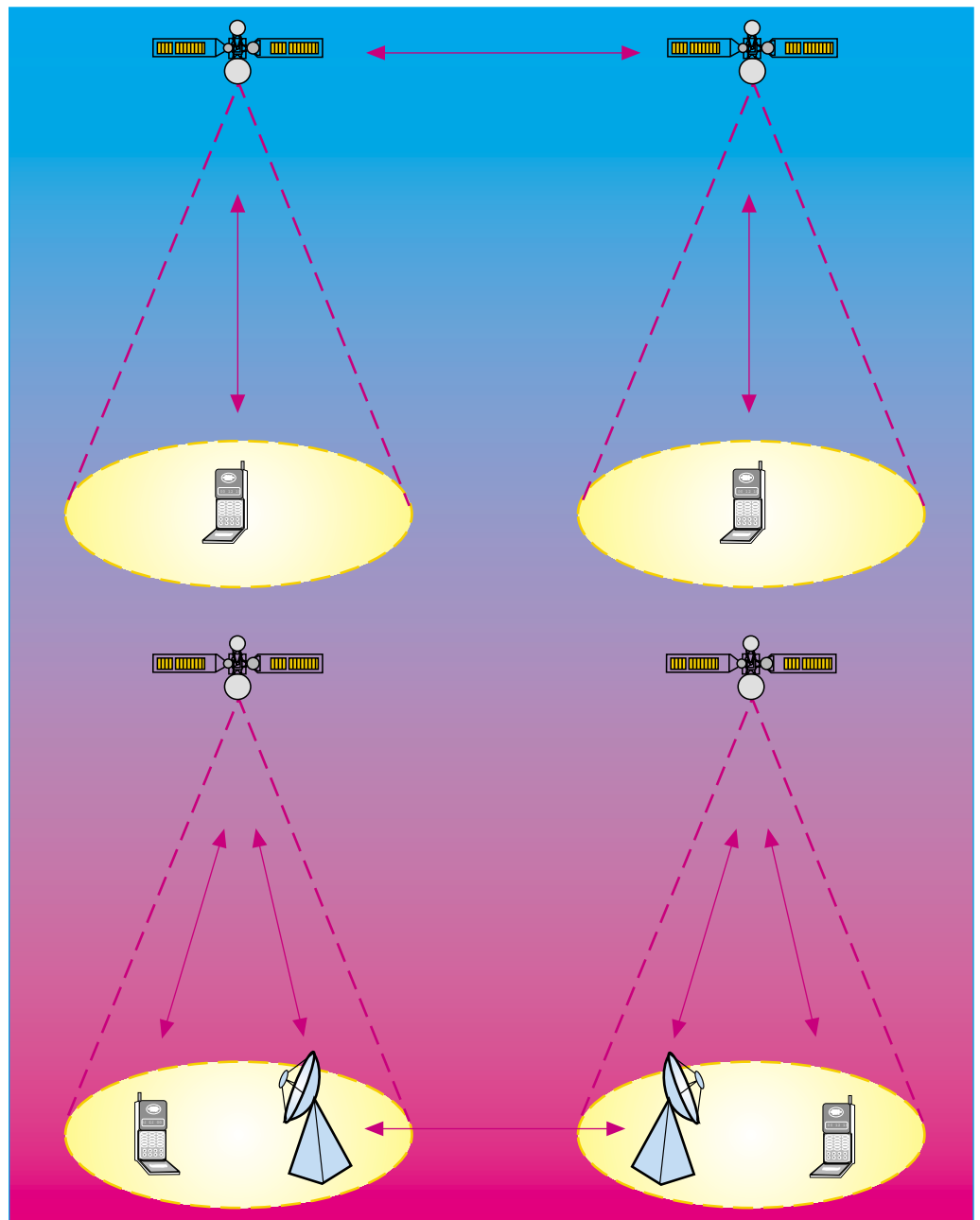


Figure 14 Different network concepts

produced at approx. NOK 10 mill., and Motorola's production of the 386 kg IRIDIUM satellite is estimated to cost around NOK 100 mill., including launch.

It is obvious that the transponder capacity that may be put into such a small satellite is limited (one IRIDIUM satellite can handle max. 6,400 simultaneous two-way telephone channels with the mobile units), but the possibilities of implementing new technology and more sophisticated solutions compensate for some of this. In the low earth orbit concept where each satellite covers a small area for a fraction of time, the need for capacity is limited, and it is here that the flexibility of small satellites has its full effect due to the inexpensive launch.

The simple and inexpensive production and launch make small satellites

suitable also for other special purposes. National/regional tailor-made systems, often based on satellites in a non-geostationary orbit, could be realised without any major organisation or large investments.

## 6 Network concepts

In traditional mobile satellite networks, most of the traffic is between a mobile terminal and a terminal (telephone) in the public network. With the market potential that seems to be present for land mobile satellite terminals, new systems have to be designed also for communication between two mobile units. A considerable amount of traffic is expected to be of this kind.

There are mainly two network concepts which may be used for connecting two mobile terminals:

	Number of sat.	Orbits	Heigth (km)	Weight (kg)
IRIDIUM	77	7 polar	765	380
ARIES	48	4 polar	1000	125
GLOBALSTAR	24/48	8 incl. 52°	1390	230
ELLIPSO	24	4 incl. 63°	2900x425	
ODYSSEY	12	3 incl. 55°	10 600	1125
Project 21 (INMARSAT)	—	Orbits not decided	—	—

Figure 15 Planned satellite systems for mobile telephony

- Telephony, paging, localisation and data services
- Weight < 0,5 kg
- Volume < 0.5 litre
- Output power < 1 watt
- Price < NOK 7000

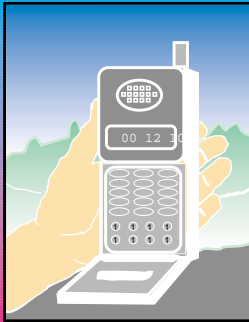


Figure 16 Preliminary specifications of an INMARSAT-P terminal

- The traditional method is connection in the ground network, as shown in figure 14 (bottom). All traffic from mobile terminals is directed to a gateway station. This station establishes further connection through the ordinary telecommunication network. If it is a mobile-to-mobile link, a second gateway-to-mobile link must also be established in one of the following ways:
  - from the same gateway to the same beam
  - from another gateway to the same satellite, but in another beam
  - from another gateway to another satellite.
- A more efficient method for this type of communication is to use a satellite network, as shown in figure 14 (top). Traffic is switched directly to the other mobile unit, either in the same satellite, or in another satellite via inter-satellite links. Traffic to terminals in the public network is routed via the most conveniently located gateway station with respect to the terminal in the public network. The method has obvious advantages by its efficient utilisation of satellite capacity and the minimisation of satellite hops and other connections. At the same time the method requires new satellite types, which may involve a higher risk and great developing costs for an initial period.

Such a network concept has the advantage that large gateway stations can compensate for the small mobile terminals, in order to satisfy the overall requirements to reliability. Such a concept may also be realised with traditional satellites at a low risk. For communication with a terminal in the ground network this concept will work satisfactorily. For mobile-to-mobile links the concept will occupy unnecessary capacity and double hops are inevitable. In the worst cases triple hops may occur if the gateway stations, of which there may be many hundreds, are connected to the public network on a too low level in networks hierarchy.

## 7 "Project 21"

During the last years several suggestions have emerged for concepts using satellites in low earth orbits for mobile communication. A summary of some of the planned systems is shown in figure 15.

INMARSAT is also planning a satellite system for hand portable terminals. This system has the preliminary name Project 21 - "a vision for the 21st century". The main specifications for the handheld terminal are given in figure 16. A discussion of strategy is currently taking place, and the main para-

eters of the system are still to be decided. The system is planned to be operational in 1998.

For 30 years ago the first "real" telecommunication satellite - the Telstar - was launched. At that time it represented a tremendous technological advance. It should be noted that this satellite was orbiting in what we today call a "low earth orbit". The wheel has come to a full circle!

# Effects of atmosphere on earth-space radio propagation

BY ODD GUTTEBERG

## 1 Topic

The growing demand for transmission capacity has forced the satellite telecommunication systems to use frequencies above 10 GHz. Systems are now operating at 11/14 GHz, and the utilisation of 20/30 GHz frequency band is being planned. At these frequencies the radio waves will suffer degradation through the non-ionised part of the atmosphere, i.e. the troposphere. Particularly dominant is the attenuation and depolarisation due to rain and wet snow. In the high-latitude part of the Nordic countries, additional problems arise due to very low elevation angle to geostationary satellites.

All these factors contribute strongly to the design criteria for satellite systems, such as

- localisation of earth stations
- r.f power requirements
- antenna sizes
- capacity requirements, etc.

and the technical solutions to be used.

Our main goal in designing satellite systems, is that all offered services must have the quality and reliability the customers want.

This paper deals with the different aspects of slant path propagation problems encountered in high latitude regions, i.e. elevation angles less than 20 degrees, and frequencies above 10 GHz.

## 2 Introduction

Normally a satellite transmission link is down-link limited. Accordingly, the important equation in designing satellite systems is:

$$\left[ \frac{C}{N} \right]_{down} = EIRP + \frac{G}{T} + \frac{1}{k} + \frac{1}{B} + L_o + L_a \quad (1)$$

where

- $EIRP$  = Satellite effective isotropic radiated power
- $G/T$  = Earth station "figure-of-merit"
- $k$  = Boltzmann's konstant
- $B$  = Transmission bandwidth
- $L_o$  = Free space loss
- $L_a$  = Additional loss

All terms expressed in dB.

The time varying parameters are the additional loss ( $L_a$ ) and the earth station system noise temperature ( $T$ ). Earth station antennas without tracking will also have a decrease in gain ( $G$ ) due to variations in angle of arrival.

The major tropospheric propagation factors that will influence satellite communications are;

- absorption due to atmospheric gases
- radio ray bending due to the decrease in refractive index with height
- scattering due to atmospheric turbulence
- attenuation due to rain
- depolarisation due to rain and snow
- radio noise due to attenuation in gases and rain.

Basic considerations and reviews are found in [1-4]. In the following chapters measurement of the different effects will be presented, bearing in mind the system planners' need for prediction models.

## 3 Atmospheric absorption

Radio wave absorption is due to gaseous constituents in the atmosphere, primarily water vapour and oxygen.

In order to calculate the total slant path attenuation, we need the specific attenuation ( $\gamma$ ), and the equivalent

height ( $h$ ) for water vapour and oxygen, see figures 1 and 2.

According to CCIR [4] the equivalent heights are;

$h_o = 6$  km for oxygen for frequencies below 50 GHz

$h_w = 2.2 - 2.5$  km for water vapour in the frequency range 10 - 20 GHz

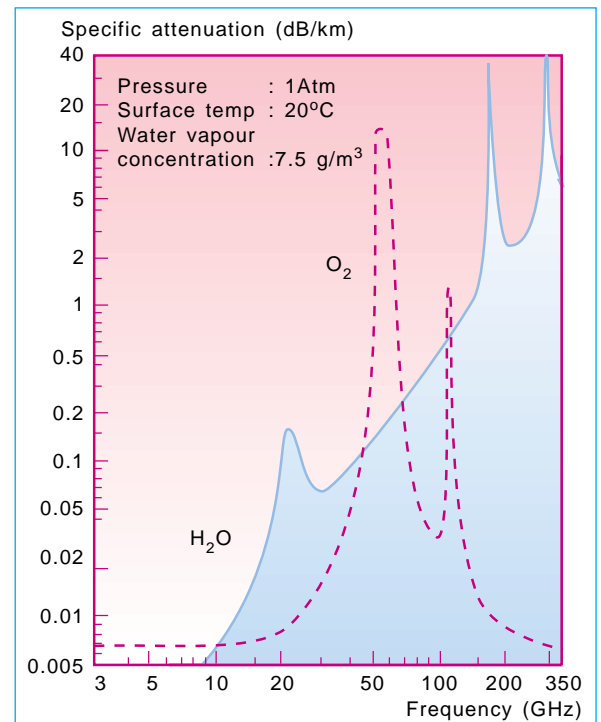


Figure 1 Specific attenuation due to oxygen and water vapour in the atmosphere [1]

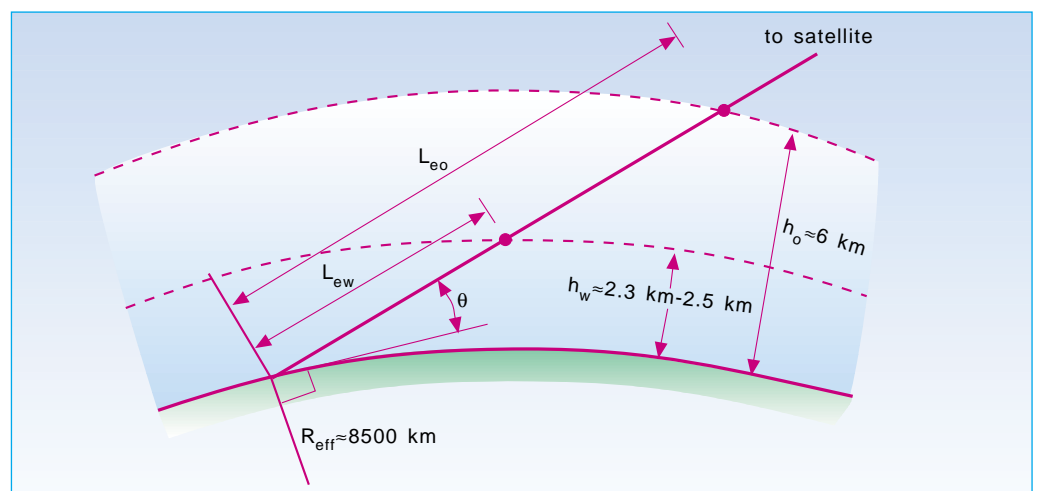


Figure 2 Parameters for calculating the total slant path atmospheric absorption  
 $\theta$  = elevation angle  
 $h$  = equivalent height of water vapour ( $h_w$ ) and oxygen ( $h_o$ )  
 $R_{eff}$  = effective earth radius = 8,500 km

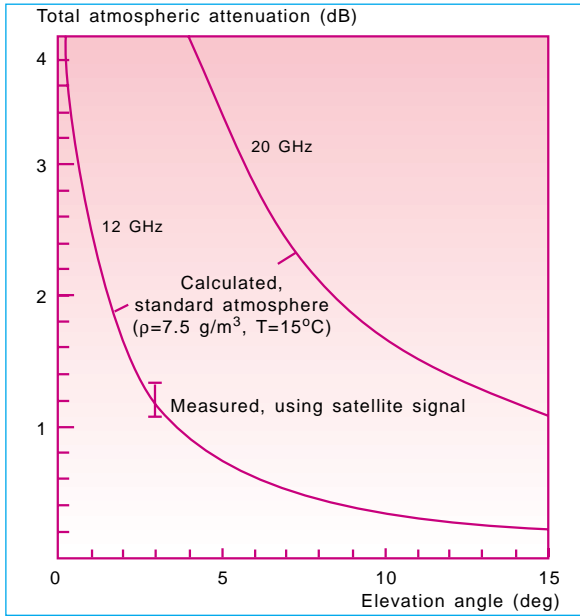


Figure 3 Total atmospheric attenuation as a function of elevation angle for a standard atmosphere (15°C temperature, 7.5 g/m<sup>3</sup> water vapour density). Measured value at 3° elevation angle is indicated

The total attenuation can then be calculated;

$$A = \gamma_o \cdot L_{eo} + \gamma_w \cdot L_{ew} \text{ (dB)} \quad (2)$$

where the equivalent path length is found from geometric considerations, figure 2:

$$L_e = \frac{2h}{\sqrt{\sin^2 \theta + \frac{2h}{R_{eff}} + \sin \theta}} \quad (3)$$

Using this approach, the atmospheric attenuation for 12 and 20 GHz has been calculated as a function of elevation angle, figure 3. A standard atmosphere is assumed, i.e. ground temperature of 15°C and water vapour density of 7.5 g/m<sup>3</sup>.

As can be seen, the attenuation for 12 and 20 GHz are less than 1 dB for elevation angles down to about 3° and 15°, respectively. At very low elevation angles, the atmospheric absorption will become a critical design factor.

From C/N-measurements of 12 GHz satellite signals at Spitzbergen (78° N, 3° elevation angle), the atmospheric absorption has been estimated. The measurements were performed with two satellites (OTS and EUTELSAT-I, F-2), and two receiving antennas (3 m and 7.6 m in diameter). At elevation angles less than 5°, defocusing loss and the decrease in antenna gain due to wave front incoherence will be of importance. For the actual antenna sizes and elevation angle, these effects are estimated to 0.7 - 0.9 dB [4]. Taking this into account, the satellite signal measurements showed an atmospheric absorption of 1.1 - 1.3 dB at 3° elevation, figure 3.

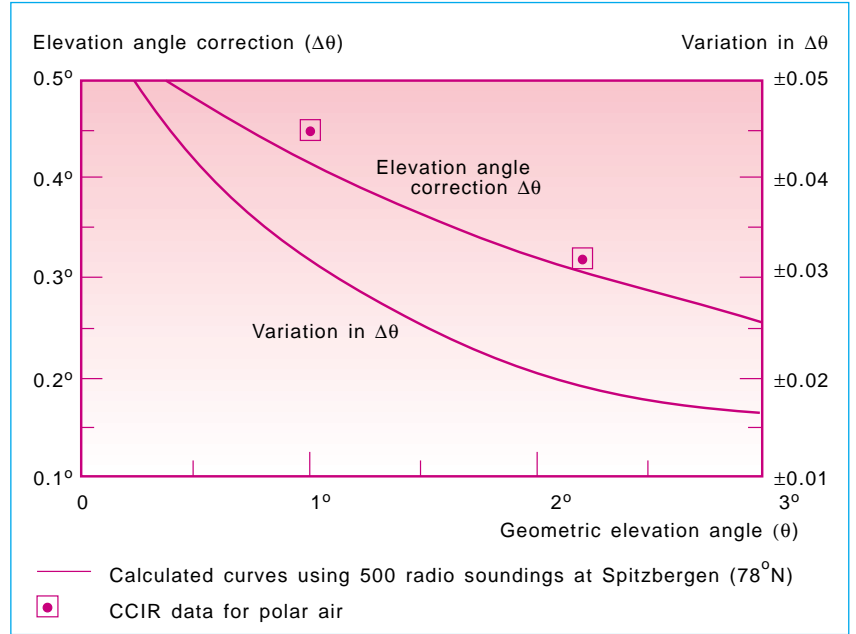


Figure 4 Average ray bending in polar areas

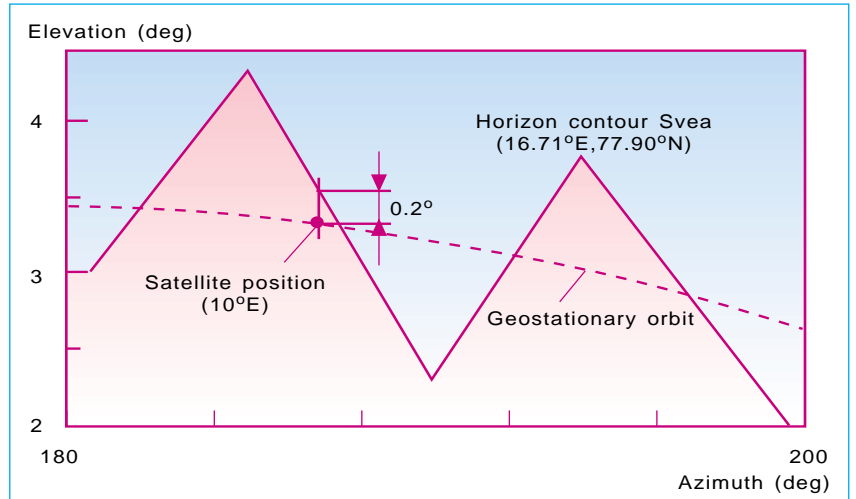


Figure 5 Horizon contour and geostationary orbit for Svea, Spitzbergen (16,71° E, 77,90° N)

This is quite close to the calculated value, which indicates that the model used for predicting the atmospheric absorption is reasonably good.

#### 4 Angle of arrival

The decrease of refractive index with height, causes bending of radio waves. This means that the apparent elevation angle to a satellite will be greater than the geometric elevation angle. At very low elevation angles, the correction will be of the same order of magnitude as the elevation angle.

From 500 radio soundings at Spitzbergen (1960), the refraction profiles

have been found [5]. The ray bending has been calculated, using the method described in ref. [6]. The results are shown in figure 4, together with data from CCIR [4].

As can be seen, there is good correlation between the calculated angle deviations and the CCIR data.

The normal refraction effect has been successfully utilised when receiving the satellite transmissions from EUTELSAT-1 (10° E) in Svea at Spitzbergen (77.9° N). Figure 5 shows the local horizon contour, and the geostationary orbit. The satellite is approximately 0.2° below the local horizon.



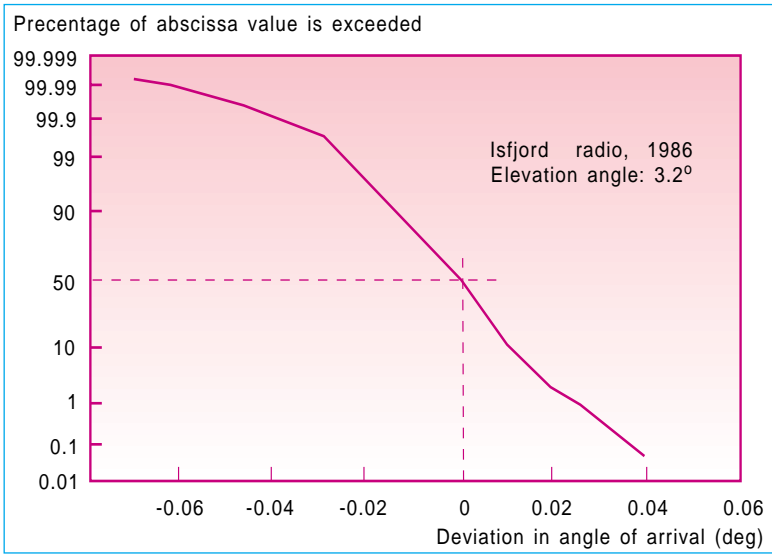


Figure 6 Cumulative distribution of angle of arrival measured at Isfjord Radio, 1986. Elevation angle 3.2°, frequency 11.5 GHz, mean ground temperature 4° C

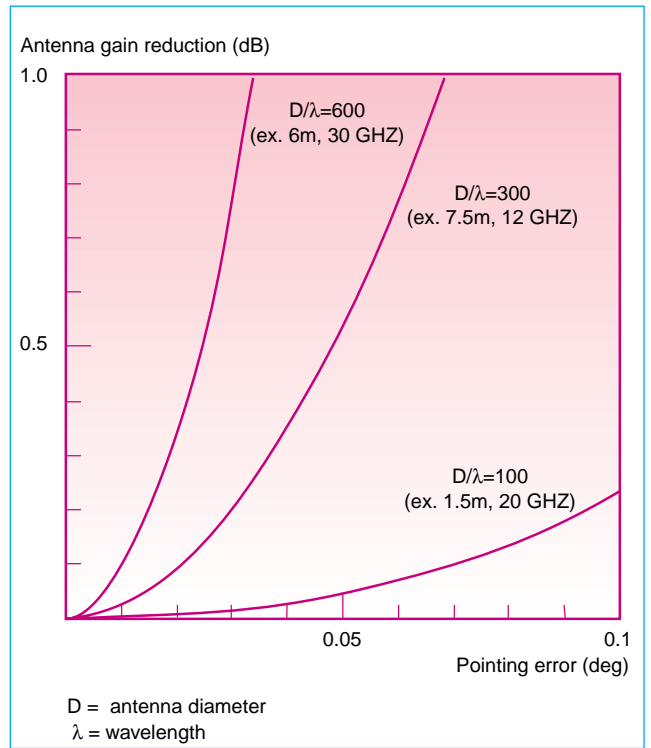


Figure 7 Reduction in antenna gain due to variation in angle of arrival

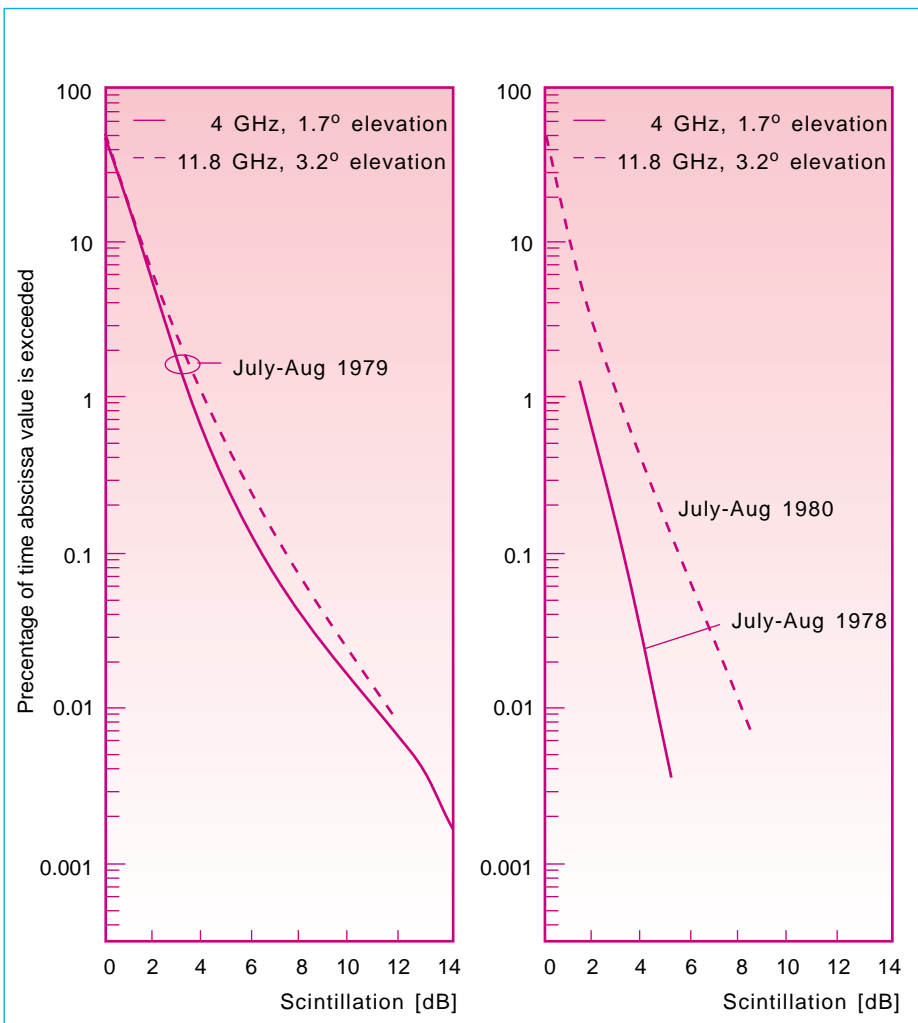


Figure 8 Measured scintillation distributions 4 and 11.8 GHz. Isfjord Radio, Spitzbergen, 1979

Figure 9 Measured scintillation distributions 4 and 11.8 GHz. Isfjord Radio, Spitzbergen, 1978 and 1980

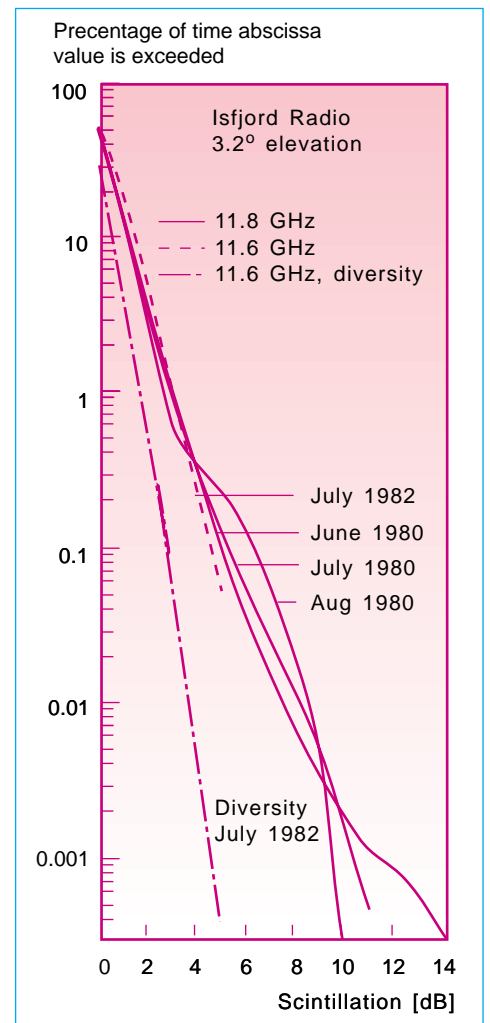


Figure 10 Measured scintillation distributions 11.8 GHz (1980 and 1982) and diversity (1982)

However, when taking into account the ray bending, the satellite will be seen above the local horizon.

Normally, the refractive index decays exponentially with height. Atmospheric turbulence will, however, cause random fluctuations about the average value of the refractive index. This results in random fluctuations in the apparent elevation angle to the satellite. This effect is important for earth stations operating at very low elevation angle without antenna tracking system.

Measurements of fluctuations in angle of arrival have been performed at Spitzbergen during summer 1986 [7] using the telemetry beacon of EUTEL-SAT-I, F-1 (13° E).

To obtain better accuracy, two 3-metres antennas were used, one pointing slightly above and the other below the nominal direction to the satellite.

The cumulative distribution of fluctuations in elevation angle is shown in figure 6. As can be seen, the deviations in angle of arrival is less than  $\pm 0.02^\circ$  in 95 % of the time. The distribution is approximately Gaussian. The slow variation due to satellite movement was filtered out.

Figure 7 shows the reduction in antenna gain as a function of the pointing error. A fluctuation in the angle of arrival of  $0.02^\circ$  reduces the gain 0.8 dB for a 6 metre antenna at 30 GHz or 0.2 dB for a 7.5 metre antenna at 12 GHz.

## 5 Tropospheric scintillations

Amplitude scintillations are generated by refractive index fluctuations in the lower part of the troposphere (<1 km). The fluctuations are caused by high humidity gradients, and temperature inversion layers.

For very low elevation paths to high latitude regions with scarce amount of rain, e.g. polar areas, tropospheric amplitude scintillations are the dominating propagation effect.

Long term measurements of this effect have been performed at Spitzbergen both at 4 GHz (1.7° and 3.1° elevation angle) [5], and 12 GHz (3.2° elevation angle) [8, 9]. Examples of measured cumulative distributions are given in figures 8, 9 and 10.

The turbulence activity is increasing with rising temperature in the atmosphere. One should therefore, to a certain extent, expect a dependence between scintillations and the ground temperature. It has been shown that such a relationship exists [11].

From statistical measurements at Spitzbergen ( $\varepsilon = 3.2^\circ$ ,  $f = 11.8$  GHz), the following equation has been established:

$$A_{sci} = 0.27 \cdot T_g + 6 \text{ (dB)} \quad (4)$$

where

$A_{sci}$  = fading level for 99.99 % of a month

$T_g$  = monthly mean ground temperature

Due to turbulence activity, the received signal will consist of a direct signal plus a scattered signal. If we assume that the scattered field consists of several components with random amplitude and phase, then the resulting signal distribution could be described by a Rice-distribution, i.e. a constant vector plus a Raleigh distributed vector.

In the measurements made at Spitzbergen, the scintillations were found to follow Rice-distributions with different values of the power ratio (K) of the random components to the steady component as given in table 1 [9].

According to the theory for turbulent scatter, the standard deviation of the scintillation amplitude is given by [4]:

	Worst day	Worst summer month	Average winter month
K	- 10 dB	- 13 dB	- 20 dB

Table 1

Measuring period	July/Aug 1979		July/Aug 1978 1980	
	Frequency (GHz)	11.8	4	4
Elevation angle (°)	3.2	1.7	3.1	3.2
Antenna diameter (m)	3.0	4.5	4.5	3.0
G(R)	0.923	0.954	0.940	0.923

Table 2

Frequencies	11.8 / 4	11.8 / 4*
Elevations	3.2 / 1.7	3.2 / 3.1
Theoretical scaling factor	0.97	0.55
Average measured scaling factor	1.11	0.59

Table 3

\*There are no simultaneous measurements of 4 and 11.8 GHz at 3° elevation angle. Since the average temperature for July/August 1978 and 1980 are approximately the same, the cumulative scintillation distribution for these periods are compared.

$$\sigma(f, \theta, D) \sim (f)^{\frac{7}{12}} \cdot \left[ \frac{1}{\sin \theta} \right]^{\frac{11}{12}} \cdot [G(R)]^{\frac{1}{2}} \quad (5)$$

where  
 $f$  = frequency (GHz)  
 $\theta$  = elevation angle (degrees)  
 $G(R)$  = antenna aperture averaging factor [4].

For the experiments at Spitzbergen, we have the technical data as shown in table 2.

The cumulative distributions of scintillations for the different measuring periods are shown in figure 8 and 9. Knowing one distribution, equation (5) can be used to scale this distribution to other frequencies and elevation angles.

A comparison of the theoretical scaling factors, calculated from equation (5), and the average scaling factors obtained from the measured distributions in figure 8 and 9, are given in table 3.

The measured values are in accordance with the calculated values. This means that the turbulence theory can be used with good accuracy for scaling a measured scintillation distribution to other elevation angles or frequencies.

To reduce the fading margin required for satellite links operating at very low elevation angle, space diversity may be employed. Site diversity measurements have been performed at Spitzbergen with a lateral separation of 1150 metres [9]. The single site and joint distributions are shown in figure 10. As can be seen, a substantial improvement is achieved. At a 3.2 dB fading level, the availability improves from 99 % to 99.9 %, due to site diversity. The diversity gain is 2 dB at 0.1 % of time. For smaller percentage of time, even larger diversity gain is expected.

## 6 Rain attenuation

Rainfall plays a major role in satellite communication, especially for systems operating above 10 GHz. A radio wave propagating through rain will be attenuated due to absorption, and scattering of energy by the water drops. The attenuation in dB per km ( $\gamma$ ) is related to the rainfall rate ( $R$ ) in mm/h. For practical applications this relationship can be written;

$$\gamma = a \cdot R^b \text{ (dB/km)} \quad (6)$$

where  $a$  and  $b$  are parameters depending on frequency and temperature [1]. Some values for  $a$  and  $b$  are given in table 4.

Since the rain intensity will vary along the path, the attenuation  $A(t)$  is obtained by integrating the specific attenuation  $\gamma$  over the total path length  $l$ :

$$A(t) = \int_0^l \gamma dx \quad (7)$$

where

$$\gamma = f[R(x, t)]$$

Knowledge of the rainfall rate distribution in one point is generally not enough for calculating the attenuation distribution. To be able to predict the rain attenuation, we introduce the concept of "equivalent path length", which is defined by;

$$A \text{ (dB)} = \gamma \cdot l_{eq}$$

or

$$l_{eq} = \frac{A(p)}{\gamma(R(p))} \quad (8)$$

where  $A(p)$  and  $R(p)$  are the attenuation and rain rate exceeded for  $p$  percentage of time (equal-probability values).

The equivalent path length is found from simultaneous statistical measurements of rain attenuation and rainfall rate. This has been done at 12 GHz both at Kjeller [10], and Kirkenes [11], with elevation angles 22° and 10°, respectively. The measured equivalent path lengths are presented in figure 11. Linear interpolation has been used for calculating the equivalent path lengths for intermediate values of the elevation angle.

When knowing the cumulative distribution of rainfall rate in one point, we are able to calculate the attenuation distribution by using equation (6) and figure 11. In Norway, rain intensity data from tipping-bucket gauges are available in more than 50 places and for several years. This information has been used to identify regions of different rainfall rate statistics, see figure 12.

The described prediction model has been used to calculate the 12 GHz rain attenuation distribution for;

- Zone A, elevation angle 11.5° (Tromsø)
- Zone A, elevation angle 18° (Trondheim)

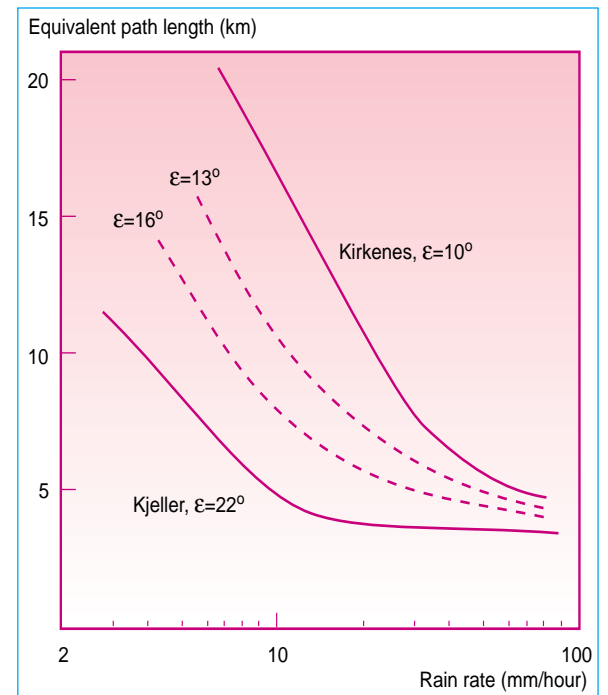
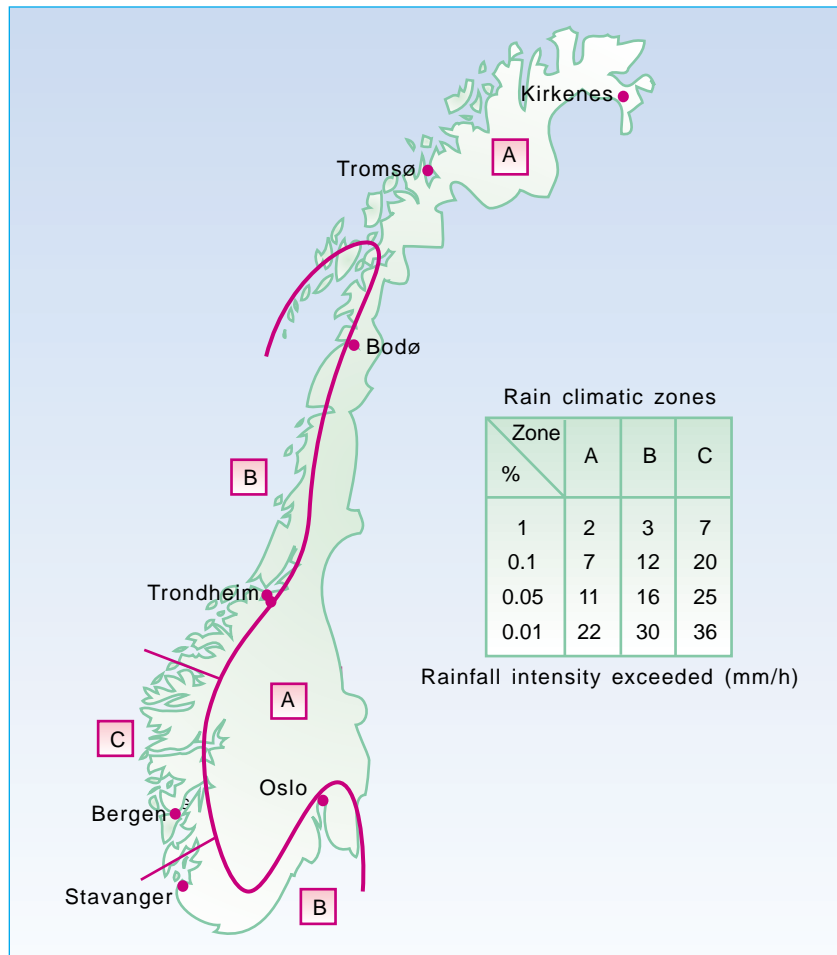


Figure 11 Equivalent path length through rain

Frequency (GHz)	Horizontal pol		Vertical pol	
	a	b	a	b
12	0.0188	1.217	0.0168	1.200
15	0.0367	1.154	0.0335	1.128
20	0.0751	1.099	0.0691	1.065
30	0.187	1.021	0.167	1.000

Table 4



- Zone C, elevation angle 21° (Bergen).

The predicted and measured distribution are compared in figure 13 and 14. As can be seen, the deviations are quite small, and within what is expected due to year-to-year variations of the rainfall rate.

As the equivalent path length is independent of frequency, attenuation distributions for other frequencies can be predicted. Figure 15 shows the calculated cumulative rain attenuation distribution for 20 GHz in Zone A, elevation angle 20°. The predicted attenuation is compared with attenuation results from the Helsinki 20 GHz radiometer [12]. Helsinki has approximately the same rain intensity climate as zone A. There is a reasonable agreement between the distributions.

The good correlation obtained between the calculated and measured rain attenuation distributions should demonstrate the usefulness of the described prediction procedure.

Figure 12 Rain climatic zones for Norway

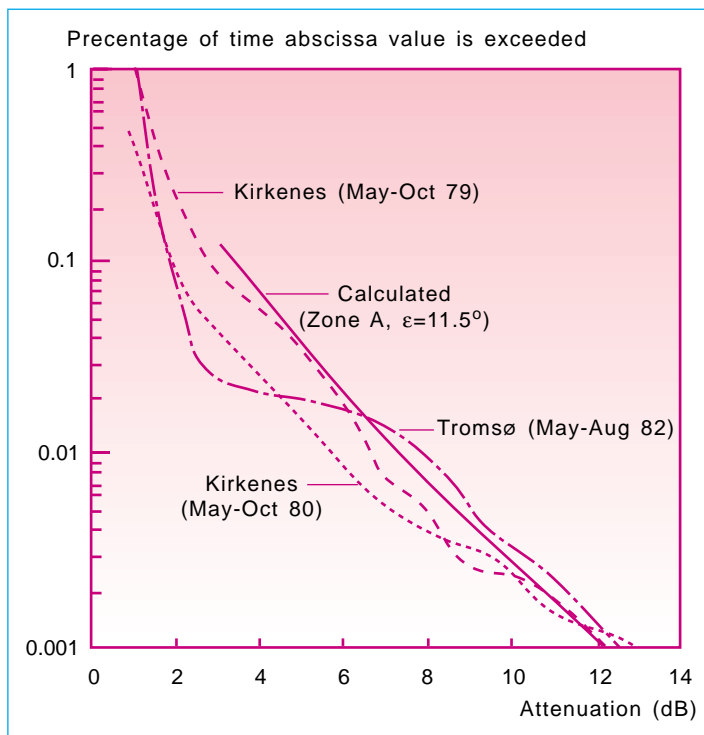


Figure 13 Cumulative distributions of rain attenuation measured in Kirkenes ( $\epsilon = 10.5^\circ$ ) and Tromsø ( $\epsilon = 11.5^\circ$ ). Calculated distribution for zone A ( $\epsilon = 11.5^\circ$ )

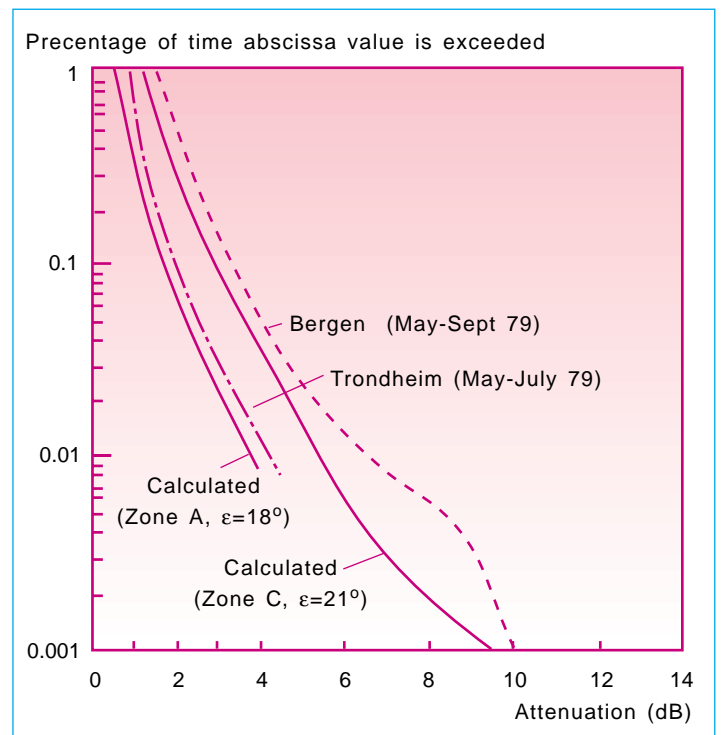


Figure 14 Cumulative distributions of rain attenuation measured in Trondheim ( $\epsilon = 18^\circ$ ) and Bergen ( $\epsilon = 21^\circ$ ). Calculated distributions for zone A ( $\epsilon = 18^\circ$ ) and zone C ( $\epsilon = 21^\circ$ )

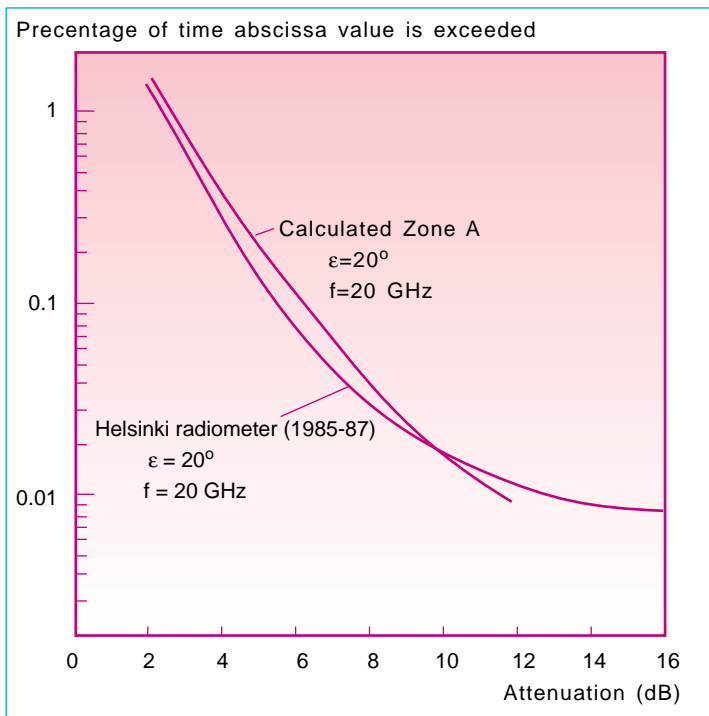


Figure 15 Cumulative distribution of 20 GHz attenuation measured with radiometer in Helsinki (zone A,  $\epsilon = 20^\circ$ ). Calculated distribution for zone A ( $\epsilon = 20^\circ$ ) including 0.8 dB gaseous absorption

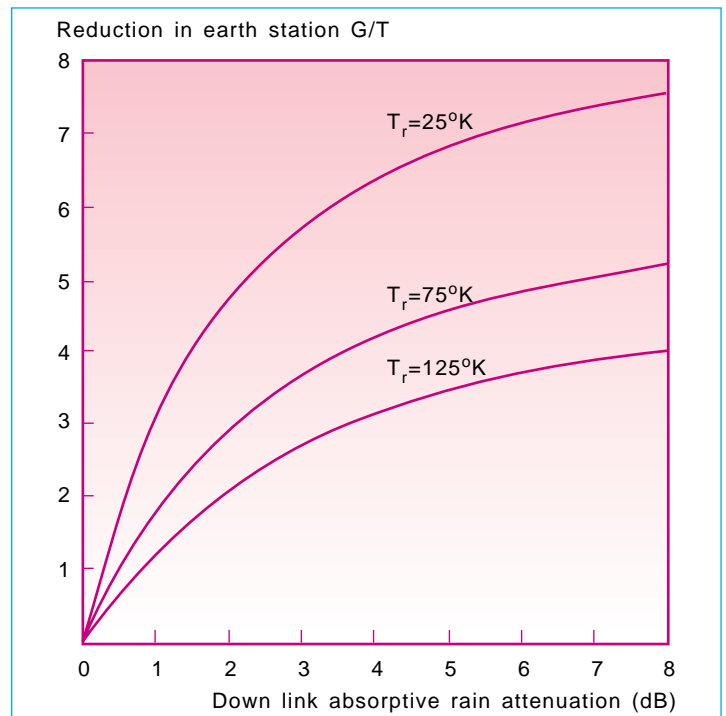


Figure 16 Reduction in earth station  $G/T$  as a function of the down link attenuation.  $T_r$  = receiver noise temperature. Clear sky noise temperature of antenna  $T_{ao} = 25^\circ K$

## 7 Noise Temperature

Any absorbing medium, such as atmospheric gases and rain, will in addition to attenuating a radio signal produce thermal noise power radiation. This noise emission is directly related to the intensity of absorption. If we consider the atmosphere as an absorbing medium with an effective temperature of  $T_m$  and a loss factor of  $L$ , the contribution to the earth station antenna noise temperature  $T_a$  is given by;

$$T_a = (1 - 1/L) T_m \quad (9)$$

$T_m$  varies between 260 - 280° K depending on the atmospheric conditions.

An increase in antenna noise temperature will give a corresponding decrease in the earth station figure of merit ( $G/T$ ). As the clear sky system noise temperature decreases due to better performance of low noise front-ends and antennas, the decrease in  $G/T$  could be larger than the attenuation itself.

An example of the degradation in  $G/T$  as a function of down-link absorptive rain attenuation is given in figure 16.

The following values are assumed:

- Gaseous absorption: 0.2 dB
- Antenna ground interception factor: 3.5 % (NORSAT-B antennas)
- Effective absorbing medium temperature: 280° K.

This corresponds to a clear sky antenna noise temperature of 25° K.

The degradation of the down-link carrier to thermal noise ratio (dB) will be the sum of the reduction in  $G/T$  (dB), and the down-link attenuation (dB).

## 8 Cross polarisation

To increase the channel capacity, orthogonal polarisations can be employed. However, due to atmospheric effects, there will be a transfer of energy from one polarisation to another. This will cause interference in dual polarised satellite links. Depolarisations are mainly caused by rain and snow along the path.

Cross polarisation discrimination ( $XPD$ ) has been measured at Kjeller and Spitzbergen. Figure 17 shows equi-probability plots of the  $XPD$ , and the copolar attenuation [8-10]. The depolarisations measured at Kjeller are caused by rainfall, whereas the depolarisations measured at Isfjord and Spitzbergen, are believed to be due to sleet, snow and/or atmospheric turbulence.

Due to the short measuring period at Kjeller (two summer months), there is a discrepancy between the predicted  $XPD$  (CCIR), which is based on long-term statistics, and the measured  $XPD$ .

Snow and atmospheric turbulence appear to be a less polarising medium than rain.

## 9 Snowfall Attenuation

Dry snow has little effect on frequencies below 30 GHz. Sleet or wet snow can, however, cause larger attenuation than the equivalent rainfall rate [10].

Along the North Atlantic coast of Norway, the intensity of wet snowfall is known to be high. Measurements at 12 GHz in Tromsø (70° N) showed that the "winter attenuation" was much larger than "summer attenuation" for the year 1982. Attenuation up to 15 dB due to sleet were experienced [11].

## 10 Conclusions

Prediction models for gaseous absorption, tropospheric scintillations and rainfall attenuation have been established. The described methods have successfully been used when designing commercial 11/14 GHz satellite systems in Norway, including Spitzbergen.

To a certain extent, these models can be utilised for planning of satellite systems in the 20/30 GHz band. Through the Norwegian participation in the propagation experiments with the OLYMPUS satellite, more reliable data of the atmospheric influence on satellite links will be established.

As the attenuation increases, different techniques have to be used in order to keep the fading margins to a minimum. These techniques include site diversity, power control, spot beams in the satellite and possibly adaptive allocation of system capacity.

## 11 References

- 1 Ippolito, L J. *Radio wave Propagation in Satellite Communications*, Van Nostrand Reinhold Co. Inc, New York, 1986.
- 2 Davies, P G, Norbury, J R. Review of slant path propagation mechanism and their relevance to system performance, *IEE Proceedings*, Vol 130, Part F, No 7, Dec 1983.
- 3 Davies, P G, Norbury, J R. Review of propagation characteristics and prediction for satellite links at frequencies of 10-40 GHz, *IEE Proceedings*, Vol 133, Part F, No 4, July 1986.
- 4 CCIR Recommendations and reports, Vol V. *Propagation in non-ionized media*, ITU, Geneva 1986.
- 5 Osen, O. *Propagation Effects in High Latitudes*, Symphonie Symposium, Berlin, 1980.
- 6 Schulkin, M: Average Radio-Ray Refraction in the Lower Atmosphere, *Proceedings IRE*, May 1952, 554-561.
- 7 Erring, B. *Variasjoner i innfallsvinkel for satellitkommunikasjon ved lave elevasjonsvinkler*, Hovedoppgave, NTH, Trondheim 1987.
- 8 Gutteberg, O. Measurements of tropospheric fading and crosspolarization in the Arctic using Orbital Test Satellite, *IEE Conference Publication 1*, No 195, Part 2, 71-75, IEE 2nd International Conference on Antennas and Propagation, York 1981.
- 9 Gutteberg, O. Measurements of atmospheric effects on satellite links at very low elevation angle, *AGARD Conference Proceedings*, No 346, 5-1 to 5-12, 1983.
- 10 Gutteberg, O. Eksperimenter med OTS-satellitten, *Teletronikk 4/1981*.
- 11 Gutteberg, O. *Low elevation propagation in high latitude regions*, TF report No 7/83, Norwegian Telecom Research, 1983.
- 12 Kokkila T. *Private communications*

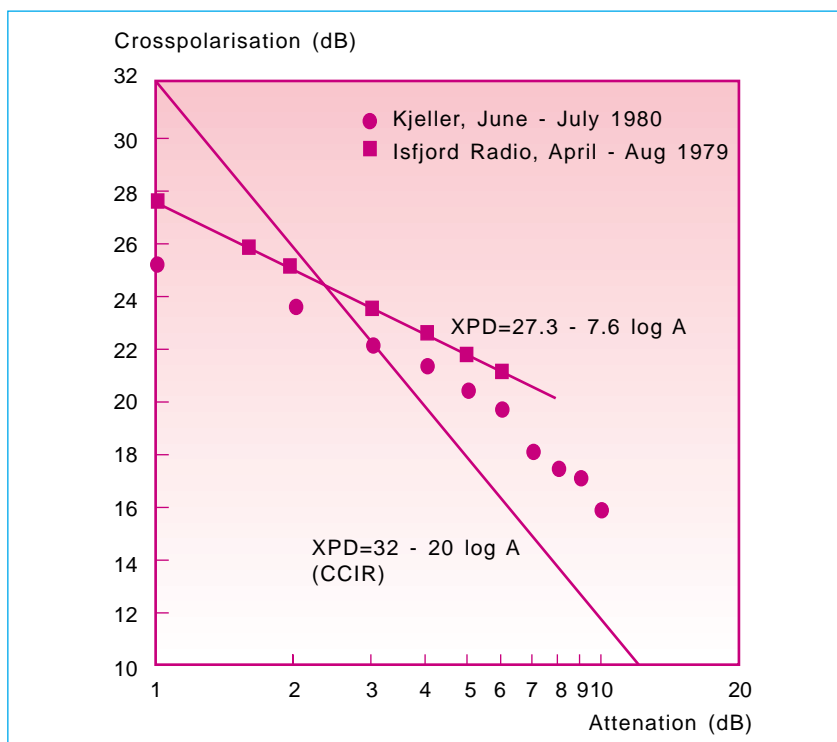


Figure 17 Crosspolarisation discrimination (XPD) as a function of co-polar attenuation (A)

# The use of millimetre waves in satellite communications

BY TORD FREDRIKSEN

## Introduction

This paper presents the most important issues concerning the use of millimetre waves in satellite communications. Present satellite communication uses microwave frequencies in the C and Ku bands, that is the frequencies 4/6 GHz and 11/14 GHz. The reason for using these frequencies is that they are not reflected in the atmosphere like lower frequencies as VHF. 4/6 GHz was the first band to be used and as it has limited capacity, systems operating at 11/14 GHz were deployed. If the volume of satellite carried traffic continues to increase over the next years (as is likely), we may find ourselves in the situation where all these bands are completely filled.

This is the reason why higher frequencies are considered. Millimetre waves have wavelengths shorter than one centimetre, thus the frequency is over 30 GHz. The bands of interest are 20/30 GHz (even though the frequency is too low in a strict sense) and up to approximately 60 GHz (higher frequencies are not of practical interest yet). Experiments are currently carried out at 20/30 and 40/50 GHz in Europe to study the behaviour of millimetre waves in earth-space communication.

The frequencies up to ca 300 GHz have been assigned to different services by ITU (International Telecommunications Union, a body in the United Nations system), and whereas the C and Ku band offer bandwidths of 1 GHz each, the bands at 20/30 and upwards offer several GHz each. This means that bandwidth limitation does not have to be a critical design factor.

First part of this article will discuss the use of millimetre waves in terms of 1) the problem of absorption in the atmosphere, 2) the advantages of small wavelengths and 3) the technological challenges. Section 4 briefly describes ways of overcoming the obstacle of attenuation. Finally, in section 5, an outline of a proposed mobile satellite communication system based on millimetre waves is given. The proposal abandons the familiar idea of the geostationary satellite.

## 1 Propagation

The obvious basis of all radio communication is that electromagnetic waves propagate through the space between

transmitter and receiver. In satellite communications the medium along most of the path is close to free space, which is non-discriminative against any particular frequency and therefore very easy to describe. Matters are more complicated along the part of the wave path that is in the earth's atmosphere, as we shall see.

Keeping matters simple we will in the following only deal with the most important propagation variable, namely attenuation.

As the electromagnetic wave (i.e. the signal) travels through the atmosphere, it is attenuated by gaseous absorption and absorption and scattering in water in different forms: clouds, fog, snow, hail, rain and ice. This constitutes a frequency discriminating and time varying channel in which the amount and distribution of water is the important variable. The exact effects of atmospheric disturbances are not completely known, but today, attenuation phenomena are modelled with some accuracy.

In designing an earth-space communication system, estimation of expected propagation conditions is of prime importance. Part of the specification of a communication system is the maximum allowed outage time, i.e. portion of time that the link is not functioning. Dependable propagation data are the key to give reliable figures on this outage time.

### 1.1 Absorption in gases

Gaseous absorption is mainly due to oxygen and water vapour. As shown in figure 1, attenuation generally increases with frequency and exhibits peaks at resonance frequencies of the O<sub>2</sub> and H<sub>2</sub>O molecules. Below 10 GHz, the specific attenuation is relatively constant. Above 10 GHz, one must avoid the peaks and thus use the "frequency windows" between 22.2, 60 and 118 GHz.

The O<sub>2</sub> absorption is relatively constant over time, depending only on air pressure variations. The H<sub>2</sub>O absorption, however, is time-varying in proportion with changes in water vapour density. This variation itself applies equally to all frequencies and is therefore no issue in this context. However, the attenuation levels are higher at higher frequencies. This is an important limiting phenomena in using millimetre waves.

Obviously, frequencies near the attenuation peaks should not be used in earth-space communications. However, frequencies in the absorption band around 60 GHz can be used in inter-satellite links. This would entirely eliminate any interference problems with terrestrial systems. A possible use is in links between earth sensing satellites and relay satellites for downloading data to the earth.

### 1.2 Attenuation by hydrometeors

Rain is the major attenuation phenomena and its effect increases with frequency.

Figure 2 shows attenuation increasing with frequency and with rain rate. (Typical rain rates for Norway are given in (1), fig 12.)

For a system to stay in service, i.e. maintain acceptable C/N at a given rain rate, it has to be designed with a link margin greater than the corresponding fade depth. One fade level distribution is given in (2), figure 3 for 11.6 GHz and 50 GHz (at Lario, Italy). Note the extreme fade levels at 50

621.396.946

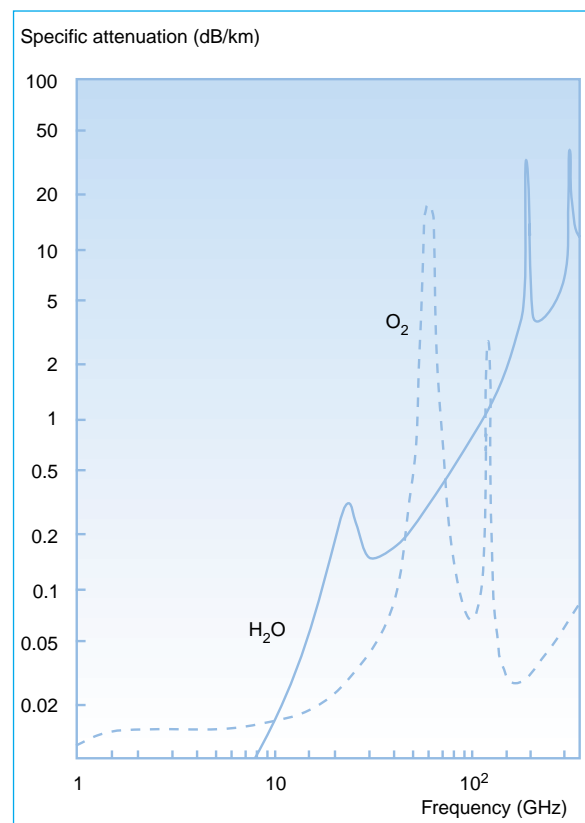


Figure 1 Specific attenuation due to atmospheric gases

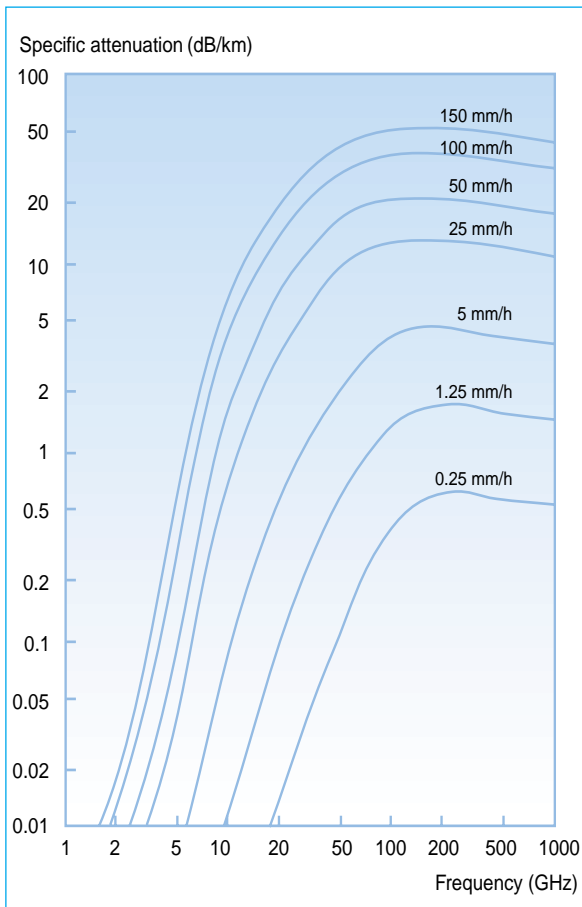


Figure 2 Specific attenuation due to rain

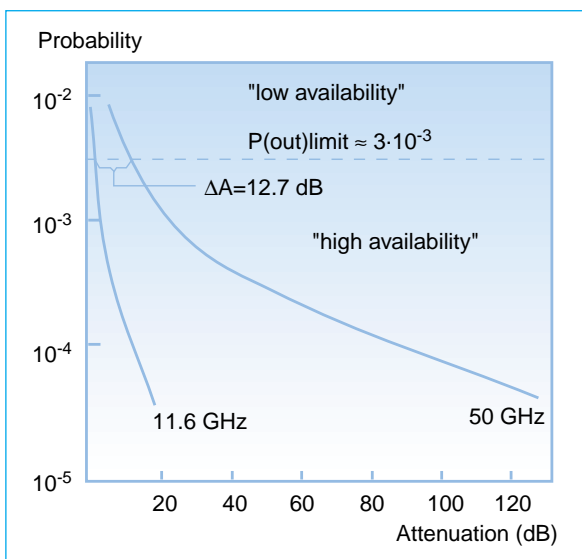


Figure 3 Cumulative attenuation statistics at 11.6 GHz and 50 GHz, Lario, Italy. Note the extreme attenuation values at 50 GHz

GHz, reaching 100 dB for a small fraction ( $10^4$ ) of time.

For instance, to have an availability greater than 99.9 % at this site (outage time less than 0.1 % or 9 hours in one year), one needs a minimum margin of 3 dB for an 11.6 GHz link and minimum 22 dB for a 50 GHz link. The latter is clearly not feasible due to unacceptable increase in required EIRP and/or receiver G/T (figure of merit). As apparent from figure 3, (2), the required excess margin (horizontal distance between the two curves) increases dramatically with increased availability demands.

This somewhat frightening characteristic of using higher frequencies can be dealt with in two ways:

- 1 Accepting higher outage rates
- 2 Applying methods such as site diversity, frequency diversity, adaptive coding or adaptive power control at the cost of station complexity and mobility.

We will come back to this in sections 4 and 5.

## 2 The principal advantage of high frequency: "frequency gain"

High frequency allows narrow beams, i.e. concentrating the power in small areas. Given a transmitter-receiver radio system, Friis equation of received power (in free space) is

$$P_r = P_t A_t A_r \left( \frac{1}{\lambda R} \right)^2$$

saying that decreased wavelength increases received power, other parameters held constant.  $P_r$  and  $P_t$  are received and transmitted power,  $A_r$  and  $A_t$  are the effective antenna areas,  $\lambda$  is wavelength and  $R$  is the distance. Comparing the received power at two different frequencies, other parameters held constant:

$$\frac{P_{r1}}{P_{r2}} = \frac{\left( \frac{1}{\lambda_1} \right)^2}{\left( \frac{1}{\lambda_2} \right)^2} = \left( \frac{f_1}{f_2} \right)^2$$

This can be viewed as a gain

$$20 \log \frac{f_2}{f_1} \text{ (dB)}$$

obtained by changing the frequency from  $f_1$  to  $f_2$ . (It is of course closely related to antenna gain and path loss.) Realising this gain can be done by

- i) reducing antenna area while maintaining EIRP
- ii) reducing power consumption while maintaining EIRP
- iii) increasing EIRP and thus improving the fade margin.

i) and ii) give the advantages of smaller and less power consuming earth stations and satellites, thereby reducing launch cost or facilitating more complex satellites. Earth stations can become mobile. ii) generally implies narrower beams, thereby facilitating frequency reuse.

As we have seen in section 1, this does not come without a penalty in the form of more and deeper fade time. The penalty balances the advantage at some fade intensity probability. Referring to figure 3, we have a frequency increase advantage of

$$G_f = 20 \log(50/11.7) = 12.7 \text{ dB}$$

The point at which the horizontal distance between the 50 and 11.7 GHz curves equals this value is at approximately  $P(\text{out}) = 3 \cdot 10^{-3}$ . If we accept outage probabilities higher than this we have a net gain/advantage in increasing the frequency. Conversely, if we demand lower outage probabilities we have to compensate by increased link margin or shared resource techniques. This balance point divides two sets of systems:

- low availability systems
- high availability systems.

High availability systems will generally be integrated in the terrestrial communications network and therefore under strict requirements regarding quality of service. Such systems are also known as network oriented systems. Low availability systems will not serve as an integral part of the terrestrial system, they will therefore be inherently user oriented. It is likely that users will own and operate their own earth stations. Interfacing with the earth net might well be possible anyway.



### 3 Technology

The use of millimetre wave components requires elaborate HW development. Such components are not in large scale commercial use (at present). This means that most parts have to be custom built.

An inherent property of all common transistor technologies is that noise factor rises and gain falls with increased frequency. This has a negative impact on receiver G/T. Silicon transistors are for instance not applicable at millimetre wave frequencies. GaAs transistors are better. In particular, AlGaAs HEMTs (High Electron Mobility Transistors) have been produced with very promising characteristics. Figures like NF = 0.8 dB and gain = 8.7 dB at 63 GHz have been reported. At present, different experiments are conducted (in the US and Japan) to obtain high quality devices at high frequencies.

Thus this technology is somewhat immature, and one cannot expect large-scale production with high yield in the near future. Large-scale production of completely integrated millimetre wave circuits (wave guides, filters, mixers, amplifiers on one substrate) is necessary to produce cheap user terminals.

Another challenge is increased accuracy on all dimensions. Acceptable dimension error is a function of wavelength, and as this is lowered, accuracy/precision must be increased. This applies in particular to antenna production.

A third problem is the DC-to-RF power conversion. This is generally more efficient at low frequencies. Other losses (e.g. in mixers) also increase with frequency. One can compensate for this by having larger solar arrays, but this is of course not an attractive solution because of higher launch mass.

So, it must be clear that realising the possible merits of millimetre wave systems is not straightforward. One might risk that higher losses and lower component efficiency cancels out the nice features and that one is left with a net disadvantage in applying higher frequencies. Keeping this in mind and putting effort into solving these problems, one should be able to construct systems with lower power consumption than today's have.

### 4 Fade combatting techniques

This section discusses methods to counteract the deep fades likely at high frequencies. The goal is to maintain high availability despite the fades. These techniques are most likely to be used in network oriented systems. The following presents four such techniques.

*Site diversity* is a technique where two or more earth stations are used to receive the signal. The distance between the stations can be for instance 15 km. This technique requires as a minimum a set of duplicate stations with an earth connection between them and equipment for co-ordination of the stations. The simplest implementation is just choosing the strongest signal. More sophisticated signal processing techniques make use of the correlation of the signals to increase the legibility. In the limiting case of statistically independent stations, the probability of simultaneous outage is  $P_{\text{sys}} = P_1 \cdot P_2$ ,  $P_1$  and  $P_2$  being the probabilities of outage at stations 1 and 2, respectively. This is a major improvement, consider for instance that  $P_{\text{sys}} = 0.01\%$  required means  $P_{\text{sys}} = 0.0001 = > P_1 = P_2 = 0.01 = 1\%$ . However, statistical independence is a strong assumption and is seldom justified. Depending on the geographical separation, the assumption might hold in the case of high intensity rain, i.e. deep fades, because this normally occurs in showers of limited geographical extension. In the case of low intensity rain it is not likely to hold because this type of rain normally covers a large region. These dependencies have to be studied further to achieve data for system design.

Another technique is *frequency diversity*, where a complete backup transmitter and receiver exist at a lower frequency. This presupposes a large number of stations so that the capacity of the backup system is small compared to the overall capacity. (Or else it would be better only to use the backup.) Again, statistically independent stations with large spacing is desirable. Satellite complexity will increase due to the need for steerable antennas (for the backup) and due to the inclusion of a fade monitoring and capacity assignment system as well as the backup system itself.

A third technique is *power control*, in which emitted power from the satellite is adjusted according to propagation conditions. A sensible way of using this would be in a satellite serving a large region (Europe) by many narrow beams. The output power margin could be continuously assigned to the worst-off beams. The excess power that can be made available in the satellite is of course limited, say to 10 dB in one beam. Consequently, this is probably not a good method at high frequencies (see again figures 2 and 3), but maybe it is feasible at 20/30 GHz. Again, considerable overhead has to be added in terms of link monitoring and shared resource administration.

*Adaptive coding* is another shared resource technique. The backup resource is time or frequency which is allotted to the bad-off earth station in the form of extended time frames in time division systems or extra bandwidth in frequency division systems. The extra capacity is put to use by increased redundancy (excessive) coding. Implementation in FDMA systems would be difficult because of required shifts of carrier frequencies, whereas TDMA systems would require simple time slot shifts.

Except for site diversity, the four techniques discussed here all utilise some system-common resource to relieve the areas experiencing unpleasant millimetre wave propagation conditions. As such they are based on systems consisting of many large stations. They add considerable complexity to the system. The possible benefits must be subject to further study to quantify improvement or gain. If these techniques can be applied successfully, it will be possible to design the (normally operating) millimetre wave part of the system as a low-availability system, i.e. with outage times in the order of 1 %.

### 5 A low availability system for mobile communications

This section will briefly describe a millimetre wave satellite system for mobile communications proposed by Valdoni et al. (3). This is an example of a low-availability system that exploits the nice features of high frequency at the cost of worsened propagation conditions.

Operating at 40/45 GHz it will offer full duplex 64 kbit/s (ISDN 2B+D) with bit error rate  $10^{-6}$  and 99 % availability. Earth station antennas will be phased arrays of approximate size 22 x 22 cm (Rx) and 6 x 6 cm (Tx), i.e. suitable for integration in cars. The idea is to supplement terrestrial cellular systems by offering 1) good coverage in suburban and rural areas and 2) higher bit rates. The main advantage of a satellite mobile system over a terrestrial one is that once launched, it serves the complete planned coverage area, including scarcely populated areas. The terrestrial system, on the other hand, is built up gradually, one cell at a time, and it is not economical to deploy stations in many rural areas.

A good space segment would consist of three satellites in highly inclined orbits. Because millimetre waves are seriously impeded/stopped by obstacles in the path, the elevation angle should be as high as possible, in order to reduce the probability of obstacles in the path. Also, high antenna gain eliminates multipath propagation and thus the receiver depends only on the direct path. Ideally then, the satellite should be in zenith. A highly inclined elliptical orbit like the Molniya orbit (4), figures 7 and 8) gives a quasi stationary satellite near the apogee for 8 hours per revolution of 12 hours. Using three satellites properly phased in three orbits give continuous coverage from near zenith elevations (>60 deg.) all over Europe. I repeat here the orbital parameters:

T	= 12 hours
inclination	= 63.4 degrees
$H_{\max}/H_{\min}$	= 39,100/1,250 km
H handover	= 23,500 km
visibility	= 8 hours.

This will give very high elevation angles, reducing the blocking problems significantly. Besides, attenuation in rain and gases, which is proportional to the path length through the atmosphere, is also reduced when elevation increases.

But this orbital constellation entails new difficulties compared to geostationary systems. First, there is the zooming effects: As the distance to the satellite changes, cell size (coverage area per beam) changes with a factor of 1.7 from handover to apogee. This might necessitate dynamic beam shaping in the satellite, which is possible

by electronically steerable antennas. Second, Doppler shift can be in the order of several hundred kHz. This is mainly caused by satellite, not earth station, movement and has to be compensated in the satellite or earth station. All this means that both the satellite and the earth stations increase in complexity. This has also been the case with terrestrial cellular systems. Today's mobile stations and base stations have very advanced network access procedures and signal processing. In moving to mobile satellite systems, one must expect the complication level to increase further with functions like electronic antenna tracking, dynamic beam shaping, new handover procedures, dynamic "bandwidth" allocation and frequency shift compensation.

## Conclusion

The shift upwards in frequency is necessitated by the congestion of bands in present use. But, into the bargain, millimetre waves have the merit of narrow beams and/or small antennas. On the other hand, they experience difficult propagation conditions and the component technology is in its adolescence. This may favour systems completely different from today's, for instance mobile satellite systems in inclined low earth orbits or elliptical orbits. As with all technology changes, it is not just a simple case of "interpolating" on, or "adjusting", contemporary systems. We have to expect or even pave the way for completely new systems.

## References

- 1 Gutteberg, O. Effects of atmosphere on earth-space radio propagation, *Teletronikk*, 4/92, 63-70.
- 2 Carassa, F. Application of millimeter waves to satellite systems, *Alta Frequenza*, vol LVIII N.5-6, Sept-Dec 1989.
- 3 Valdoni, F et al. A new millimetre wave satellite system for land mobile communications, *European Transactions on Telecommunications and Related Technologies*, ETT vol I-N.5, Sept-Oct 1990.
- 4 Hovstad, P, Gutteberg, O. Future systems for mobile satellite communications, *Teletronikk*, 4/92, 54-62.

# The effect of interference for an OBP system utilising the geostationary orbit

BY PER HOVSTAD

621.396.946  
629.78

## Abstract

A method is described to calculate the required increase in earth station antenna diameter for a system based on high-gain satellite receive spots and low uplink EIRPs in an environment with interference from other satellite systems. The system is comparable to other systems on the downlink, and interference is therefore assumed to affect primarily the uplink. Correspondingly, calculations are performed only for the uplink.

It is shown that in an environment with interference, earth station design will be determined by the need to suppress this interference, by proper transponder planning and choice of position in the geostationary arc. However, it can be seen that the effects of interference can be greatly reduced.

## Required OBP earth station characteristics in an environment with interference

The ESA OBP (On-Board Processing) system is designed to allow direct communication between small, inexpensive earth stations in a mesh type network. In order to achieve this goal, ESA intends to use a payload with multiple high gain spot beams combined with a regenerative digital baseband switch. This last feature in order to obtain a large coverage area (Europe) in a flexible way.

Terminal data rates will be 64 kbit/s - 2 Mbit/s with access on a multi frequency TDMA system. 2 Mbit/s on the uplink, and 33 Mbit/s on the downlink.

Because of the high satellite G/T, and the low earth station EIRP, the system is believed to be sensitive to interference from other systems on the uplink. This paper describes a simplified method to determine the effect of interference upon the earth station design of an OBP system operating in the FSS Ku-band (up 14.0 - 14.5 GHz, down 12.5 - 12.75 GHz).

The procedure to determine the influence that interference will have on terminal design is as follows:

- 1) Specify the quality requirements for the system, given by the required C/N+I. Interference is assumed uncorrelated to wanted signal, but not necessarily with uniform spectral power distribution. It is assumed to affect the uplink much more than the downlink, since while the downlink has power flux densities comparable to that of other systems, the uplink is characterised by an unusually high gain satellite antenna and correspondingly low uplink EIRPs. Interference calculations are therefore performed only for the uplink. C/N + I is given from the equation:

$$\frac{1}{C/N+I} = \frac{1}{C/N} + \frac{1}{C/I} \quad (1)$$

Where  $I$  is the sum of all interfering sources:

$$I_i = \Sigma I_i \quad (2)$$

- 2) Establish the characteristics of the various interfering sources.
- 3) Establish the ground and space segment characteristics as well as wanted signal characteristics.
- 4) Determine C/N as a function of EIRP and G/T for uplink in the case with no interfering sources.
- 5) Required uplink EIRP and downlink G/T to meet the quality specifications are found for the interference free case. Assuming HPA power, receiver noise figure and antenna characteristics, this is converted to antenna diameter. Assuming that the same antenna is used in both directions, the largest diameter will apply.
- 6) The critical rain attenuation is found as the case where the quality requirements lead to the largest terminal antennas. This value is used in the following calculations.
- 7) Assumptions on interfering systems, their orbital position and spectral power distributions are made.
- 8) Uplink C/I as a function of assumed interference characteristics and terminal EIRP is calculated.
- 9) Up-link C/N + I is calculated from (1) as a function of terminal EIRP and satellite G/T.
- 10) Necessary uplink C/N + I from the quality requirements then determines terminal EIRP, and thus antenna diameter, when assuming HPA power and receiver noise figure unchanged.
- 11) Antenna diameter for various interference scenarios (orbital posi-

tions, choice of frequency) is compared to the interference free case, and gives a measure for the impact of interference.

## 1 OBP quality requirements

The quality requirements aimed to meet are those given in CCIR Rec. 614:

$$BER_{tot} \quad (3)$$

- >  $1 \cdot 10^{-7}$  for less than 10 % of any month
- >  $1 \cdot 10^{-6}$  for less than 2 % of any month
- >  $1 \cdot 10^{-3}$  for less than 0.2 % of any month

In link budget calculations, the up- and downlinks are independent of each other because of the regenerative nature of the payload. In [2], A10-12, it is shown that with a 0.3 dB link margin, each link can be designed independently to meet the quality requirements, still meeting the overall performance objectives.

With the modem and multi-carrier demodulator characteristics from [2], Table A10.2-1, CCIR Rec. 614 can be rewritten:

$$(E_b/N_0)_{up} \quad (4)$$

- < 14.0 dB for less than 10 % of any month
- < 13.2 dB for less than 2 % of any month
- < 9.0 dB for less than 0.2 % of any month

$$(E_b/N_0)_{down}$$

- < 13.8 dB for less than 10 % of any month
- < 12.9 dB for less than 2 % of any month
- < 8.1 dB for less than 0.2 % of any month

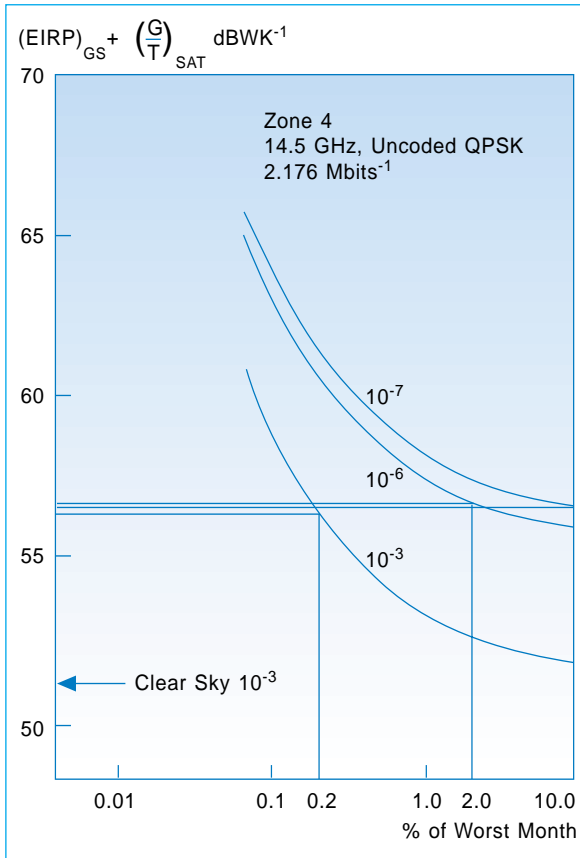


Figure 1 ([1] figure 3.3.6.1-3)  
Required uplink  $(EIRP)_{GS} + (G/T)_{SAT}$  to meet a specific BER for a given percentage of time (worst month)

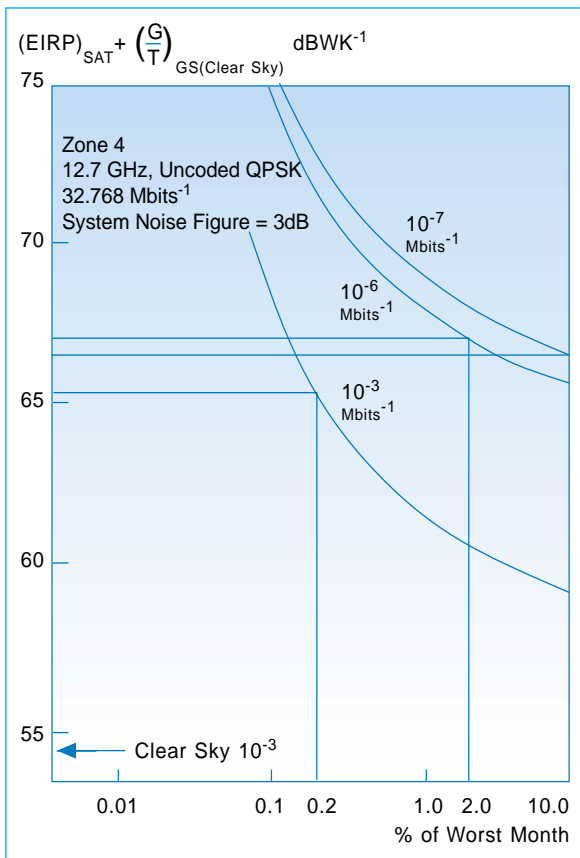


Figure 2 ([1] figure 3.3.6.1-4)  
Required downlink  $(EIRP)_{SAT} + (G/T)_{GS(clear\ sky)}$  to meet a specific BER for a given percentage of time (worst month)

The necessary 0.3 link margin on each link is not included.

Treating the OBP channel interference and noise sources as "equivalent" gaussian noise sources, together with the assumption that usable bandwidth is 1.2 times the symbol rate ([2], A10-6), leads to:

$$(C/N+I)_{up} \quad (5)$$

< 16.2 dB for less than 10 % of any month

< 15.4 dB for less than 2 % of any month

< 11.2 dB for less than 0.2 % of any month

$$(C/N+I)_{down}$$

< 16.0 dB for less than 10 % of any month

< 15.1 dB for less than 2 % of any month

< 10.3 dB for less than 0.2 % of any month

In an interference free environment,  $C/N+I$  equals  $C/N$ , and is given by

$$(C/N)_x = [EIRP_x + (G/T)_x] - L_x \quad (6)$$

$$- Att_{atmx} - 10\log(kB_x)$$

$$- Margin_x - Att_{rainx}$$

Where

$x$  - denotes either up or down

$EIRP$  - Transmit station Effective Isotropic Radiated Power (dBw)

$(G/T)$  - Receive station, figure of merit (dB/K)

$L$  - Free space attenuation (dB)

$Att_{atm}$  - Atmospheric absorption (dB)

$k$  - Boltzmann's konstant  $1.38 \cdot 10^{-23}$  (J/K)

$B$  - Bandwidth (Hz)

$Att_{rain}$  - Rain attenuation (dB)

In [2], the effect of rain attenuation is discussed, and the required  $[EIRP_x + (G/T)_x(clear\ sky)]$  to achieve a specific BER in this interference free environment is given as a percentage of time, figures 1 and 2. It can be noted that in this particular case, the  $BER = 1 \cdot 10^{-6}$  is the most critical one for uplink and downlink. However, with the addition

of the coding gain (assuming trellis 8-psk),  $BER = 1 \cdot 10^{-3}$  becomes the most critical on the downlink. The corresponding  $C/N$  is 15.4 and 10.3 dB on the up- and downlink, respectively. The chosen design criteria are ([2]):

$$[EIRP_{gs} + (G/T)_{sat}] \quad (7)$$

$$= 56.8 \text{ dBWK}^{-1}$$

$$[EIRP_{sat} + (G/T)_{gs(clear\ sky)}]$$

$$= 65.8 \text{ dBWK}^{-1}$$

## 2 C/N and C/I calculations

On a linear form, (6) can be rewritten:

$$(C/N)_x(\theta_t, \theta_r)$$

$$= \frac{EIRP_x(\theta_t) \cdot (G/T)_x(\theta_r)}{L_x \cdot Att_{atmx} \cdot k \cdot B_{xOBP} \cdot Margin_x \cdot Att_{rainx}} \quad (8)$$

Similarly  $C/I$  can be written:

$$(C/I)_{up}(\theta_t, \theta_r)$$

$$= \frac{EIRP_{up}(\theta_t) \cdot (G/T)_{sat}(\theta_r) \cdot T_{sat}}{I_{up} \cdot Margin_{up} \cdot Att_{rainup}}$$

$$= EIRP_{up}(\theta_t) \cdot B_{up} \quad (9)$$

where  $I$  is given by:

$$I = \sum_i I_i = \sum_j I_j + \sum_k I_k$$

$$I_j = \frac{EIRP_{upj}(\theta_{Is}) \cdot DEG_{upj} \cdot B_{upOBP} \cdot G_{rsclj}}{B_{uplj}}$$

$$I_k = \frac{EIRP_{upk}(0^\circ) \cdot DEG_{upk} \cdot B_{upOBP}}{B_{uplk} \cdot XPD_{upk}} \quad (10)$$

In a linear scale, the parameters are as follows:

$EIRP_x$

- effective power transmitted towards the receiver. On uplink this is assumed to be boresight EIRP, on downlink actual EIRP, depending on earth station position in downlink beam

$G/T_x$

- receive station figure of merit (linear). On uplink this is assumed to be actual  $G/T$ , depending on earth station position in uplink beam, on downlink boresight  $G/T$  is assumed

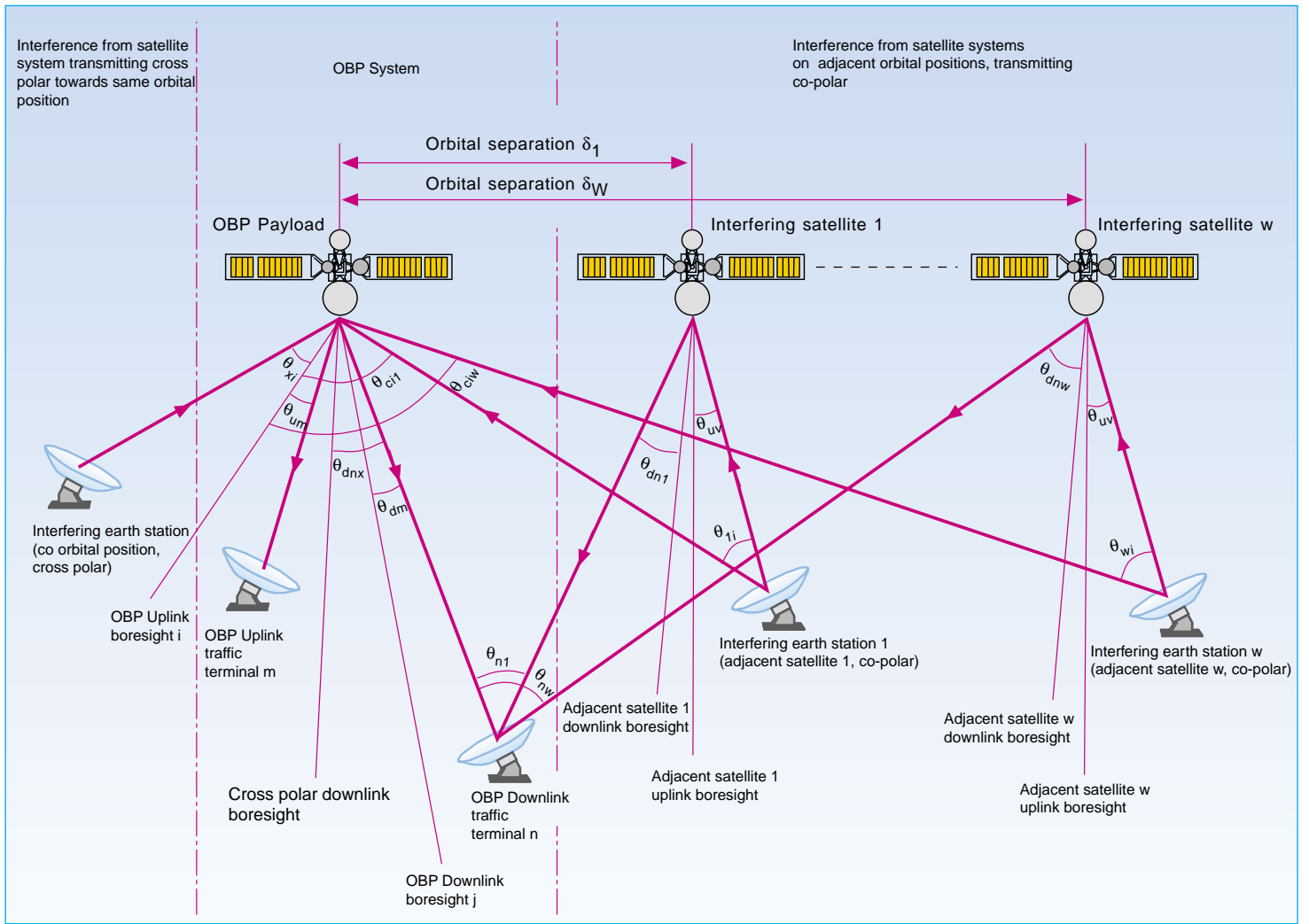


Figure 3 Interference model for calculating required OBP traffic terminal characteristics

$T_x$   
- noise temperature of receiving system

$$\sum_j I_j$$

- total received co-polar interference

$$\sum_k I_k$$

- total received cross polar interference

$EIRP_{upj/k}(\theta_{Is})$   
- effective interfering uplink power in direction of OBP payload

$DEG_{upj/k}$   
- degradation factor giving the increase of spectral power density at OBP uplink frequency compared to that of white noise interference in same channel bandwidth

$B_{upOBP}$   
- wanted signal uplink bandwidth

$G_{rscj}$   
- satellite co-polar receive gain in direction of interfering source j

$XPD_{upk}$   
- cross polar gain of interfering signal

$B_{uplj/k}$   
- interfering signal j/k bandwidth

$\theta$   
- the angle between the boresight of an antenna and the direction of the received/transmitted signal.

Equations (5), (8) and (9) in (1) then give the required boresight characteristics for the ground station:

$$EIRP_{gs}(0^\circ) = (C/N + I)_{up} + 10 \cdot \log \left[ \frac{A_{up} + B_{up}}{A_{up} \cdot B_{up}} \right] \quad (11)$$

### 3 Interference characteristics

#### 3.1 Interfering sources

Interfering sources can be satellite systems operating either in the same orbital position, or in an adjacent orbital position as well as terrestrial systems (e.g. radio-relay systems). Interference can be both co- and cross-polar, and from systems operating on the same frequency, or at an adjacent channel.

In this study, it is assumed that both cross polar and adjacent channel interference from satellite systems operating on adjacent orbital positions is

suppressed sufficiently to be negligible. Likewise it is assumed that it is possible to make the necessary precautions to avoid adjacent channel interference from the same orbital position (same satellite owner).

Interference from terrestrial systems could be a problem that would affect terminal design, especially in cases of low interference from satellite systems. Calculations should therefore be performed to determine its impact on required terminal characteristics. However, this kind of interference is not dealt with here. In [7], maximum terrestrial system EIRP is set to +55 dBW, and in the case of EIRP > +45 dBW, the antenna boresight should be more than 1.5° from the geostationary orbit. Typical radio-relay systems use antennas 1.8 m, or larger, and have a bandwidth of at least 10 times that of the OBP system, this would mean an antenna suppression of at least 20 - 25 dB combined with a spreading effect of spectral power density due to the larger bandwidth. It is also understood that the Ku-band uplink frequencies are not commonly used for radio-relay systems, some

bands are not at all assigned for terrestrial systems. This leads to the assumption that terrestrial interference is probably not a problem on the uplink. On the downlink, interference from terrestrial systems will be a problem only to a limited number of terminals on certain geographical sites, and is therefore not considered in this study.

The interference considered to affect the OBP system, is therefore:

- Systems operating on an orthogonal polarisation in the same frequency band towards the same orbital position
- Systems operating on the same polarisation in the same frequency band towards an adjacent satellite.

This interference model for calculating the OBP traffic terminal requirements, is shown in figure 3.

### 3.2 Propagation considerations

On the uplink, the interfering stations will typically not have the same rain-fade pattern as the OBP traffic terminal. The physical separation will give uncorrelated fading between the various stations. To give a correct picture of the uplink conditions, it is therefore necessary to calculate the  $(C/I)_{up}$  taking into account the independent and possibly different rain-fade patterns. However, for the sake of simplicity, and because it is believed to be of little effect, the worst case is used in this study. Rain attenuation is consequently set to zero on the interfering uplinks. (On 20/30 GHz where rain attenuation is higher, this may not be correct, but this study is concerned only with Ku-band.) On the downlink, all signals will have more or less the same attenuation pattern since they are all received by the same earth station, and the rain attenuation is assumed to be the same for all incoming signals.

The minimal acceptable  $[EIRP_{gs} + (G/T)_{sat}]$ , and the critical  $C/N + I$  inserted in equation (6), will give the corresponding critical rain attenuation.

On the uplink, all earth stations capable of interfering with the OBP payload, are within the coverage of the small satellite spot beam. On the downlink, all interfering satellites will be in an orbital position not far from the OBP payload. Atmospheric attenu-

ation and free space attenuation is therefore assumed to be the same for all signals on the up- and downlink, respectively.

### 3.3 Cross polar interference

Cross polar interference is generated both in the transmitting and the receiving antennas, as well as in the depolarisation on the link. Total XPD on the uplink is given by the expression:

$$XPD_{up} = \delta G_{tgsx}(\theta) \cdot \delta G_{rsc}(\theta) + \delta G_{tgsx}(\theta) \cdot \delta G_{rsc}(\theta) + \delta G_{tgsx}(\theta) \cdot DEPOL_{up} \cdot \delta G_{rsc}(\theta) \quad (12)$$

(linear)

Where  $x/c$  means cross- and co-polar antenna gains, respectively, and  $t/r$  in transmit/receive direction. Cross-polar interference is assumed to come from systems operating on the same orbital position, and ground station antennas are therefore represented with boresight values.  $G_{tgsx}$  is assumed to be 30 dB below  $G_{tgsx}$  (WARC), hence  $10^{-3} \cdot G_{rsc}(\theta)$ .

The depolarisation (DEPOL) is the cross polar to co-polar ratio at the receive end of the link with no cross-polar component at the transmit end. From "Radio Regulations" it is assumed to be:

$$DEPOL = 10^{-\frac{1}{10}[30 \cdot \log f - 40 \cdot \log(\cos \phi_{el}) - 20 \cdot \log Att_{rain}]} \quad (13)$$

Where  $f$  is frequency in GHz,  $\phi_{el}$  elevation angle

$$DEPOL(12.5 \text{ GHz}, 25^\circ, 1.1 \text{ dB}) = 33.8 \text{ dB} = 418 \cdot 10^{-6}$$

### 3.4 Interference spectral distribution

#### 3.4.1 TV-signals

"Typical" analogue FM TV signals are assumed to have a cosine square power distribution over the channel bandwidth.

$$P(f) = P(f_0) \cdot \cos^2\left(\frac{f_0 - f}{B} \cdot 2 \cdot \frac{\pi}{2}\right) \quad (14)$$

$$\text{for } f_0 - \frac{B}{2} < f_0 - f < f_0 + \frac{B}{2}$$

Where  $P(f_0)$  is the power spectral density (W/Hz) at centre frequency  $f_0$ , and  $B$  is RF signal bandwidth. The signal EIRP is given by:

$$EIRP = \int_{f_0 - B/2}^{f_0 + B/2} P(f) df \quad (15)$$

Equation (14) can thus be rewritten:

$$P(f) = EIRP \cdot \frac{2}{B} \cdot \cos^2\left(\frac{f_0 - f}{B} \cdot \pi\right) \quad (16)$$

$$\text{for } f_0 - \frac{B}{2} < f_0 - f < f_0 + \frac{B}{2}$$

$EIRP/B$  is the power density when assuming the signal uniformly distributed over the bandwidth. The rest therefore can be regarded a correction factor, or a degradation factor compared to white noise. In decibel scale this degradation factor with the above assumptions becomes:

$$DEG_{TV}(f) = -10 \cdot \log\left[2 \cdot \cos^2\left(\frac{f_0 - f}{B} \cdot \pi\right)\right] \quad (17)$$

$DEG_{TV}(f)$  is shown in figure 4. It can be seen that for signals more than  $0.25 \cdot B$  from the centre frequency, the spectral power of the interfering TV signal becomes lower than the "white noise EIRP". For a 27 MHz TV signal this corresponds to  $f_0 \pm$  more than 10 MHz.

#### 3.4.2 Digital TDM

Digital single carrier TDMA systems will typically use QPSK. The corresponding power spectral distribution is given by:

$$P_{TDMA}(f) = P_{TDMA}(f_0) \cdot \left[ \frac{\sin(2 \cdot \pi \cdot (f_0 - f) \cdot T_b)}{2 \cdot \pi \cdot (f_0 - f) \cdot T_b} \right]^2$$

$$\text{for } f_0 - i \cdot \frac{1}{4 \cdot T_b} < f_0 - f < f_0 + i \cdot \frac{1}{4 \cdot T_b}, i)1 \quad (18)$$

$1/T_b$  is the bitrate which is twice the symbol rate.  $P_{TDMA}(f_0)$  is power spectral density at centre frequency.

Before transmission, this signal is usually filtered in some kind of square root cosine filter, with a frequency response  $R(f,a)$ :

$$R(f,a) = \begin{cases} 0 & |f_0 - f| > \frac{1+a}{4T_b} \\ \cos^2\left[\frac{\pi}{4a}(|f_0 - f| - (1-a))\right] & \frac{1-a}{4T_b} < |f_0 - f| < \frac{1+a}{4T_b} \\ 1 & |f_0 - f| < \frac{1-a}{4T_b} \end{cases} \quad (19)$$

$a$  is the roll-off factor, typically in the range of 0.4 - 0.5.  $R(f,a)$  for  $a = 0.4$  is shown in figure 5. Transmitted power distribution is:

$$P(f) = P_{TDMA}(f) \cdot R(f) \quad (20)$$

The total signal EIRP is found in a similar way as in (15), and (18) can be rewritten:

$$P(f) = \frac{EIRP}{i \cdot \frac{1}{2T_b}} \cdot \frac{i \cdot \frac{1}{2T_b}}{f_0 + i/4T_b} \cdot x(f)^2 \quad (21)$$

Where  $x(f) = [(\sin(2\pi(f_0 - f)T_b)) / (2\pi(f_0 - f)T_b)] \cdot R(f)$ .  $EIRP/(i \cdot 1/2T_b)$  is the "corresponding" white noise density over the signal bandwidth  $i \cdot 1/2T_b$ . The degradation factor then becomes:

$$DEG_{TDMA}(f) = 10 \cdot \log \left[ \frac{i \cdot \frac{1}{2T_b}}{f_0 + i/4T_b} \cdot x(f)^2 \right] \quad (22)$$

$DEG_{TDMA}(f)$  for  $a = 0.4$  and  $0.5$  are shown in figure 5. It can be seen that TDMA signals have more evenly spread spectrum than analogue TV signals. For frequencies more than 0.27 times signal bandwidth off the centre frequency, power density becomes less than that of white noise with the same EIRP.

### 3.4.3 Multicarrier

For interference from multicarrier type of systems, a scenario of 64 kbit/s SMS type of carriers with identical boresight EIRP is envisaged. From [2] it is assumed that transponders with this type of traffic can be assumed to have an evenly spread spectral density because of the considerably larger bandwidth of the OBP signals. Thus, spectral density is given by:

$$P(f) = P = \frac{EIRP}{BW} \quad (\text{linear}) \quad (23)$$

Where  $EIRP$  is the boresight EIRP per carrier, and  $BW$  is the carrier separation.

### 3.5 Interference power levels

Interfering systems are assumed to operate in compliance with the CCIR maximum power levels [8] giving  $EIRP_{up}$  at centre frequency:

$$EIRP_{up/40 \text{ kHz}}(\theta) = 39 - 25 \cdot \log(\theta) \text{ dBW/40 kHz} \quad (24)$$

Total  $EIRP_{up}$  is given by:

$$EIRP_{up} = EIRP_{up/40 \text{ kHz}} - 10 \cdot \log(40 \text{ kHz}/B_{up}) - \text{DEG} \quad (25)$$

Thus giving:

$$EIRP_{up}(\theta) = 39 - 25 \cdot \log(\theta) - 10 \cdot \log(40 \text{ kHz}/B_{up}) - \text{DEG} \quad (26)$$

Where  $B_{up}$  and DEG is given by the interfering signal characteristics. Multicarrier systems are assumed to have the same degradation factor as TDMA systems when calculating total EIRP per carrier.

### 3.6 Interfering systems in the orbital arc

The OBP payload is planned for launch some time in the late nineties. It is difficult to predict the exact interference scenario at that time, especially the uplink interference within a rather narrow frequency band, and small geographical area which is the interference of concern to the OBP payload. Through proper frequency planning and choice of spot beam configuration, the interference level may be considerably reduced. The interference scenario is expected to vary a great deal along the orbital arc, and by proper choice of orbital location of the OBP payload, the technical requirements for the earth stations could be reduced.

Figure 7 gives an estimate of the utilisation of the geostationary orbit over Europe in early 1997 for the 14.0 - 14.5 GHz uplink band. It can be seen that satellites are concentrated in three major areas; the INTELSAT AOR positions in approx. 18 - 35 degrees west, the INTELSAT IOR positions in 57 - 66 degrees east, and the EUTELSAT positions in 3 - 22 degrees east. Between these three groups of satellites, there will be two areas with considerably lower satellite density.

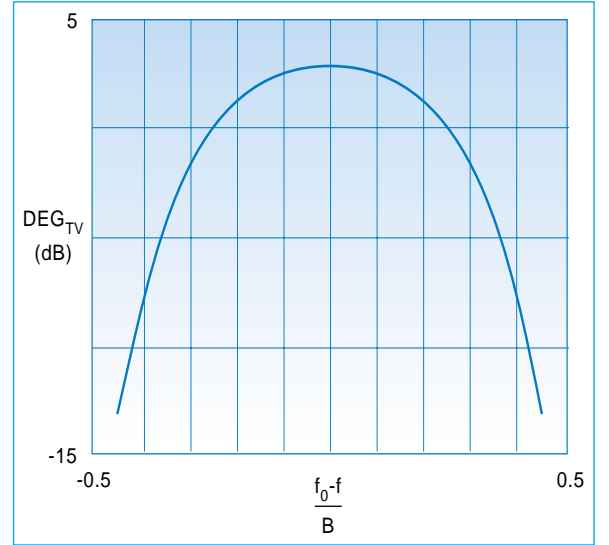


Figure 4 Degradation factor for TV signal relative to white noise in the same channel bandwidth, with the same EIRP

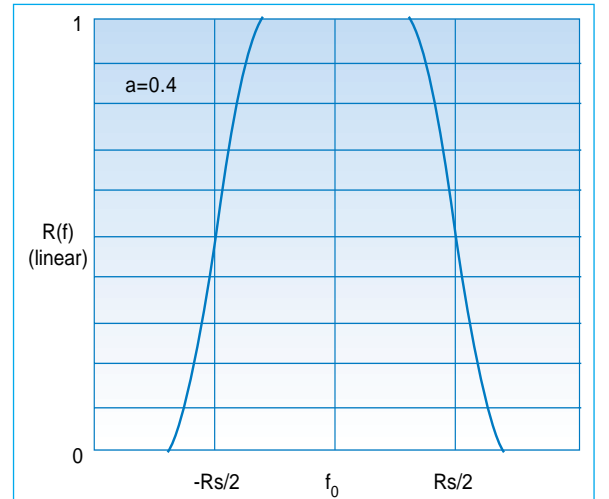


Figure 5 Square root raised cosine response with roll-off factor  $a = 0.5$

It is, however, not possible to envisage the interference scenario from these estimates with the required certainty, to perform a calculation of OBP earth station requirements as a function of payload orbital position. This overview of the utilisation of the geostationary orbit therefore is only used for information, while calculations are performed for specific interference configurations.

## 4 Ground station characteristics

### 4.1 Ground station antennas

All antennas are supposed to perform like the WARC receive satellite anten-

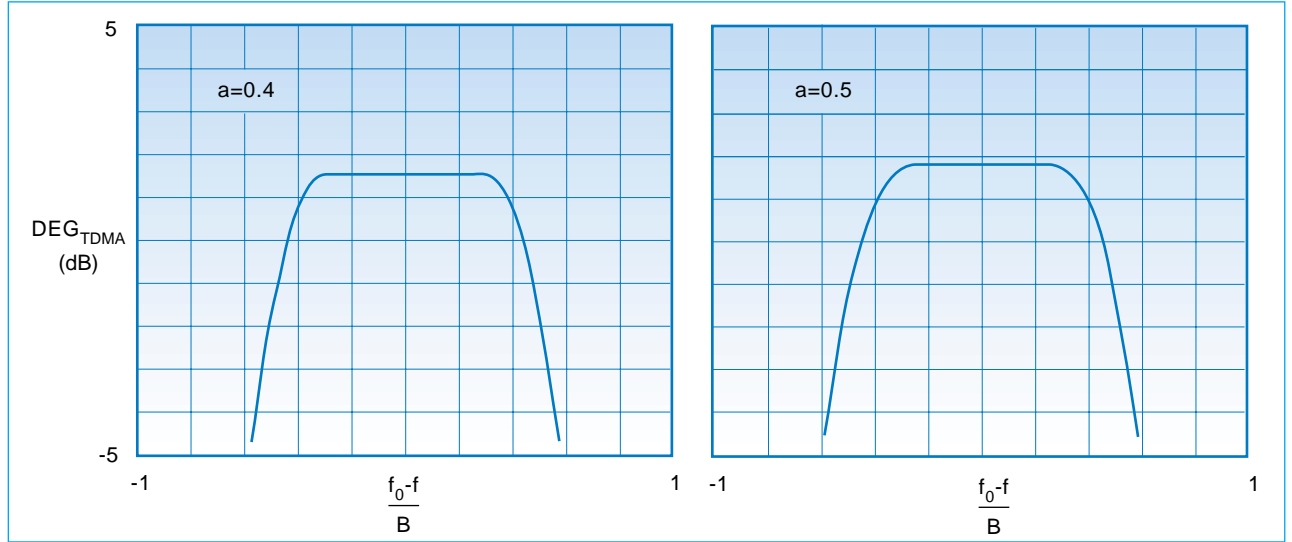


Figure 6 Degradation factor for TDMA signal, relative to white noise in the same channel bandwidth, with the same EIRP

nas [4], when no other information is available (e.g. satellite antenna coverage diagrams):

$$G_c(\theta) = G_c(0^\circ) \cdot 10^{-1.2 \left[ \frac{\theta}{\theta_0} \right]^{2*}}$$

$$G_c(\theta) = G_c(0^\circ) \text{ (linear)}$$

$$G_c(\theta) = G_c(0^\circ) \cdot 10^{\frac{1}{10} \left[ -17.5 - 25 \cdot \log \left( \frac{\theta}{\theta_0} \right) \right]^{**}}$$
(27)

\* for  $\theta < \frac{\theta}{\theta_0} < 1.3$

\*\* for  $\frac{\theta}{\theta_0} > 1.3$

$$G_x(\theta) = G_c(0^\circ) \cdot 10^{\left[ -3 - 1.2 \cdot \left( \frac{\theta}{\theta_0} \right)^2 \right]^{***}}$$

$$G_x(\theta) = G_c(0^\circ) \cdot 10^{-3.3^{**}}$$

$$G_x(\theta) = G_c(0^\circ) \cdot 10^{\left[ -4 - 4 \cdot \log \left( \frac{\theta}{\theta_0 - 1} \right) \right]^{****}}$$
(28)

\*\*\* for  $0 < \frac{\theta}{\theta_0} < 0.5$

\*\*\*\* for  $0.5 < \frac{\theta}{\theta_0} < 1.67$

\*\*\*\* for  $\frac{\theta}{\theta_0} > 1.67$

where:

$G_c(\theta)$  = co-polar linear absolute antenna gain

$G_x(\theta)$  = cross-polar linear absolute antenna gain

$$G(0) = \eta \cdot \left( \frac{\pi \cdot f \cdot D}{c} \right)^2$$
(29)

= co-polar linear boresight gain,  
D antenna diameter (m)  
 $\eta$  antenna efficiency  
 $0 < \eta < 1$

$$\theta_0 = 1.16 \cdot \frac{c}{f \cdot D} \cdot \frac{180}{\pi}$$
(30)

= 3 dB beamwidth, assuming  
aperture distribution  
 $0.5 + 0.5 \cdot (1 - r^2)^2$

#### 4.2 Up-link EIRP

Up-link boresight EIRP is given by:

$$EIRP_{up}$$
(31)

$$= 10 \cdot \log \left[ \frac{G_{Igs}(0) \cdot P_{up}}{Att_{feedtx}} \right]$$

$$= 10 \cdot \log \left( D_{gstx}^2 \cdot M \right) (dBW)$$

$P_{up}$  = Ground station HPA power (W)

$Att_{feedtx}$  = feed and antenna tx loss, in linear scale.

#### 4.3 Ground station G/T

Receive terminal noise is calculated from the model shown in figure 8.

Antenna receive noise temperature is given as:

$$T_A = [(1 - P_S) \cdot T_t + P_S \cdot T_0 + (1 - 1/Att_{rain down}) T_R] \text{ (K)}$$
(32)

$P_S$  = portion of sidelobes towards ground (typically 0.05)

$T_t$  =  $T_t$  (atmosphere, galactic noise, ...) =  $T_t(f, \theta_{elevation})$   
[ $T_t(12.5 \text{ GHz}, 17^\circ) \approx 15 \text{ K}$ ]

$T_0$  = 290 K

$T_R$  = rain temperature

Total system noise is given by:

$$T_{gs} = T_A \cdot Att_{feed} + (1 - Att_{feed}) T_0 + T_R$$
(33)

$Att_{feed}$  = feed and antenna losses in a linear scale

$T_R$  =  $(F_R - 1) T_0$   
= receiver noise temperature

$F_R$  = receiver noise figure, linear

Thus, giving ground station G/T:

$$(G / T)_{gs}$$
(34)

$$= 10 \cdot \log \left[ \frac{G_{gs}(0)}{Att_{feedrx} \cdot T_{gs}} \right]$$

$$= 10 \cdot \log \left( D_{gsrx}^2 \cdot N \right) (dBK^{-1})$$

#### 4.4 Ground station antenna diameter

The effect of interference on the OBP terminals is that  $EIRP_{up}$  has to be increased compared to the interference free cases. This can either be done by increasing the antenna diameter, or the HPA power.

Traffic terminals are characterised by the antenna diameter required to meet the quality requirements in CCIR Rec. 614. HPA power is in this study kept fixed. Up- and downlink calculations will give different antenna diameters.



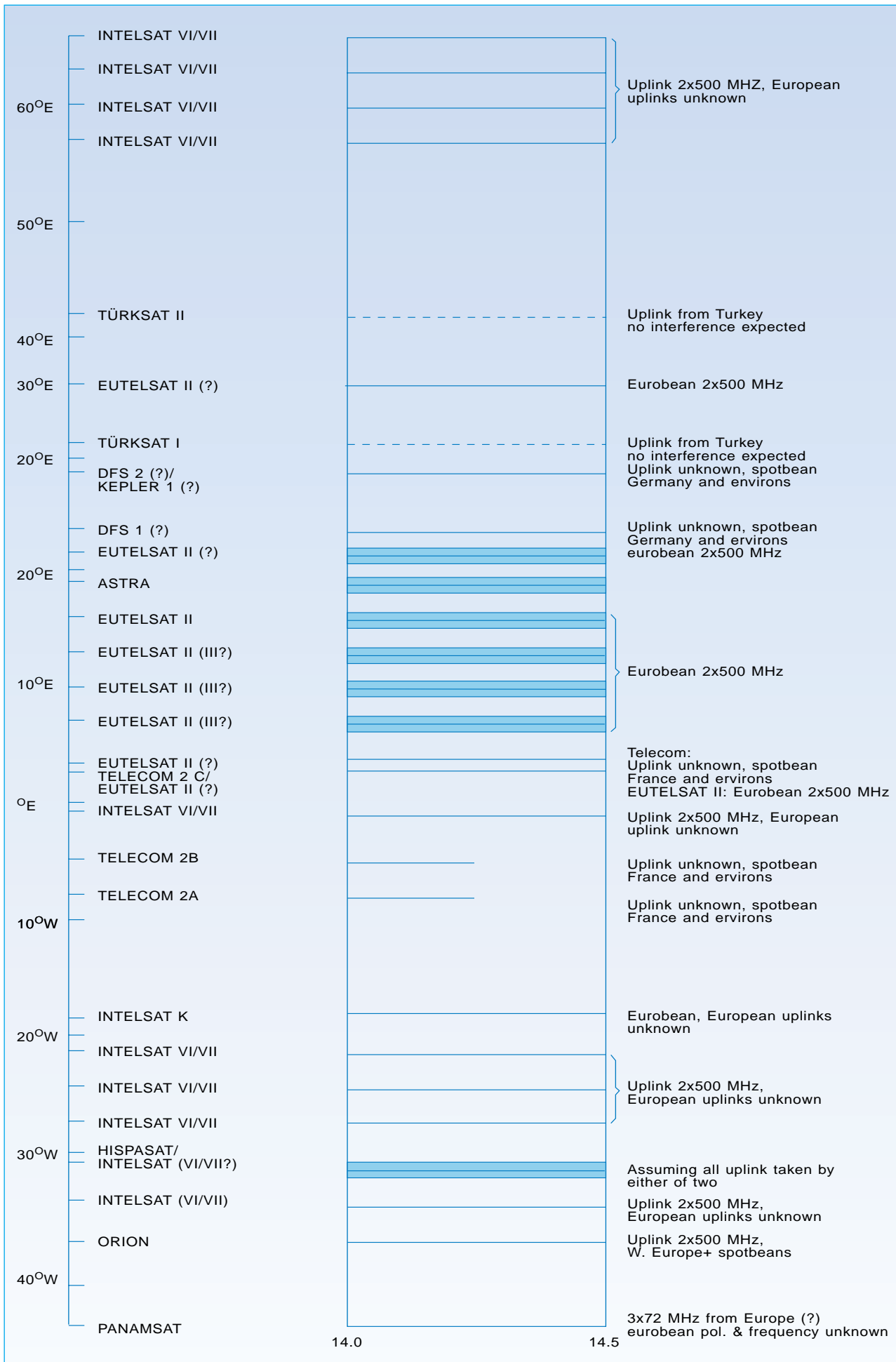


Figure 7 Possible utilisation of the geostationary orbit over Europe in early 1997 for the 14.0 - 14.5 GHz uplink band

The largest one will give the minimal acceptable diameter.

Equation (31) can be rewritten to give the required uplink antenna diameter:

$$D_{gstx} = \left( \frac{1}{M} \cdot 10^{\frac{1}{10} EIRP_{up}} \right)^{\frac{1}{2}} \quad (35)$$

Where required EIRP<sub>up</sub> is given by equation (11).

Similarly, the downlink antenna diameter can be found from equation (34) to be:

$$D_{gsrx} = \left[ \frac{1}{M} \cdot 10^{\frac{1}{10} (G/T)_{gs}} \right]^{\frac{1}{2}} \quad (36)$$

Where required (G/T)<sub>gs</sub> is given by the clear sky interference free conditions in (7).

To characterise the OBP traffic terminal requirements, minimum antenna diameter should be determined for all the interference cases found applicable. Space segment characteristics, and all other ground station characteristics, should be kept the same throughout the study.

## 5 Assumptions for calculating OBP terminal characteristics

Assumptions are mainly those given in [2].

### 5.1 OBP signal and propagation characteristics

$$\begin{aligned} f_{up} &= 14.5 \text{ GHz} \\ f_{down} &= 12.5 \text{ GHz} \\ n &= 1.2 \quad n = \text{bandwidth/symbol rate} \\ B_{upOBP} &= 1.2 \text{ MHz} \quad 2 \text{ Mbit/s QPSK} \end{aligned}$$

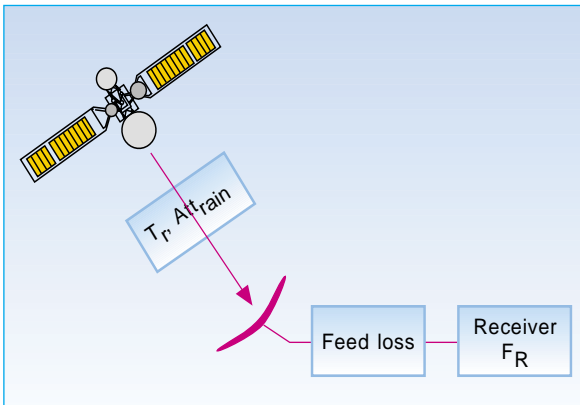


Figure 8 Model for calculating ground station noise temperature

$$C/(N+I)_{up} = 15.4 \text{ dB}$$

$$Att_{rainup} = 1.1 \text{ dB} \quad \text{Rain attenuation corresponding to critical } C/(N+I)$$

$$Margin = 0.3 \text{ dB}$$

$$L_{up} = 207.1 \text{ dB}$$

$$L_{down} = 206.0 \text{ dB}$$

$$Att_{atmup} = 0.3 \text{ dB}$$

$$Att_{atmdown} = 0.2 \text{ dB}$$

### 5.2 OBP payload assumptions

$$G/T = 9 \text{ dBK}^{-1} \quad \text{Edge of coverage } G/T$$

$$EIRP = 44.7 \text{ dBW} \quad \text{Down-link boresight EIRP per carrier}$$

$$G_{rsc eoc} = 36 \text{ dB} \quad \text{Edge of coverage receive gain}$$

$$Att_{feedrx} = 1.5 \text{ dB} \quad \text{Receive feed loss}$$

$$\begin{aligned} T_s &= (G_{rsc eoc}) / (Att_{feedrx} G/T) \\ &= 355 \text{ K} \quad \text{Satellite noise temperature} \end{aligned}$$

### 5.3 OBP terminal assumptions

$$n = 0.65 \quad \text{Antenna efficiency}$$

$$P_{up} = 12 \text{ W} \quad \text{HPA power}$$

$$Att_{feedtx} = 1 \text{ dB}$$

$$Att_{feedrx} = 1 \text{ dB}$$

### 5.4 Interference characteristics

$$\delta G_{rsc} = 0 \text{ dB} \quad \text{Interfering sources in boresight}$$

$$\delta G_{rsx} = 0 \text{ dB}$$

$$XPD = 26.2 \text{ dB}$$

$$B_{up TV} = 27 \text{ MHz} \quad \text{TV signal bandwidth}$$

$$B_{up TDMA} = 72 \text{ MHz} \quad 120 \text{ Mbit/s QPSK, } n = 1.2$$

$$B_{up multi} = 64 \text{ kHz} \quad \text{Channel separation SCPC system}$$

$$f_{0 adj} = f_{0 OBP} \quad \text{Adjacent satellite interference at centre frequency}$$

$$\begin{aligned} f_{0 XPD TV} &= f_{0 OBP} + 18 \text{ MHz} \\ &\quad \text{Cross polar TV interference centre frequency, (Assuming staggered transponders/36 MHz transp.)} \end{aligned}$$

$$\begin{aligned} f_{0 XPD TDMA} &= f_{0 OBP} + 36 \text{ MHz} \end{aligned}$$

Cross polar TDMA interference centre frequency, (72 MHz transp.)

$$DEG_{TV} = 3 \text{ dB}$$

Degradation factor relative to white noise with same EIRP in same channel bandwidth. (see chap. 3.4)

$$DEG_{TDMA} = 1.5 \text{ dB}$$

$$G_{rsc b} = 42 \text{ dB} \quad \text{Satellite boresight receive gain, interfering sources in boresight.}$$

This means that off axis EIRP is determined by:

$$\begin{aligned} EIRP_{up}(\theta) &= 64.3 - 25 \cdot \log(\theta) \text{ (dBW) for TV} \\ &= 70.1 - 25 \cdot \log(\theta) \text{ (dBW) for TDMA} \\ &= 39.5 - 25 \cdot \log(\theta) \text{ (dBW) per carrier for multicarrier} \\ &= 54.5 - 25 \cdot \log(\theta) \text{ (dBW) total within OBP uplink (100 \% fill)} \end{aligned} \quad (37)$$

Multicarrier systems may typically use small earth stations with a limited number of carriers per station. In [2] a typical SMS carrier is seen to have a boresight EIRP of 52 dBW per 64 kbit/s carrier. If it is assumed that an 1.8 metre antenna with a radiation diagram, as shown in figure 9, is used for these transmissions, the off axis EIRP will be:

$$\begin{aligned} EIRP_{up}(\theta) &= 29 - 25 \cdot \log(\theta) \text{ (dBW) per carrier for multicarrier} \\ &= 44 - 25 \cdot \log(\theta) \text{ (dBW) total within OBP uplink (100 \% fill)} \end{aligned} \quad (38)$$

This latter estimate of multicarrier earth station off axis EIRP appears to be more realistic, calculations should also be performed with these values, giving approximately 10 dB lower interference levels than maximum permissible level from CCIR.

Since it is shown that CCIR limits may give unrealistic high off axis EIRPs for multicarrier, this may also be the case for TV and TDMA. Calculations for

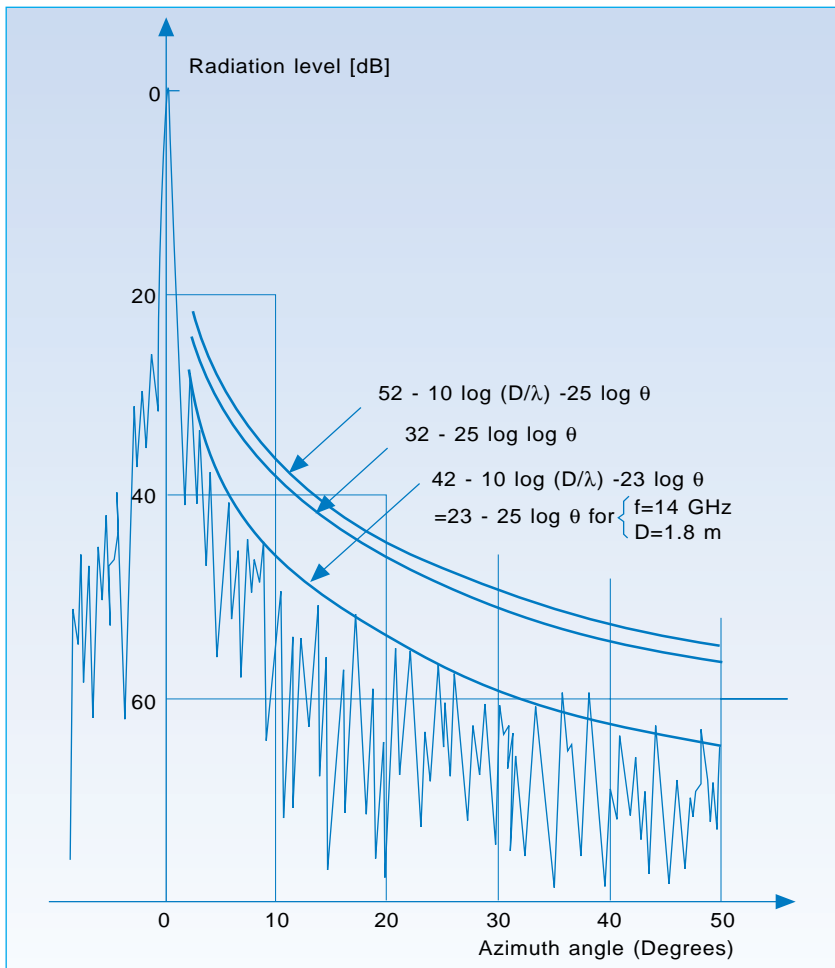


Figure 9 Measured azimuth wide angle radiation pattern for 1.8 m shaped offset antenna. Reference curves for antenna characteristics are shown for comparison

	I+W	A+W	I+P	A+P
No int.	0.6	0.4	0.6	0.4
TV 3°	5.2	3.3	1.7	1.1
TDMA 3°	5.2	3.3	1.7	1.1
Multi 3°	4.8	3.0	1.5	0.9
TV 6°	2.4	1.5	1.0	0.6
TDMA 6°	2.4	1.6	1.0	0.6
Multi 6°	2.0	1.3	0.9	0.6
TV 9°	1.4	0.9	0.7	0.5
TDMA 9°	1.5	0.9	0.7	0.5
Multi 9°	1.3	0.9	0.7	0.5
TV XPD 0°	6.4	4.5	-	-
TDMA XPD 0°	3.3	2.4	-	-
Multi XPD 0°	3.7	2.7	-	-

Table 1 Required OBP terminal antenna diameter as a result of one single interfering uplink signal. Adjacent satellite interference is assumed to be co-polar while interference towards the same orbital position is cross polar

Initial coverage assumptions (I):

- edge of coverage at -6 dB contour
- interfering sources in boresight

Worst case off-axis EIRP's (W)

- max. permissible according to CCIR

Alternative coverage assumptions (A):

- edge of coverage at -3 dB contour
- interfering sources at -1 dB contour

More probable off-axis EIRP's (P):

- off-axis EIRP's 10 dB down from W

these kinds of interference should also be performed with off axis EIRP 10 dB down.

In the calculations, it is assumed that the edge of coverage will be at the -6 dB contour of the satellite receive beam. For some constellations, this might be a little bit low. Calculations therefore should be performed also with the -3 dB contour as the edge of coverage.

## 6 Results

It is not possible to give an estimate of the uplink interference scenario from within each of the narrow OBP spot beams. Calculations have therefore been performed by investigating the effect of one single interference contribution. The results from these calculations are given in table 1 and figure 10. It should be noted, however, that these results are achieved by using the method described in this article.

It can be seen that the OBP system is very sensitive to cross polar interference. It is therefore essential that the OBP operator has full control of the utilisation of the orthogonal polarisation in the same frequency band for the same orbital position, e.g. by using both polarisations in the same band for OBP purposes.

For adjacent satellite interference, it can be seen that without any precautions taken, interfering satellites have to be at least 9° away in order to meet the design goal of OBP antennas smaller than 2 metres, using solid state amplifiers. By shrinking the coverage area from the -6 to the -3 dB contour, required antenna size can be reduced by approximately 35%. Off axis EIRP of the interfering earth stations will directly affect the OBP terminals. This is something that is beyond the OBP operator's control, and relying on lower off axis EIRPs than specified by CCIR may therefore not be recommended.

The OBP system is seen to be sensitive to adjacent satellite interference. Since the probability for this interference will vary a lot along the geostationary arc, as may be seen from figure 7, the choice of orbital position should if possible be in an area with few adjacent satellites, thus reducing the risk of interference.

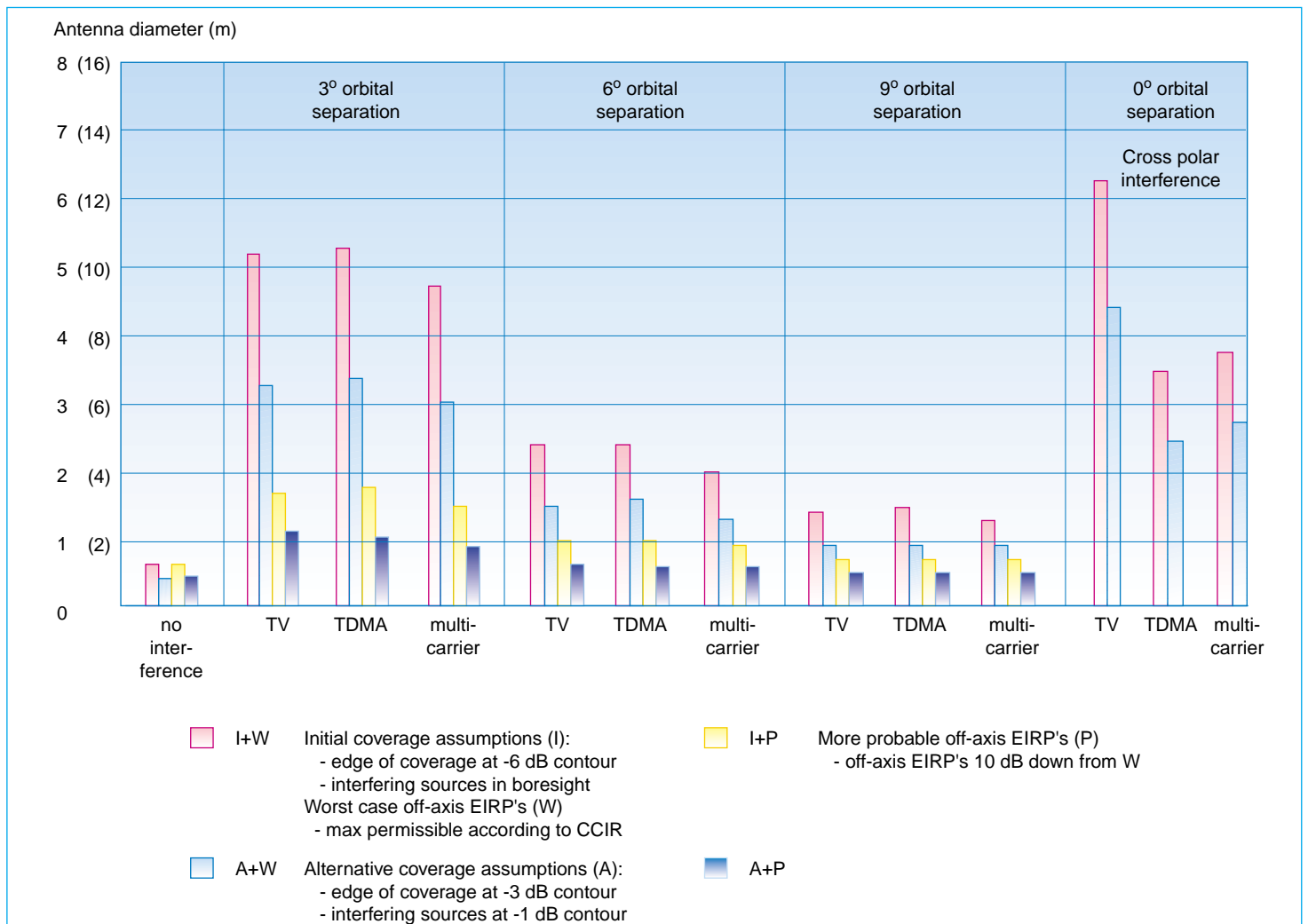


Figure 10 Required OBP terminal uplink antenna diameter (m) to meet the interference from one satellite interferer. Antenna diameters are calculated assuming a 12 W SSPA HPA, numbers in parentheses for a 3 W HPA

## 7 Conclusions

The method described in this article shows that without any precautions taken, the effect of one single interferer may be the need to increase OBP terminal antenna diameter by up to 10 times, probably making the system commercially uninteresting. It can be seen that there are a number of possibilities to reduce this interference down to an acceptable level. It is, however, evident that for this kind of system, interference should be one of the major concerns when determining system characteristics.

## 8 References

- 1 *EUTELSAT III Phase 1 Study Report*, chap. 3, Network and transmission aspects.
- 2 *EUTELSAT III Phase 1 Study Report*, Annex 10, On-Board Processing Link Budgets and Interference Constraints.
- 3 *EUTELSAT III Phase 1 Study Report*, chap. 5, Satellite and launch vehicle.
- 4 *Radio Regulations*, Appendix 30A, (Orb 88).
- 5 Rudge et al. *The Handbook of Antenna Design*, IEE (Peter Peregrinus), 1982.
- 6 *CCIR Rec. 614*, Volume IV.
- 7 *CCIR Rec. 406-6*, Volume IV and IX.
- 8 *CCIR Rec. 524-3*, Volume IV.

# Earth station antenna technology

BY ARNFINN NYSETH AND SVEIN A SKYTTEMYR

## 1 Introduction

Norwegian Telecom Research (NTR) has for many years been engaged in developing different earth station antennas, in co-operation with other research institutes and Norwegian industry.

The applications are business communications (VSAT), satellite TV up-link and receive only, and mobile satellite communications.

In the early 1980s a synthesis method for offset dual-reflector antennas was developed, and 3.3 m and 1.8 m antennas were produced. Later smaller antennas of the same type have been used for satellite TV reception. These antennas have been successfully produced and marketed by the Norwegian company Fibo-Støp.

In the last 3 years NTR has developed flat plate antennas for mobile satellite communications. Some of these antennas will be manufactured by ABB NERA.

## 2 Shaped offset dual-reflector antennas

### 2.1 Introduction

Since 1980 Norwegian Telecom Research (NTR) has constructed and built many different shaped offset dual-reflector antennas (1). The unique synthesis method developed at NTR for construction of such antennas, was presented at the ICAP conference in 1981 by G. Bjøntegaard and T. Pettersen (2) and later published in (3) and (4).

### 2.2 Synthesis and analysis method

A good description of the synthesis method can be found in (2), (3) and (4), and we will therefore not describe it in detail. The goal of the method is to obtain a prescribed aperture distribution, giving the wanted radiation pattern with high gain, low sidelobes, or a combination with rather high gain and quite low sidelobes. This goal can be obtained by shaping the sub- and main-reflectors, and in this way let them have small deviations from the original confocal system (with parabolic and elliptical or hyperbolic surfaces of revolution). The method also gives a low cross polarisation.

The synthesis is based upon Geometrical Optics (GO), and when using this method the diffraction effects are not included. The radiation pattern including these effects can be found by a Physical Optics (PO) analysis.

Figure 1 shows the GO rays in a 3.3 m antenna. It is possible to see the shaping of the aperture distribution by the varying distances between the rays.

### 2.3 Production of earth station antennas

The first offset dual-reflector antenna was built in 1981, and a few years later production started at Raufoss. Their production technique was based on composite materials on an aluminium honeycomb structure. The technique fulfilled the requirements and Raufoss produced several 3.3 m and 1.8 m

621.396.67

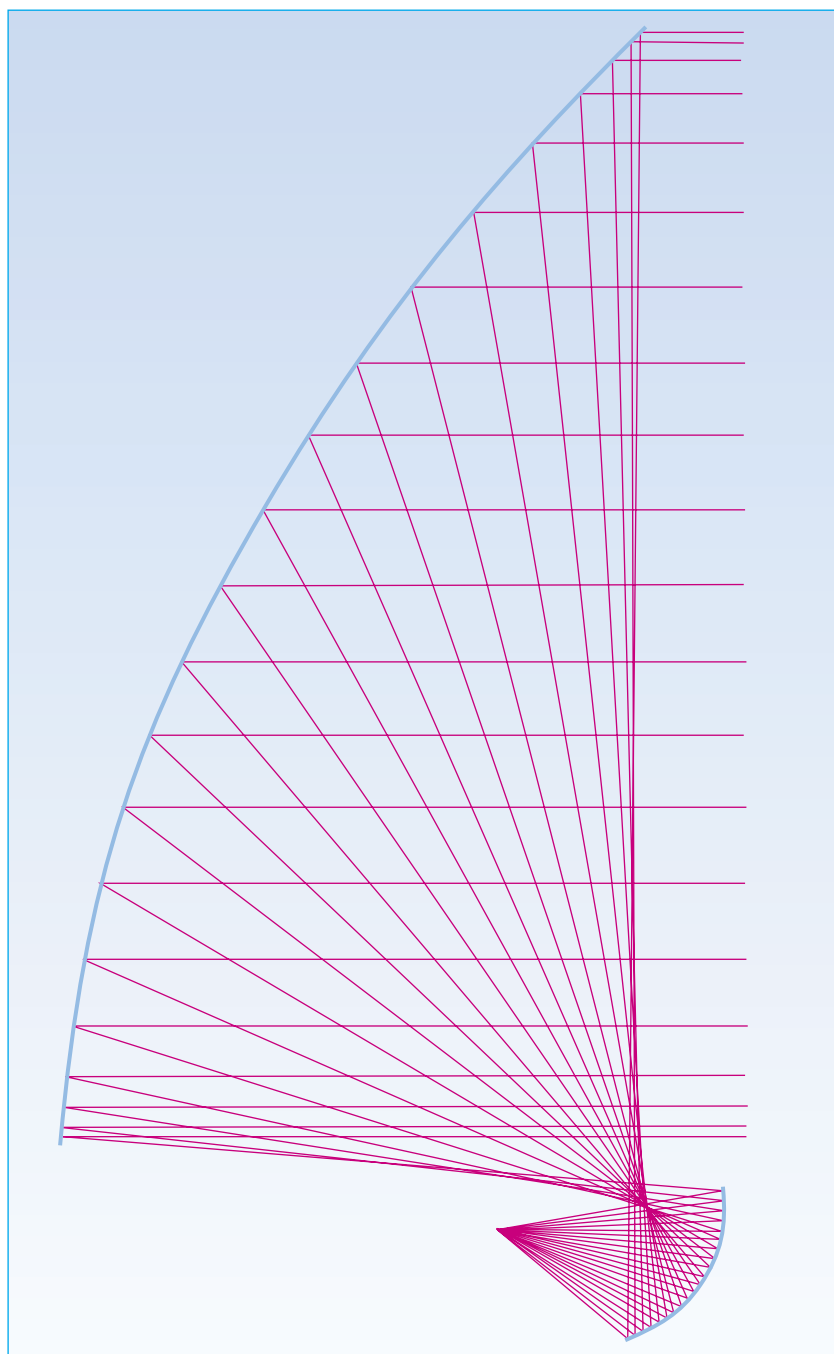


Figure 1 3.3 m antenna with GO ray-path

antennas up to 1987, but the production method was too expensive to produce antennas in large numbers. Figure 2 shows a 1.8 m antenna on a transportable earth station.

In 1988 the production was transferred to EB-NERA (now ABB-NERA). The reflectors are produced at Ticon in Drammen. They use polyester with glass fibre as material, and are able to produce the antennas cheaper. At the moment, they only produce 3.3 m antennas.

These antennas are intended for Ku-band (11/14 GHz), but with a modification of the feed horn they can be used at other frequency bands (12/18 GHz or 4/6 GHz). With a modified sub reflector, the 1.8 m antennas are also used at Ka-band (20/30 GHz).

The large antennas ( $D > 1.5$  m), are only produced in a limited number, but smaller antennas are mass-produced for the consumer and professional market at Fibo-Støp, Holmestrand. At the moment they are producing three different types of antennas in large numbers (55 cm, 90 cm and 1.2 m antennas).

The 55 cm and 90 cm antennas have been produced for some years now, and they have obtained a good reputation both in Norway and in other European countries. They are shaped for high gain, and their efficiencies are higher than 80 %. The 55 cm antenna has also obtained a price for good design. Figure 3 shows this antenna. The antenna is sold through several large and small companies selling equipment for the satellite-TV receive market.

Last year, the production of a new 1.2 m antenna started. This antenna is intended for both the receive-only consumer market and for the business communication market in the 11/14 GHz band. It is shaped to have rather low sidelobes and still having high gain. Like the other antennas produced at Fibo-Støp, this antenna will be sold at a low price.

### 3 Microstrip array antennas

#### 3.1 Introduction

In 1989 Norwegian Telecom Research (NTR) performed a study of array antennas in communication systems. The study report (5) concludes that antennas for mobile satellite terminals



Figure 2 1.8 m antenna on transportable earth station



Figure 3 Fibo-støp 55 cm antenna

are one of the most promising applications for array antennas.

As a consequence of the results from this study, we started construction of antenna elements for L band (1.5 - 1.6 GHz)(6). The elements are modified square patches. As can be seen from figure 5, two of the corners of the elements are cut off. The goal is to obtain circular polarisation with only one feed point. In order to improve the axial ratio, the elements are sequentially rotated and phase shifted when used in arrays (7). This technique gives almost perfect circular polarisation in the boresight direction of the antenna, and very good circular polarisation in an angular area around the boresight. In addition, reflections to the input port cancel each other, improving the VSWR performance of the antenna.

### 3.2 INMARSAT-C

The first antenna which was developed was an antenna with higher gain for INMARSAT-C terminals. The ordinary C antenna is "nearly" omnidirectional. NTR developed a new antenna with approximately 11 dBi gain. This antenna is now being manufactured by ABB NERA, and is used in the Saturn-C Portable terminal. A short description of the performance of the C antenna is given in table 1. A photo of the antenna is shown in figure 4.



Figure 4 Antenna for a portable INMARSAT-C terminal

### 3.3 INMARSAT-M

NTR is now developing antennas for INMARSAT-M, a system which will be operational in 1993. This system will use terminals with antenna gains in the region 13-16 dBi. Array antennas with a small number of elements are a natural choice for these terminals. The small size of the antennas gives only small losses, and the antennas may be manufactured with low cost and low weight. Table 2 gives an overview of the main specifications for the INMARSAT-M system (8).

Table 3 gives the most important performance parameters for the first prototype antenna for a portable INMARSAT-M terminal. A photo of the antenna is shown in figure 5. This antenna will be used in ABB-NERA's Saturn-M Portable terminal.

NTR has also developed an experimental INMARSAT-M antenna for land mobile applications. This antenna has been used for experiments with different tracking systems, both mechanical and electronic. A photo of the prototype is shown in figure 6. The electronic system is based on digital phase shifters, making it possible to shift the antenna beam in discrete steps. This work is aimed at developing low cost antenna systems for land mobile applications. Using mechanical steering is a costly way of realizing tracking systems, while the electronic steering has the potential for reducing the cost of the outdoor unit.

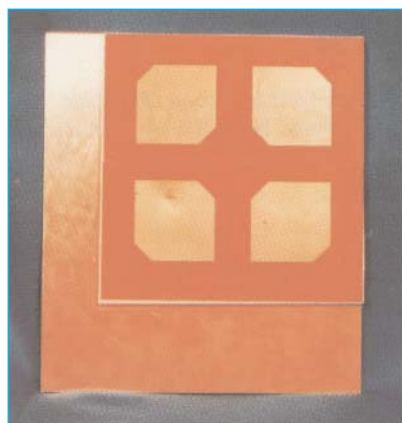


Figure 5 Antenna for a portable INMARSAT-M terminal

	Receive band	Transmit band
Axial ratio, azimuth ( $\pm 10^\circ$ )	1.8 dB	5.8 dB
Axial ratio, elevation ( $\pm 30^\circ$ )	3.5 dB	4.5 dB
Gain	$\approx 11.5$ dBi	$\approx 11.5$ dBi
Return loss	$< -17.5$ dB	$< -14.0$ dB

Table 1 Antenna for a portable INMARSAT-C terminal. Measurements

	Specifications
Minimum G/T	Landmobile -12 dBK Maritime -10 dBK
Max EIRP	Landmobile 25 dBW Maritime 27 dBW
Channel bit rate	8 kbit/s
Bandwidth	1525 - 1559 MHz (RX) 1626.5 - 1660.5 MHz (TX)
Polarization	Right hand circularly polarized, axial ratio less than 2 dB on-axis

Table 2 INMARSAT-M specifications

	Receive band	Transmit band
Axial ratio, azimuth ( $\pm 10^\circ$ )	< 0.5 dB	< 1.0 dB
Axial ratio, elevation ( $\pm 30^\circ$ )	< 0.5 dB	< 1.0 dB
Gain	$\approx 14$ dBi	$\approx 14$ dBi
Return loss	< -27 dB	< -28 dB
Side lobe level	< -17 dB	< -17 dB

Table 3 Antenna for a portable INMARSAT-M terminal. Measurements

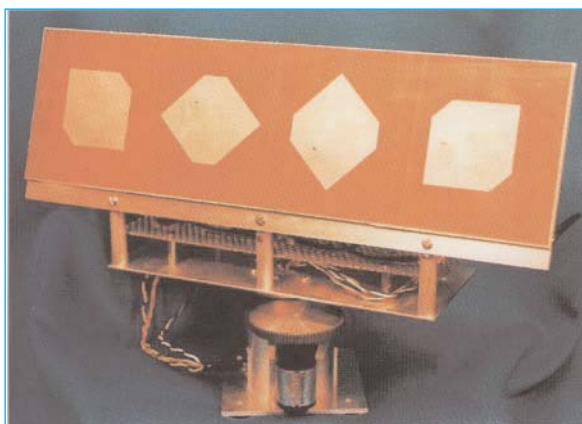


Figure 6 Experimental antenna system for land mobile INMARSAT-M terminal

## References

- 1 Kildal, P S, Pettersen, T, Lier, E, Aas, J A. Reflectors and feeds in Norway. *Telektronikk*, 2-3, 1988. Also published in: *IEEE ant. and propagat. soc. newsletter*, April 1988.
- 2 Bjøntegaard, G, Pettersen, T. A shaped offset dual reflector antenna with high gain and low side-lobe levels. ICAP81, *IEE conf. publ.* 195, 163-167, 1981.
- 3 Bjøntegaard, G, Pettersen, T. An offset dual-reflector antenna shaped from near-field measurements of the feed-horn: Theoretical calculations and measurements. *IEEE trans. ant. and propagat.*, AP-31, 973-977, Nov. 1983.
- 4 Bjøntegaard, G, Pettersen, T, Skyttemyr, S A. Design of dual shaped offset reflector antennas. *9th QMC ant. sym. proc.*, London University, 1983. Also appearing in Clarricoats and C Parini (ed.). *Recent advances in antenna theory and design*. Microwave exhibitions and publishers limited, 1989.
- 5 Nordbotten, A, Nyseth, A, Skyttemyr, S. *Array antennas in communication system*. NTR report 33, 1989. (In Norwegian).
- 6 Skyttemyr, S A. *Transmission line model for microstrip antenna*. NTR report 32, 1992. (In Norwegian).
- 7 Teshirogi, T, Tanaka, M, Chujo, W. Wideband circular polarised array antenna with sequential rotations and phase shift of elements. *Proceedings of ISAP '85*, 117-120, 1985.
- 8 *Inmarsat-M System Definition Manual*. Issue 3.0, Module 2.